

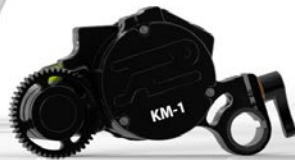

**KINORG**  
Cinemachinery design bureau

D25Ws/d, B20, KM-1, KM-2  
**USER GUIDE**



## TABLE OF CONTENTS

- **D25Wd/s controller**

MAIN OPERATION GUIDE

TECHNICAL SPECIFICATIONS

- **B20 controller**

MAIN OPERATION GUIDE

TECHNICAL SPECIFICATIONS

MOUNT TYPES

- **KM-1 Motor**

TECHNICAL SPECIFICATIONS

MAIN OPERATION GUIDE

- **KM-2 Motor**

TECHNICAL SPECIFICATIONS

MAIN OPERATION GUIDE

- **Other**

DECLARATION OF CONFIRMITY

WARRANTY

SUPPORT SERVICE

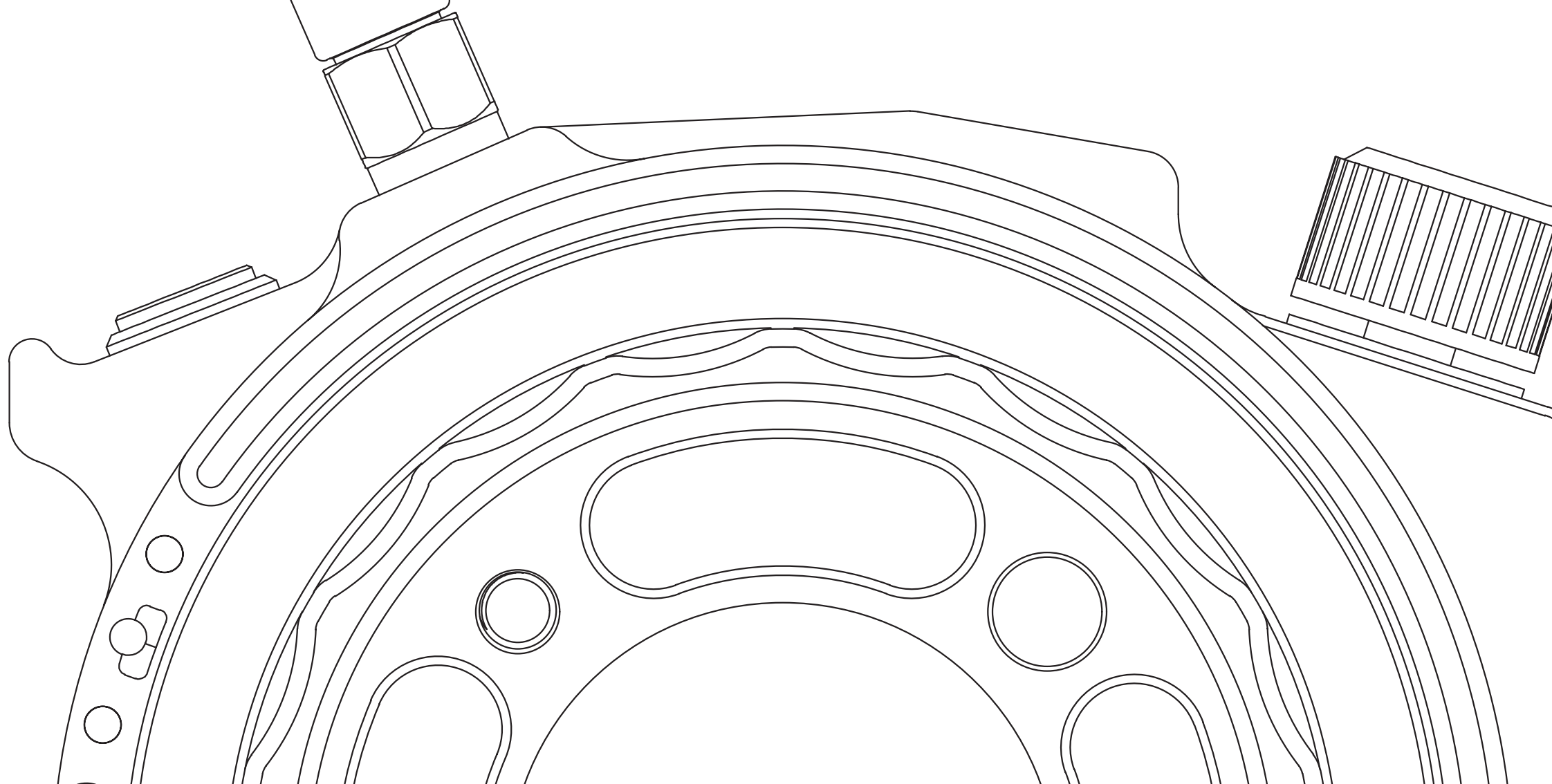

**Kinorg cinemachinery design company is introducing the newest versions of its wireless follow focus – D25Wd/s, a Dual/Single-motor follow focus, and B20 wireless follow focus applicable for gimbals and hand grips.**

The devices (hand units and motors) have durable solid-aluminum housings. Ergonomic design of the hand unit makes operating highly convenient.

The motors have on-board wireless transceiver and power stabilizer, no external controllers needed. Their torque is high enough to operate with any lenses available in film and video productions, including LOMO, ARRI Ultra Prime, etc.

There are motors of 2 types – quiet KM1 and slim KM2.

The KM2 motors are used at tight setups. They have 10% higher torque than KM1, and give higher pulling speed in case of heavy lenses.

The KM1 motors allow to record clear sound and generally are used for focus pulling.

The KM1 weight is 242 g, the KM2 weight is 248 g.

### **Main features of the Kinorg follow focus:**

- solid aluminum housing of the hand unit and motors
- high-capacity batteries (2600 mAh internal one gives up to 45 hours of activity, 1600 mAh quick-change external magnet-mounted battery adds 18 hours more)
  - 6-38V power supply support
- motors with on-board transceiver (no external controllers)
- high-torque motors, direct drive (no gear) <<<<<|||| KM2 ведь с червяком
  - ergonomically designed hand unit
  - one-click motor calibration
  - two-clicks motor pairing

We provide

**2-year free warranty**  
and fast support service



# D25Ws

Wireless follow-focus



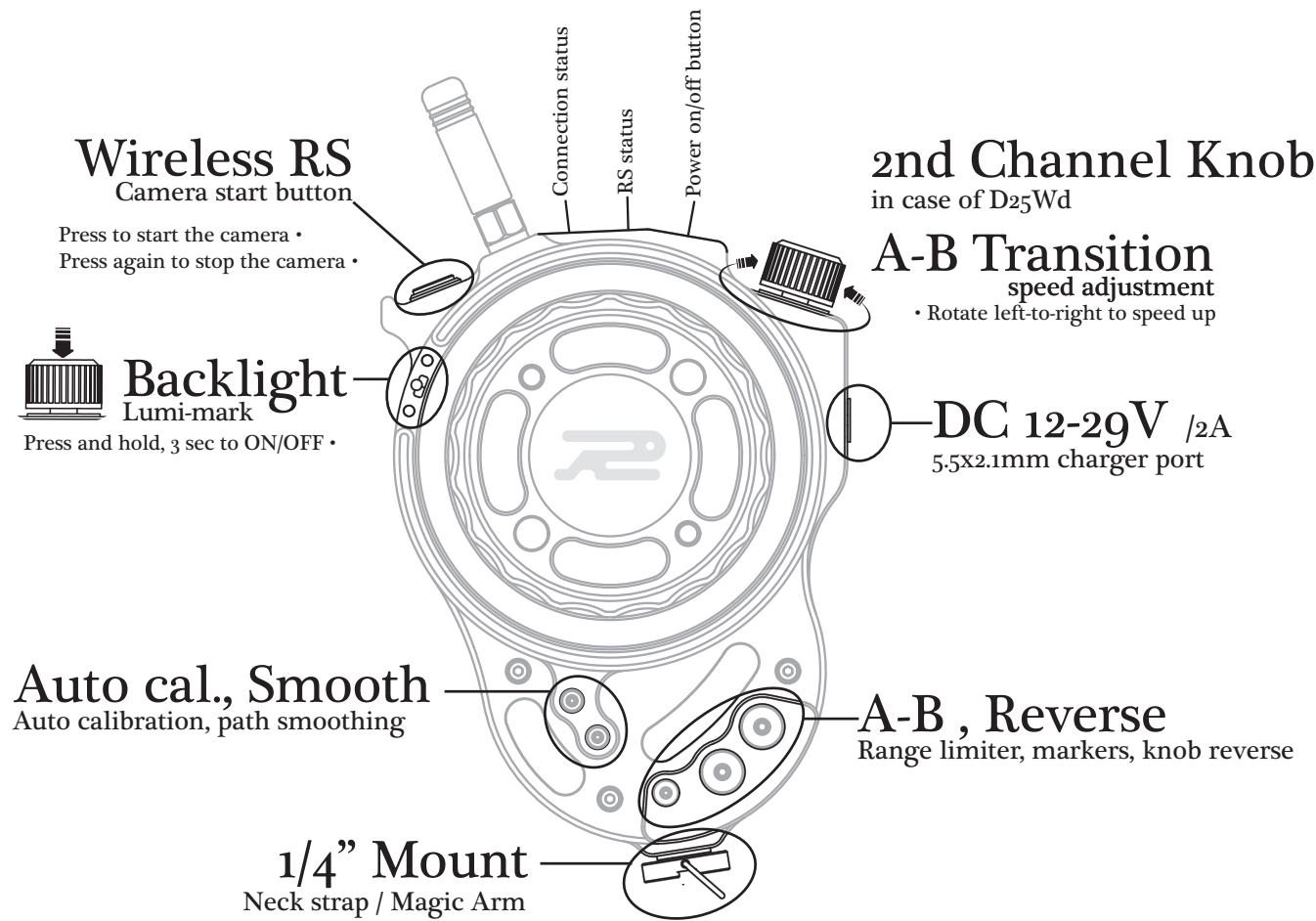



**Power ON/OFF**

- Press and hold  for 3 sec.  
The POWER LED glows green, short beep, short vibration. When the battery is low (the voltage is not enough to switch on) - the POWER and the LOW BATTERY LEDs blinks red twice.

**Pairing with the FOCUS motor (D25Ws, D25Wd models)**

- Press and hold  for 3 sec (at the back side of the hand unit)  
The CALIBRATE LED blinks. Confirm pairing by pressing a motor button (Button A or M for KM1, SET button for KM2), now the CALIBRATE LED reflects the motor calibration status

**Pairing with the IRIS/ZOOM motor (Only D25Wd model)**

- Press and hold  +  for 3 sec.
- Confirm pairing by pressing a button at the target motor  
The CALIBRATE LED blinks. After confirmation of pairing by pressing a button at the motor (Buttons A,M for KM1, SET button for KM2) the CALIBRATE LED's status depends on the motor calibration status

**Setting the range limits**

- Press and hold A+B+   
When setting the first position - double beep, A (B) LED blinks. When setting the second position - A and B LEDs glows, beep and vibration. Motor moves to the related position in the range. The range limits can be reset by recalibration.

**Setting A B digital markers and operation**

- To clear A B markers, press and hold A+B for 3 sec.
- Press and hold A or B for 3 sec.
  - Short press A or B to go to the marker's position.

**A-B Transition speed adjustment**

- Press and hold A+B+  for 5 sec.
- Then adjust the transition speed with 
- Then press and hold  for 1 sec. to finish setup 





## KM-1 Quiet motor

### Pairing confirmation:

Enter the PAIR mode of a hand unit

1. Press A or M button to confirm pairing
2. The hand unit beeps for successful pairing, KM1 antenna glows GREEN. Done.

### Manual range setting:

KM1 is paired, gear is attached to the lens ring

1. Press and hold M button for 3 sec
2. Manually rotate the lens ring to the 1st position
3. Press M button
4. Rotate the lens ring to the 2nd position
5. Press M button
5. Motor repositions according to the knob position
6. Done

- ### Automatic range calibration:
- Motor is already paired with the hand unit
1. Press A button of KM1 or Calibr. button of a hand unit
- Motor will detect the hard stops of the lens
2. Motor repositions according to the knob position
  3. Done

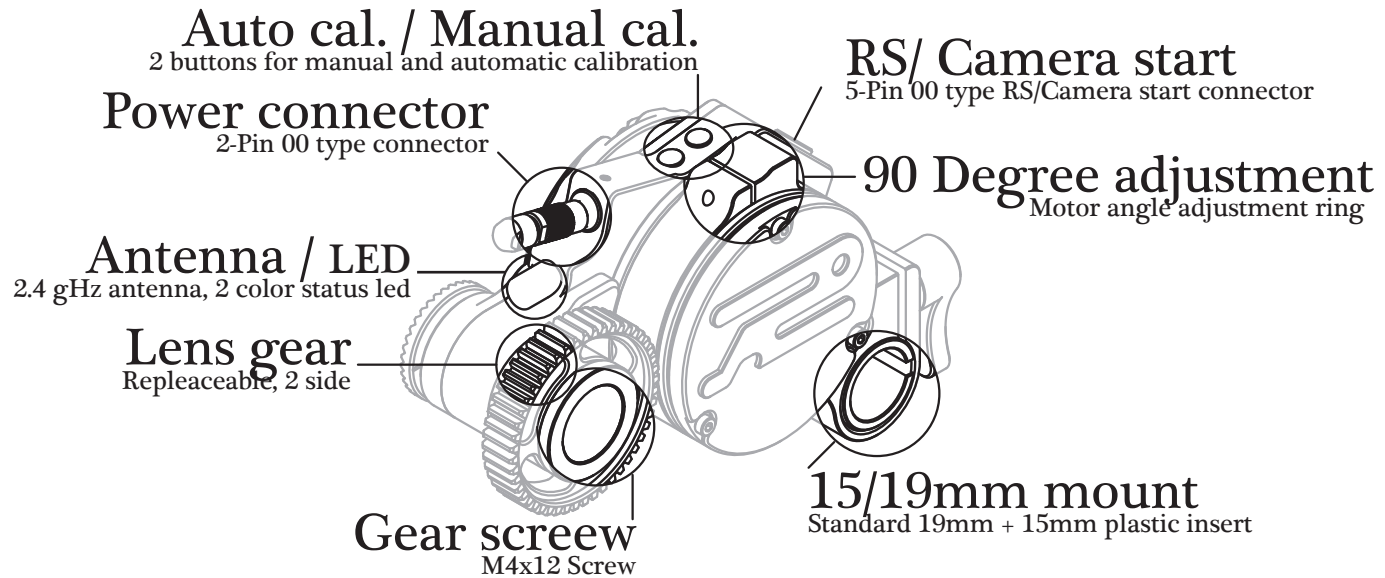

**Controller:** on-board wireless transceiver

**Rotation range:** unlimited

**Automatic calibration:** Yes

**Manual calibration on-board:** Yes

**Digital resolution:** 14-bit

**Waterproof:** Yes

**Dustproof:** Yes

**Shockproof:** Yes

**Power connector type:** 2-pin Push-Pull

**Camera start connector type:** 5-pin Push-Pull

**Consumption:** 14-24V 2.5A Max

### Camera engineer information:

KM1 is always in the “Position control” mode and has normal operating temperature from -20 to +45 °C. It withstands rain, dust, shock and humidity

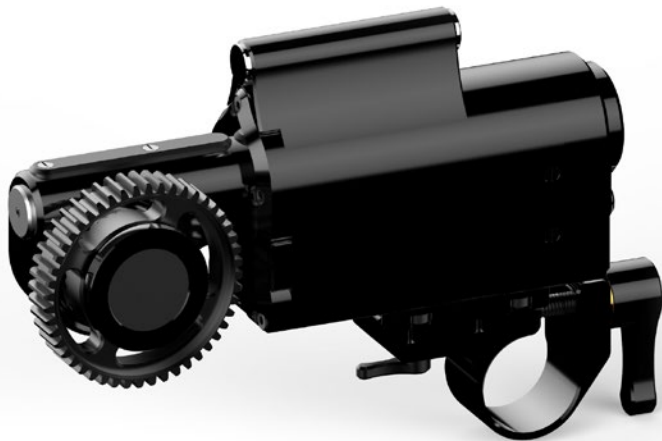

## KM-2 Standard motor

### Pairing confirmation:

Enter the PAIR mode of the hand unit

1. Press SET button to confirm pairing with the hand unit
2. The hand unit beeps for successful pairing, KM2 SET button glows GREEN. Done

### Manual range setting:

KM1 is paired with the hand unit

1. Press and hold SET (big round button) till it start blinking
2. Holding Left & Right buttons move the motor to the position 1
3. Press SET button
4. Holding Left & Right buttons move the motor to the position 2
5. Press SET button
6. Motor repositions according to the knob position, SET button glows GREEN. Done

### Automatic range setting:

Motor is already paired with the hand unit

1. Press SET button of KM2 or Calibr. button of a hand unit. Motor detects the hard stops of the lens
2. KM2 repositions according to the knob position
3. Done



## Camera start/stop

5-Pin 00 type connector

## Power connector

2-Pin 00 type connector

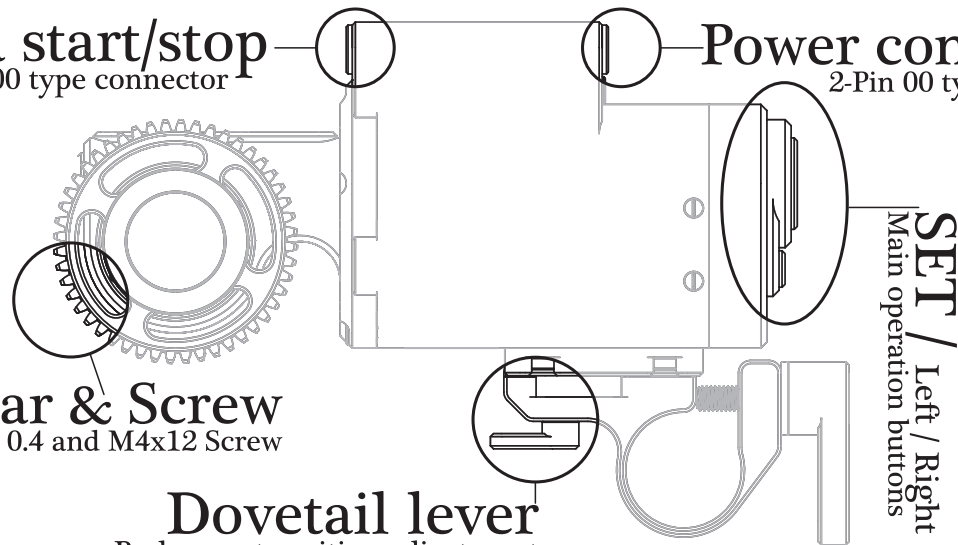

## Lens gear & Screw

m0.8, 0.6, 0.5, 0.4 and M4x12 Screw

## Dovetail lever

Rod mount position adjustment

**Controller:** on-board wireless transceiver

**Rotation range:** unlimited

**Automatic calibration:** Yes

**Manual calibration:** Yes

**Digital resolution:** 14-bit

**Waterproof:** Yes

**Dustproof:** Yes

**Shockproof:** Yes

**Power connector type:** 2-pin Push-Pull

**Camera start connector type:** 5-pin Push-Pull

**Consumption:** 12-18V 1.2A Max

### Camera engineer information:

The motor is always in the “Position control” mode and has normal operating temperature from -20 to +45 °C. It withstands rain, dust, shock and humidity

## KM1, KM2 On set

Motors fit rods of all types, 19-to-15 mm plastic insert reduces the inner diameter

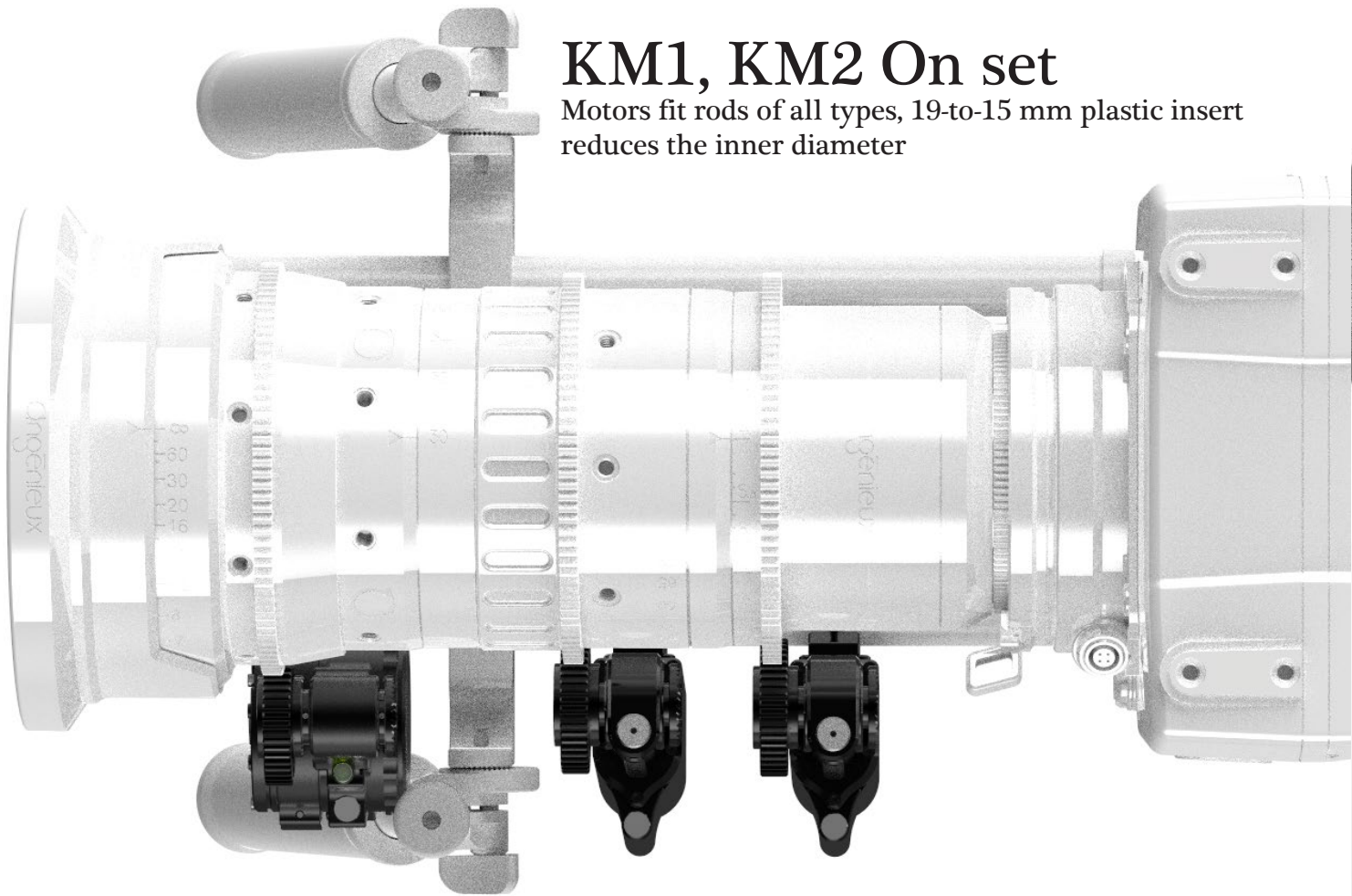



Standalone  
**Wireless controller**  
Suitable for gimbals/steady-cams/hand-grips

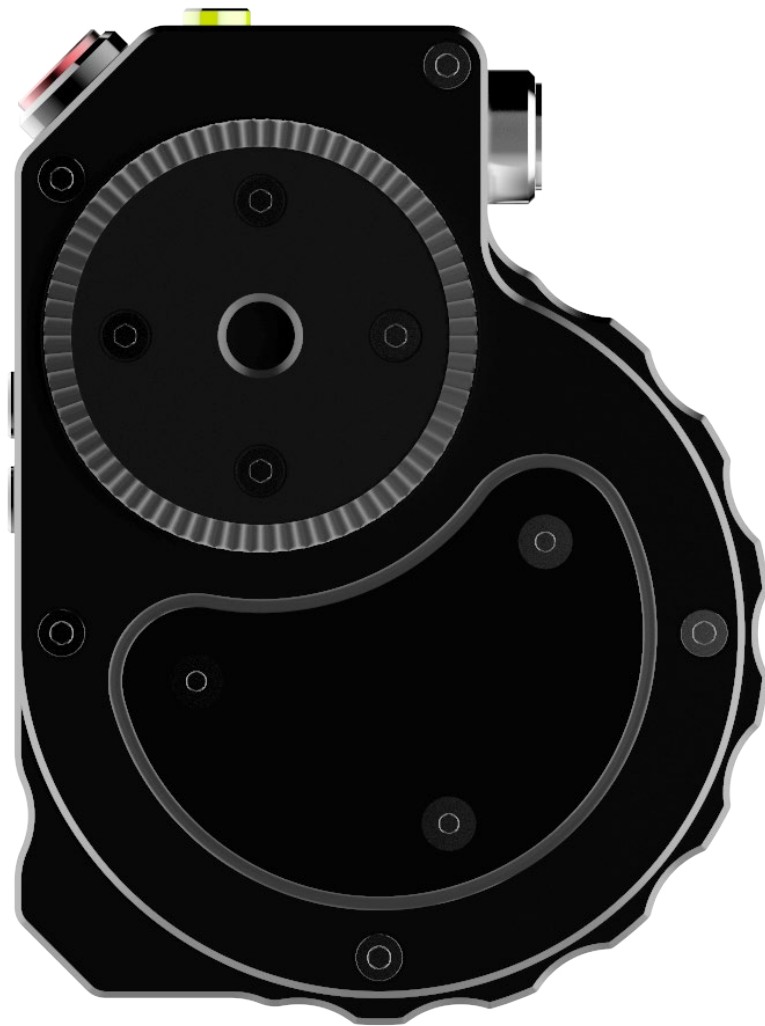



### Power ON/OFF

- Simply connect the power cable to switch on  
The POWER LED glows green

### Pairing with the motor

- Press and hold  button for 3 sec (at the front side)  
Confirm pairing by pressing a button of the motor (Button A or M for KM1, SET button for KM2)

### Automatic calibration

- Press A button  
Paired motor will detect the lens range automaticaly

### Manual calibration

- This controller has no manual calibration functionality  
Use motor's manual calibration function

### Reverse knob direction

- Press R button to reverse the knob direction

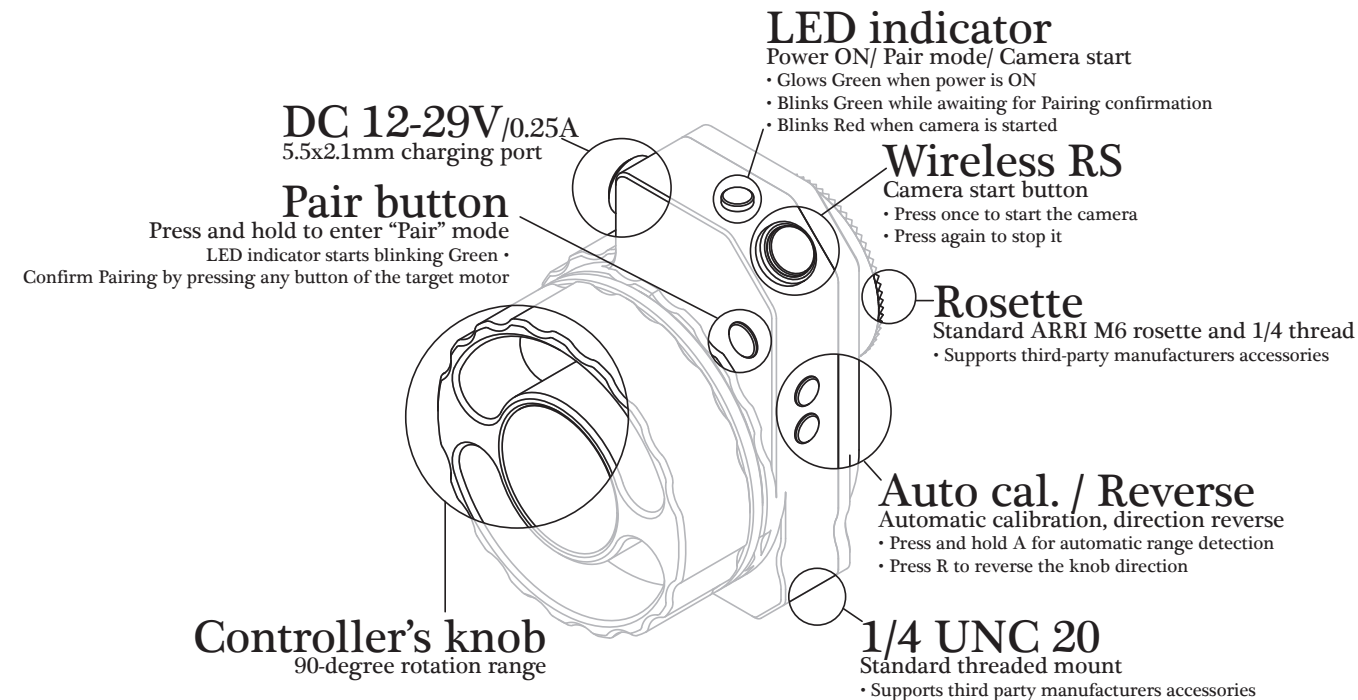

### **Camera engineer information:**

This unit can be mountet with MagicArm, Rosette, 1/4 Thread using all types of standard 3rd party accessories.

### **Specifications:**

Normal operating temperature from -10 to +45 °C.  
It withstands direct rain, dust, shock and humidity.

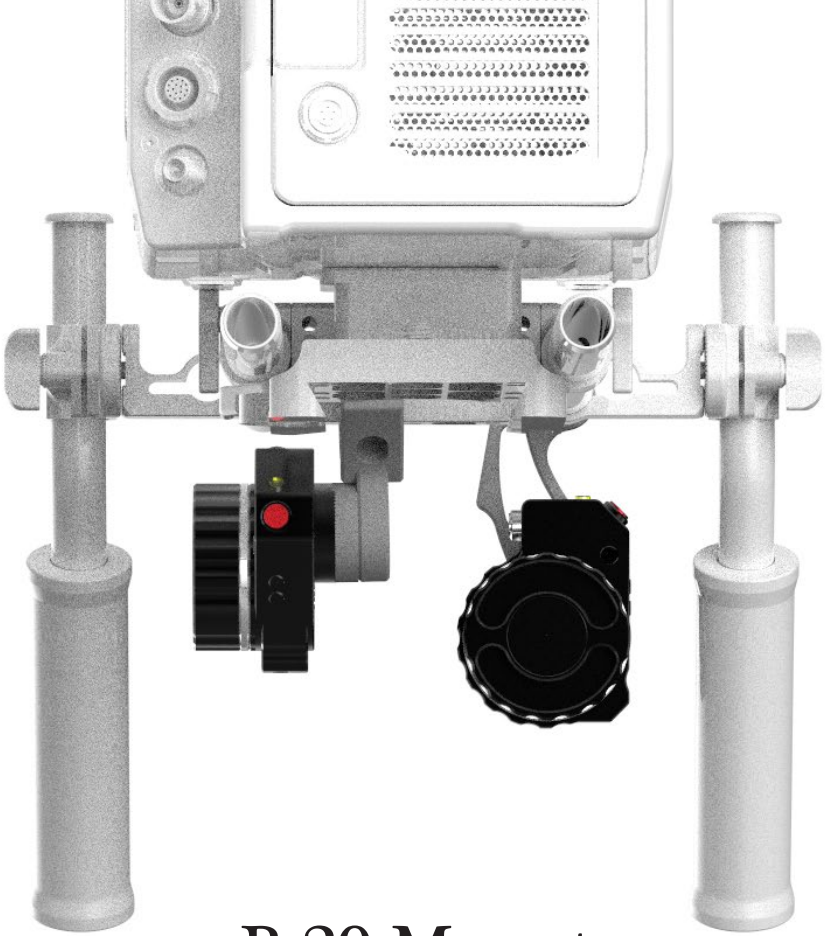

## B-20 Mount

The unit can be mounted by means of rosette or 1/4" standard thread  
Recommended mounting: rosette, magic-arm, super-clamp



# Firmware update

for motors and hand units

## D25Ws/d

The firmware update is performed through the micro-USB Interface

Find the micro-USB port behind the plastic cover at the back side of D25Ws/d

1. Download 3 files of the newest firmware from [www.kinorg.com](http://www.kinorg.com)
2. Connect D25Ws/d to your computer using a micro-USB cable (it will get detected as a flash-drive) and upload the files to the hand unit
3. Press and hold  button and wait till the hand unit powers on.

It takes few seconds longer than the standard power-on procedure

## KM1/KM2

The firmware update is performed wirelessly, D25Ws/d acts as a host

The fresh firmware files are already uploaded to the hand unit

1. Power on D25Ws/d and the target motor(s)
2. Pair the hand unit with the target motor/s  
Do not calibrate the motor/s
3. Press and hold Reverse + Calibration buttons at the front side of D25Ws/d for 10 sec  
Hand unit Smooth, Calibration, A, B led indicators start blinking. Update time can take from 10 to 60 sec
4. Restart the hand unit (power off and then power on)  
After restarting the system is ready for operation

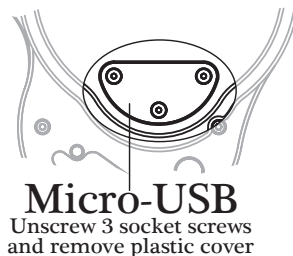

# Additional information

Declaration of confirmity/Warranty/Support Service

## Warranty regulations

Free warranty for 2 years

Except cables, connectors, batteries, antenna or brute force damages

## Support Service

Please contact your local distributor or dealer.

To solve unstandard issues contact us using the web-form on [www.kinorg.com](http://www.kinorg.com)

## Declaration of confirmity

EU DECLARATION OF CONFORMITY

We thereby declare that this declaration of conformity is issued under the sole responsibility of the manufacturer, Kinorg sp. z o.o., within the scope of EU Directive:  
radio equipment directive RED 2014/53/EU

The object of the declaration is in conformity with the relevant Union harmonized standards:  
EN 60950-1:2006+A11:2009+A1:2010+A12:2011+A2:2013 (article 3(1) point (a) 2014/53/EU)  
ETSI EN 300 328 v2.1.1:2016 (article 3(2) 2014/53/EU)  
ETSI EN 301 489-17 v3.1.1:2016 (article 3(1) point (b) 2014/53/EU)  
ETSI EN 301 489-1 v2.1.1:2016 (article 3(1) point (b) 2014/53/EU)

