

SONY®

DIGITAL CAMCORDER

MSW-970/970P

The supplied CD-ROM includes operation manuals for the MSW-970/970P Digital Camcorder (English, Japanese, French, German, Italian, Spanish and Chinese versions) in PDF format.
For more details, see "1-4 Using the CD-ROM Manual" on page 15.

Power HAD EX

MPEG IMX



Tele-File

MEMORY STICK™

OPERATION MANUAL
1st Edition (Revised 2)

English

WARNING

To reduce the risk of fire or electric shock, do not expose this apparatus to rain or moisture.

To avoid electrical shock, do not open the cabinet. Refer servicing to qualified personnel only.

For the customers in the USA

This equipment has been tested and found to comply with the limits for a Class A digital device, pursuant to Part 15 of the FCC Rules. These limits are designed to provide reasonable protection against harmful interference when the equipment is operated in a commercial environment. This equipment generates, uses, and can radiate radio frequency energy and, if not installed and used in accordance with the instruction manual, may cause harmful interference to radio communications. Operation of this equipment in a residential area is likely to cause harmful interference in which case the user will be required to correct the interference at his own expense.

You are cautioned that any changes or modifications not expressly approved in this manual could void your authority to operate this equipment.

All interface cables used to connect peripherals must be shielded in order to comply with the limits for a digital device pursuant to Subpart B of Part 15 of FCC Rules.

For the customers in the USA and Canada RECYCLING LITHIUM-ION BATTERIES

Lithium-Ion batteries are recyclable.

You can help preserve our environment by returning your used rechargeable batteries to the collection and recycling location nearest you.

For more information regarding recycling of rechargeable batteries, call toll free 1-800-822-8837, or visit <http://www.rbrbc.org/>

Caution: Do not handle damaged or leaking lithium-ion batteries.



For the State of California, USA only

Perchlorate Material - special handling may apply, See www.dtsc.ca.gov/hazardouswaste/perchlorate
Perchlorate Material : Lithium battery contains perchlorate.

For the customers in Europe

This product with the CE marking complies with the EMC Directive (89/336/EEC) issued by the Commission of the European Community.

Compliance with this directive implies conformity to the following European standards:

- EN55103-1: Electromagnetic Interference (Emission)
- EN55103-2: Electromagnetic Susceptibility (Immunity)

This product is intended for use in the following Electromagnetic Environment(s):

E1 (residential), E2 (commercial and light industrial), E3 (urban outdoors) and E4 (controlled EMC environment, ex. TV studio).

Voor de Klanten in Nederland

- Gooi de batterij niet weg maar lever deze in als klein chemisch afval (KCA).
- Dit apparaat bevat een vast ingebouwde batterij die niet vervangen hoeft te worden tijdens de levensduur van het apparaat.
- Raadpleeg uw leverancier indien de batterij toch vervangen moet worden. De batterij mag alleen vervangen worden door vakbekwaam servicepersoneel.
- Lever het apparaat aan het einde van de levensduur in voor recycling, de batterij zal dan op correcte wijze verwerkt worden.

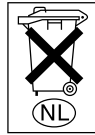

For the customers in Taiwan only



廢電池請回收

AVERTISSEMENT

Afin de réduire les risques d'incendie ou d'électrocution, ne pas exposer cet appareil à la pluie ou à l'humidité.

Afin d'écartier tout risque d'électrocution, garder le coffret fermé. Ne confier l'entretien de l'appareil qu'à un personnel qualifié.

Pour les utilisateurs aux Etats-Unis et au Canada. RECYCLAGE DES ACCUMULATEURS AUX IONS DE LITHIUM

Les accumulateurs aux ions de lithium sont recyclables. Vous pouvez contribuer à préserver l'environnement en rapportant les piles usées dans un point de collection et recyclage le plus proche.

Pour plus d'informations sur le recyclage des accumulateurs, téléphonez le numéro gratuit

1-800-822-8837 (Etats-Unis et Canada uniquement), ou visitez <http://www.rbrcl.org/>

Avertissement : Ne pas utiliser des accumulateurs aux ions de lithium qui sont endommagés ou qui fuient.



Pour les clients européens

Ce produit portant la marque CE est conforme à la Directive sur la compatibilité électromagnétique (EMC) (89/336/CEE) émise par la Commission de la Communauté européenne.

La conformité à cette directive implique la conformité aux normes européennes suivantes :

- EN55103-1 : Interférences électromagnétiques (émission)
- EN55103-2 : Sensibilité électromagnétique (immunité)

Ce produit est prévu pour être utilisé dans les environnements électromagnétiques suivants :

E1 (résidentiel), E2 (commercial et industrie légère), E3 (urbain extérieur) et E4 (environnement EMC contrôlé, ex. studio de télévision).

WARNUNG

Um die Gefahr von Bränden oder elektrischen Schlägen zu verringern, darf dieses Gerät nicht Regen oder Feuchtigkeit ausgesetzt werden.

Um einen elektrischen Schlag zu vermeiden, darf das Gehäuse nicht geöffnet werden. Überlassen Sie Wartungsarbeiten stets nur qualifiziertem Fachpersonal.

Für Kunden in Europa

Dieses Produkt besitzt die CE-Kennzeichnung und erfüllt die EMV-Richtlinie (89/336/EWG) der EG-Kommission.

Angewandte Normen:

- EN55103-1: Elektromagnetische Verträglichkeit (Störaussendung)
- EN55103-2: Elektromagnetische Verträglichkeit (Störfestigkeit),

für die folgenden elektromagnetischen Umgebungen:

E1 (Wohnbereich), E2 (kommerzieller und in beschränktem Maße industrieller Bereich), E3 (Stadtgebiet im Freien) und E4 (kontrollierter EMV-Bereich, z.B. Fernsehstudio).

Für Kunden in Deutschland

Entsorgungshinweis: Bitte werfen Sie nur entladene Batterien in die Sammelboxen beim Handel oder den Kommunen.

Entladen sind Batterien in der Regel dann, wenn das Gerät abschaltet und signalisiert „Batterie leer“ oder nach längerer Gebrauchsdauer der Batterien „nicht mehr einwandfrei funktioniert“. Um sicherzugehen, kleben Sie die Batteriepole z.B. mit einem Klebestreifen ab oder geben Sie die Batterien einzeln in einen Plastikbeutel.

ATTENZIONE

Per ridurre il rischio di incendi o scosse elettriche, non esporre questo apparato alla pioggia o all'umidità.

Per evitare scosse elettriche, non aprire l'involucro. Per l'assistenza rivolgersi unicamente a personale qualificato.

Per i clienti in Europa

Questo prodotto recante il marchio CE è conforme sia alla direttiva sulla compatibilità elettromagnetica (EMC) (89/336/CEE) emessa dalla Commissione della Comunità Europea. La conformità a queste direttive implica la conformità alle seguenti normative europee:

- EN55103-1: Interferenza elettromagnetica (Emissione)
- EN55103-2: Sensibilità ai disturbi elettromagnetici (Immunità)

Questo prodotto è destinato all'uso nei seguenti ambienti elettromagnetici:

E1 (residenziali), E2 (commerciali e industriali leggeri), E3 (esterni urbani) e E4 (ambienti EMC controllati, ad esempio studi televisivi).

ADVERTENCIA

Para reducir el riesgo de electrocución, no exponga este aparato a la lluvia ni a la humedad.

Para evitar descargas eléctricas, no abra el aparato. Solicite asistencia técnica únicamente a personal especializado.

Para clientes de los EE UU y CANADÁ

RECYCLADO DE BATERIAS DE IONES DE LITIO

Las baterías de iones de litio son reciclables.

Usted podrá ayudar a conservar el medio ambiente devolviendo las baterías usadas al punto de reciclaje más cercano.

Para más información sobre el reciclado de baterías, llame al número gratuito

1-800-822-8837, o visite <http://www.rbrc.org/>

Precaución: No utilice baterías de iones de litio dañadas o con fugas.



Para los clientes de Europa

Este producto cumple con las directivas de compatibilidad electromagnética (89/336/CEE) de la Comisión Europea.

El cumplimiento de estas directivas implica la conformidad con los siguientes estándares europeos:

- EN55103-1: Interferencia electromagnética (Emisión)
- EN55103-2: Susceptibilidad electromagnética (Inmunidad)

Este producto está ha sido diseñado para utilizarse en los entornos electromagnéticos siguientes:

E1 (zona residencial), E2 (zona comercial e industrial ligera), E3 (exteriores urbanos), y E4 (entorno con EMC controlada, p. ej., estudio de televisión).

警告

为减少火灾或电击危险，请勿让本设备受到雨淋或受潮。

为避免电击，请勿拆卸机壳。维修事宜应仅由合格维修人员进行。

Table of Contents

Chapter 1 Overview

1-1 Features	11
1-1-1 Camera Features	11
1-1-2 VTR Features	12
1-1-3 Other Features	12
1-2 Example of System Configuration	14
1-3 Precautions	15
1-4 Using the CD-ROM Manual	15
1-4-1 Preparations	15
1-4-2 Reading the CD-ROM Manual	15

Chapter 2 Locations and Functions of Parts and Controls

2-1 Power Supply	16
2-2 Accessory Attachments	17
2-3 Audio Functions	18
2-4 Shooting and Recording/Playback Functions	21
2-5 Menu Operating Section	26
2-6 Time Code System	28
2-7 Warnings and Indications	30
2-8 Warnings and Indications on the Display Panel	31
2-9 Indicators in the Viewfinder	33

Chapter 3 Recording and Playback

3-1 About Cassette	34
3-1-1 Loading and Unloading a Cassette	34
3-1-2 Preventing Accidental Erasure.....	35
3-2 Recording	36
3-2-1 Basic Procedures	36
3-2-2 Continuous Recording	37
3-2-3 Recording Essence Marks.....	38
3-2-4 Starting a Shoot with a Few Seconds of Pre-Stored Picture Data (Picture Cache Function: with MSDW-903).....	41
3-2-5 Shooting Picture at Intervals (Interval Rec Function: with MSDW-903)	43
3-2-6 Continuous Recording on Previous Cut.....	50

3-2-7 Searching for the Last Recorded Portion and Turning in Recording Pause Mode (End Search Function).....	51
3-3 Checking Recording and Playback.....	52
3-3-1 Checking the Last Two Seconds of the Recording — Recording Review.....	52
3-3-2 Checking the Recording on the Color Video Monitor — Playback in Color.....	52
3-4 Tele-File System	53
3-4-1 Recording the Recording Start Time Code onto the Memory Label.....	53
3-4-2 Recording a Tele-File Mark.....	54
3-5 Recording Video Signals from External Equipment (When Using an MSDW-904).....	55
3-6 Freezing a Picture During Playback.....	58
3-7 Setting the Stand-by off Timer During Rec-Pause	59

Chapter 4 Adjustments and Settings for Recording

4-1 Adjusting the Black Balance and the White Balance .60	60
4-1-1 Adjusting the Black Balance.....	60
4-1-2 Adjusting the White Balance	61
4-2 Setting the Electronic Shutter	63
4-2-1 Shutter Modes	63
4-2-2 Selecting the Shutter Mode and Shutter Speed	64
4-3 Changing the Reference Value for Automatic Iris Adjustment.....	67
4-4 Adjusting the Audio Level	69
4-4-1 Manually Adjusting the Audio Input Level of the AUDIO IN CH1/CH2 Connectors.....	69
4-4-2 Manually Adjusting the Audio Level of the Front Microphone	70
4-4-3 Input level of audio channels CH-3 and CH-4.....	71
4-5 Setting the Time Data	71
4-5-1 Setting the Time Code.....	71
4-5-2 Saving the Actual Time in the Time Code.....	72
4-5-3 Setting the User Bits.....	72
4-5-4 Synchronizing the Time Code.....	73

Chapter 5 Menu Displays and Detailed Settings

5-1 Menu Organization and Operation	75
5-1-1 Menu Organization.....	75

5-1-2 Basic Menu Operations.....	76
5-1-3 Editing the USER Menu	78
5-2 Status Display on the Viewfinder Screen	82
5-2-1 Layout of the Status Display on the Viewfinder Screen.	82
5-2-2 Selecting the Display Items	84
5-2-3 Display Modes and Setting Change Confirmation/ Adjustment Progress Messages	85
5-2-4 Setting the Marker Display	86
5-2-5 Setting the Viewfinder	86
5-2-6 Recording Shot Data Superimposed on the Color Bars..	87
5-2-7 Setting the Shot ID.....	88
5-2-8 Displaying the Status Confirmation Windows	89
5-2-9 Confirming the Image of the Return Video Signal in the Viewfinder	91
5-3 Adjustments and Settings from Menus	92
5-3-1 Setting Gain Values for the GAIN Selector Positions	92
5-3-2 Selecting the Output Signals.....	93
5-3-3 Setting the Color Temperature Manually	93
5-3-4 Specifying an Offset for the Auto White Balance Setting.....	94
5-3-5 Assigning Functions to Assignable Switches	95
5-3-6 Setting the Date/Time of the Internal Clock	97
5-3-7 Selecting the Lens File.....	98
5-3-8 Selecting the Aspect Ratio	98
5-3-9 Setting the CCD Scan Mode	99
5-3-10 Using UMID Data.....	101
5-4 Resetting USER Menu Settings to the Standard Set- tings	104

Chapter 6 Saving and Loading User Setting Data

6-1 Saving and Loading User Files.....	105
6-1-1 Handling the “Memory Stick”	105
6-1-2 Saving USER Menu Data (User File) to the “Memory Stick”	106
6-1-3 Loading Saved Data from a “Memory Stick”	108
6-2 Saving and Loading Scene Files	109
6-2-1 Saving a Scene File.....	109
6-2-2 Loading a Scene File.....	111
6-2-3 Resetting the Settings of the Camcorder to the Standard Settings Saved in the Reference File	113
6-3 Jumping to a File-Related Menu Page When Inserting a “Memory Stick”	113

Chapter 7 Setting Up the Camcorder

7-1 Power Supply	115
7-1-1 Using a Battery Pack.....	115
7-1-2 Avoiding Breaks in Operation Due to an Exhausted Battery.....	115
7-1-3 Using an AC Adaptor.....	116
7-1-4 Using the Anton Bauer Ultralight System	116
7-2 Adjusting the Viewfinder	117
7-2-1 Adjusting the Viewfinder Position.....	117
7-2-2 Adjusting the Viewfinder Focus and Screen.....	117
7-2-3 Detaching the Viewfinder	118
7-2-4 Detaching the Eyepiece.....	118
7-3 Mounting the Lens	119
7-4 Adjusting the Flange Focal Length	120
7-5 Audio Input System	120
7-5-1 Using the Supplied Microphone.....	120
7-5-2 Using an External Microphone	121
7-5-3 Attaching a UHF Portable Tuner (for a UHF Wireless Microphone System).....	122
7-5-4 Connecting Line Input Audio Equipment.....	124
7-6 Tripod Mounting	124
7-7 Attaching/Detaching the Shoulder Strap	125
7-8 Adjusting the Shoulder Pad Position	126
7-9 Putting on the Rain Cover (Not Supplied)	126
7-10 Connecting the Remote Control Unit	127

Chapter 8 Maintenance

8-1 Testing the Camcorder Before Shooting	129
8-1-1 Preparations for Testing	129
8-1-2 Testing the Camera	129
8-1-3 Testing the VTR.....	131
8-2 Maintenance	133
8-2-1 Cleaning the Video Heads.....	133
8-2-2 Cleaning the Viewfinder	133
8-3 Operation Warnings	134

Appendixes

Specifications	136
General.....	136

Video Camera Section	136
VTR Section	137
Recommended Additional Equipment	137
Menu List	139
OPERATION Menu	139
PAINT Menu	146
MAINTENANCE Menu	151
FILE Menu	159
DIAGNOSIS Menu	162
About a “Memory Stick”	163
Index.....	165

1-1 Features

The MSW-970/970P¹⁾ is a camcorder, in which a color video camera using $\frac{2}{3}$ -inch high-definition CCDs of a 16:9 aspect ratio and a recorder of the MPEG IMX format are combined integrally. The camera's CCDs have approximately 1,000,000 picture elements (pixels) (the number of effective pixels: approximately 500,000). Its high imaging quality is established by the combination of Power HAD²⁾ EX CCDs and advanced digital signal processing technologies. In addition to resistance to vibration, dust, and moisture of the Betacam-series camcorders, this unit has various functions that make it ideal as a tool for ENG³⁾ and EFP⁴⁾.

- 1) The MSW-970 is for the NTSC broadcast system. The MSW-970P is for the PAL broadcast system. The description given in this manual applies to both models, any differences being clearly noted in the text.
- 2) Abbreviation of "Power Hole-Accumulated Diode." "Power HAD" is a registered trademark of Sony Corporation.
- 3) ENG: Electronic News Gathering
- 4) EFP: Electronic Field Production

1-1-1 Camera Features

$\frac{2}{3}$ -inch Power HAD EX CCDs

The high sensitivity, low smear $\frac{2}{3}$ -inch Power HAD EX CCDs provide high image quality which is at the top of its class.

- The unit is switchable between a 16:9 aspect ratio wide image and 4:3 standard aspect ratio.
- You can select an interlaced scan mode or progressive scan mode (30 fps (frames per second)¹⁾ for the MSW-970, 25 fps for the MSW-970P).
- With the optional CBK-FC01 Pull Down Board installed, a 24 fps²⁾ progressive scan video can be recorded subjected to pull-down (24P mode), providing imaging quality close to that of film (MSW-970 only).

- 1) More precisely, 29.97 fps
- 2) More precisely, 23.98 fps

Camera signal processing for high quality video

- The 14-bit A/D converter provides stable high-quality images and reliability.
- The high-performance electronic shutter allows you to select extended clear scan mode (ECS¹⁾) and high vertical resolution mode (EVS²⁾), to obtain clear, high-quality video.

- 1) ECS: Extended Clear Scan
- 2) EVS: Super Enhanced Vertical Definition System

Shooting functions to cope with different shooting conditions

- A slow shutter function (up to $\frac{1}{2}$ second) is provided as a standard feature. This allows noiseless shooting under very poor lighting conditions and a variety of expressive possibilities, such as shots of moving subjects which are smoothed out by afterimages.
- Owing to the scene file function, you can easily recall sets of adjustment values from the built-in memory, to match the particular lighting conditions.
- The ATW¹⁾ function provides automatic white balance adjustment in response to changing lighting conditions.
- The TruEyeTM ²⁾ process yields distortion-free video, even with high intensity colors.
- The TURBO GAIN button enables an instantaneous boost of the video gain to the maximum 48 dB.

- 1) ATW: Auto Tracing White balance
- 2) TruEye: "TruEye" is a registered trademark of Sony Corporation.

Wide range of menu settings

The menus provide the following operations, among others:

- Status display, message, and marker display settings
- Camera adjustment settings
- Switch function assignment
- "Memory Stick" operations

You can also assign any settings to the USER menu, to create customized menus.

Saving and recalling settings in a “Memory Stick”

Using an optional “Memory Stick”¹⁾, you can save menu settings for particular shooting conditions, for recall as required.

1) “Memory Stick” is a trademark of Sony Corporation.

High-functionality viewfinder

The 2-inch monochrome viewfinder allows accurate focusing.

The switch settings, automatic black balance and white balance items, status, warnings and so on appear on the viewfinder screen.

Remote control connectors

By connecting an optional RM-B150/B750 or similar remote control unit, you can control the camera settings of this unit externally.

1-1-2 VTR Features

MPEG IMX format

- Use of the MPEG IMX format allows high-performance digital recording and playback, as well as compatibility with the XDCAM IMX recording format of the Sony’s professional-use optical disc devices.
- The same cassette size (S size) as that of the Digital BETACAM can be used to achieve a long recording time of approximately 60 minutes for the MSW-970 and 71 minutes for the MSW-970P.

Metadata for easier and more comfortable operation

- It is possible to record recording-start markers and good-shot markers on the tape while shooting, and search automatically for required cuts when editing.
- Compatible with the Tele-File¹⁾ Memory Label system. Upon your pressing the button to which the Tele-File Mark function has been assigned while recording, the time code valid when you pressed the button is recorded on the MLB-1M-100 memory label (not supplied) attached to the cassette. This is very helpful for management of cassette tapes and to improve the efficiency of tape editing.

1) Tele-File: The Tele-File system is a non-contact data reading/writing system. It allows a variety of data to be stored on a 1/2-inch tape label with a non-contact IC memory.

Time Code operations inevitable in broadcasting

- LTC¹⁾ and VITC²⁾ recording and LTC playback can be performed.
- The built-in time code generator can be synchronized with an external generator.
- A lithium battery is the back-up power supply for the built-in time code generator enabling the time code to be held for approximately 5 years without being charged (with the camcorder power supply).
- The time code can be displayed in the LCD window screen even when the power is off. The automatic power shut-off function allows you to set the time when the time code display disappears.

1) LTC: Longitudinal Time Code

2) VITC: Vertical Interval Time Code

Audio functions

- A slot-in UHF portable tuner WRR-855A/855B (not supplied) can be attached.
- Four channels of 20-bit digital audio can be recorded, as well as four channels of 16-bit digital audio. (16-bit digital is the factory setting.)
- When an audio cable is connected to the AUDIO IN CH-1/CH-2 connectors (XLR 3-pin), the audio signals input to the XLR 3-pin connectors are recorded regardless of the AUDIO IN switch setting. This function is called the XLR connection automatic detection function.
- The AUDIO OUT connector (XLR 5-pin) allows the camcorder to output signals as stereo audio.

Other VTR functions

- Recording continuity from the very next frame is ensured.
- It is possible to automatically rewind and review the last 2 seconds of the recording on the tape for a quick check immediately after shooting.
- A 4-times-normal speed search function provides quick positioning of the tape.
- The camcorder searches for the most recently recorded cut and records the new cut over it. This function is called the RE-TAKE function.
- The camcorder searches for the point most recently recorded on the tape and automatically switches to paused recording mode (REC pause). This function is called the End Search function.

1-1-3 Other Features

Proper balancing design

A new shoulder-pad system that enables position adjustment in the front-to-rear direction with no need to use a tool ensures proper balance when using the unit.

Instant operation assignable switches

Function-assignable switches are provided on the side panel. Assigning the functions most useful to you, by selecting them on the menu pages, will create a smooth shooting environment.

Function extension interface and optional boards

- An extension connector can be attached to the battery attachment on the rear panel, to allow various camera adapters to be fitted.
- Use of the following optional boards permits you to expand the functions.

MSDW-903 Picture Cache Board:

Installing the board allows the camcorder to record up to several seconds of the picture before the REC button is pressed (Picture Cache Function) and to shoot pictures at intervals (Interval Rec).

MSDW-904 Analog Composite Input Board:

Installing the board allows the camcorder to record an analog composite signal from external equipment connected to the GENLOCK IN connector.

CBK-FC01 Pull Down (24P) Board (for the MSW-970 only):

With the board installed, a 24 fps progressive scan video can be recorded subjected to 2-3 pull-down.

CBK-SD01 SDI Output Board:

Installing the board enables SDI signal output from the VIDEO OUT connectors.

1-2 Example of System Configuration

The diagram below shows a typical configuration of the camcorder for ENG and EFP.

For more information about the fittings, connections, or use of additional equipment and accessories, see “Chapter 7 Setting Up the Camcorder” as well as the operation manuals for the connected equipment.

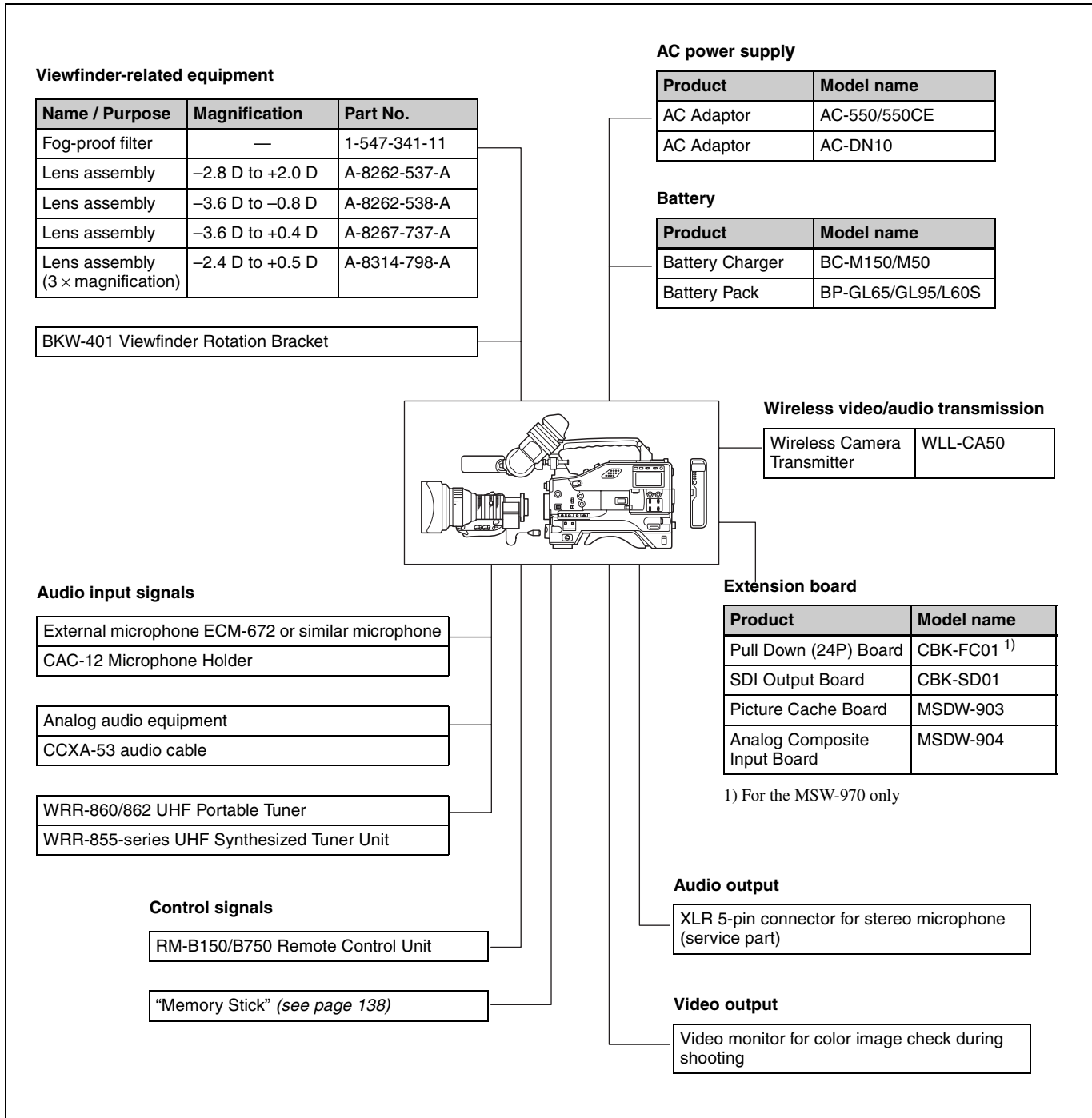

1-3 Precautions

Use and Storage

Do not subject the unit to severe shocks

The internal mechanism may be damaged or the body warped.

After use

Always turn off the power.

Before storing the unit for a long period

Remove the battery pack.

Use and storage locations

Store in a level, ventilated place. Avoid using or storing the unit in the following places.

- Places subject to temperature extremes
- Very damp places
- Places subject to severe vibration
- Near strong magnetic fields
- In direct sunlight or close to heaters for extended periods

To prevent electromagnetic interference from portable communications devices

The use of portable telephones and other communications devices near this unit can result in malfunctions and interference with audio and video signals.

It is recommended that the portable communications devices near this unit be powered off.

Note on laser beams

Laser beams may damage the CCDs. If you shoot a scene that includes a laser beam, be careful not to let the laser beam be directed into the lens of the camera.

Use at a high temperature

If the unit is used at a high temperature, white flecks may appear on the screen.

1-4 Using the CD-ROM Manual

The supplied CD-ROM includes versions of the Operation Manual for the MSW-970/970P in English, Japanese, French, German, Italian, Spanish, and Chinese in PDF format.

1-4-1 Preparations

The following program must be installed on your computer in order to read the operation manuals contained on the CD-ROM.

- Adobe Reader Version 6.0 or higher

Memo

If Adobe Reader is not installed, you can download it from the following URL:

<http://www.adobe.com/>

Adobe and Adobe Reader are trademarks of Adobe Systems Incorporated in the United States and/or other countries.

1-4-2 Reading the CD-ROM Manual

To read the operation manual contained on the CD-ROM, do the following.

- 1 Insert the CD-ROM in your CD-ROM drive.

A cover page appears automatically in your browser. If it does not appear automatically in the browser, double-click on the index.htm file on the CD-ROM.

- 2 Select and click on the operation manual that you want to read.

This opens the PDF file of the operation manual.

Memo

The files may not be displayed properly, depending on the version of Adobe Reader. In such a case, install the latest version you can download from the URL mentioned in “1-4-1 Preparations” above.

Note

If you have lost or damaged the CD-ROM, you can purchase a new one to replace it. Contact your Sony service representative.

2-1 Power Supply

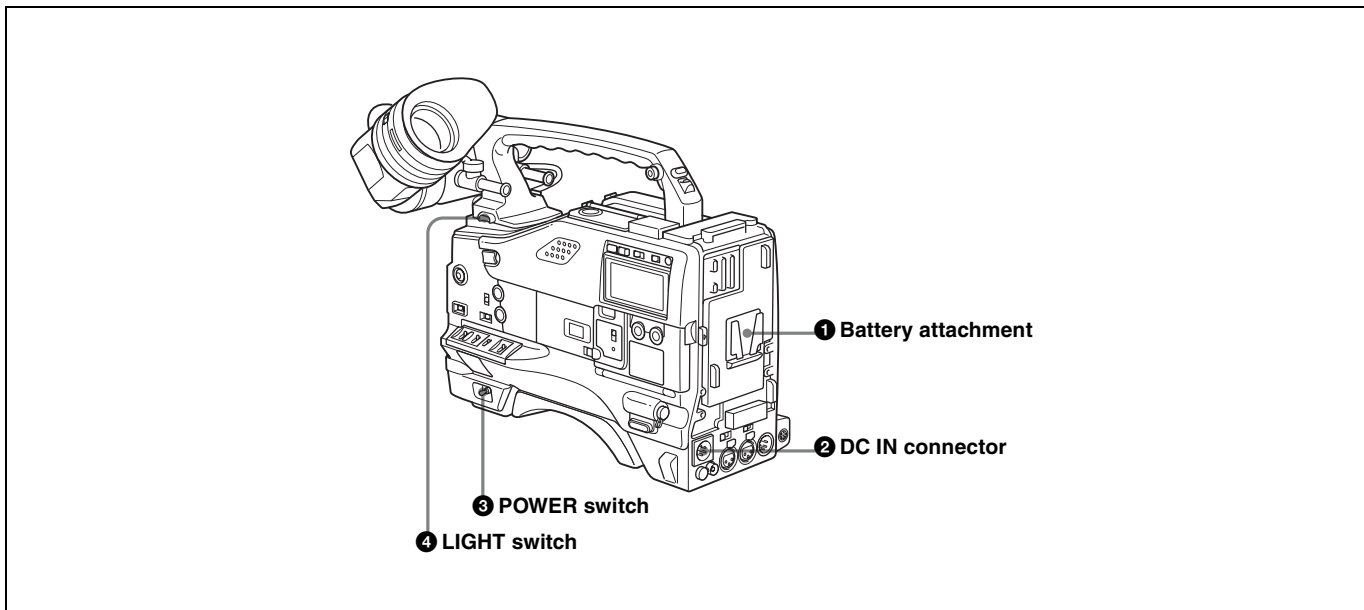

1 Battery attachment

Attach a battery pack, BP-GL65, BP-GL95, or BP-L60S. Furthermore, by attaching an AC-DN10 AC Adaptor, you can operate the camcorder from AC power.

2 DC IN connector (XLR type, 4-pin, male)

To operate the camcorder using an AC power supply, connect an AC-550/550CE AC Adaptor with the DC output cable supplied with the adaptor. To use an external battery, connect its DC output cable to the DC IN connector.

3 POWER switch

This switch turns the main power supply on and off.

4 LIGHT switch

This determines how a video light connected to the LIGHT connector is turned on and off.

AUTO: When the switch on the video light is in the on position, putting the camcorder in recording mode turns the video light on automatically. When using the

auto interval recording mode, the video light is automatically turned on immediately before recording starts.

MANUAL: You can turn the video light on or off manually, using its own switch.

2-2 Accessory Attachments

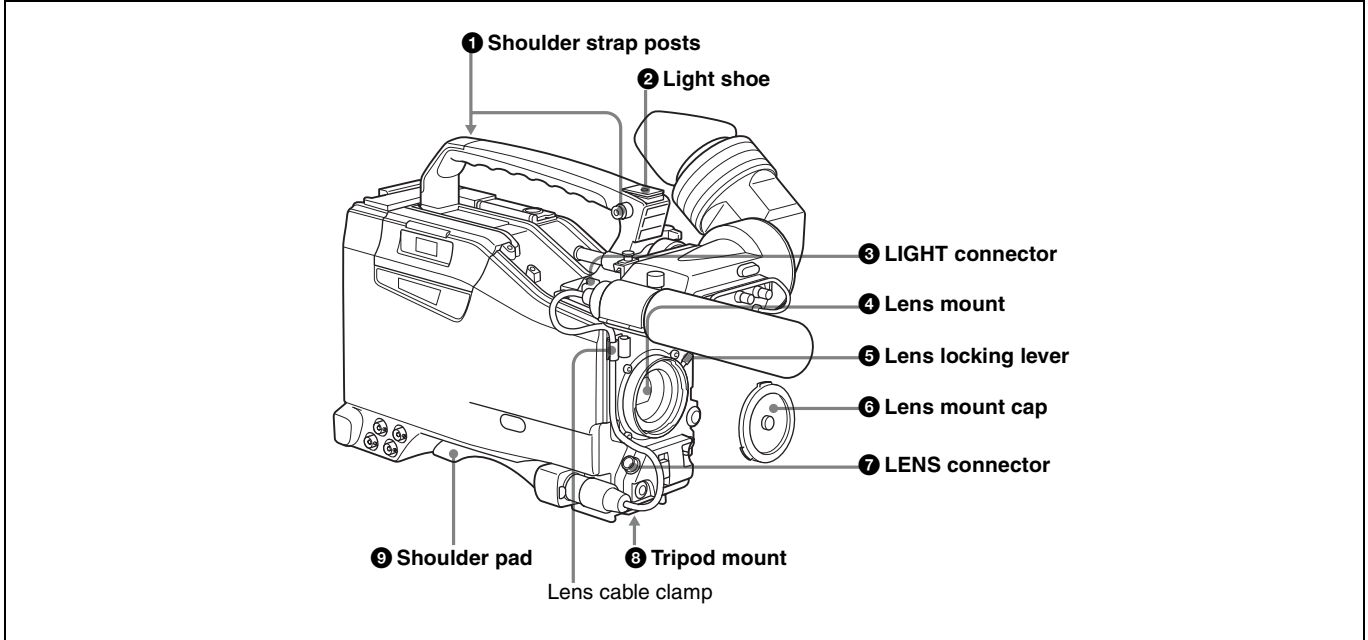

1 Shoulder strap posts

Attach the supplied shoulder strap to these posts.

For details, see “7-7 Attaching/Detaching the Shoulder Strap” on page 125.

2 Light shoe

Attach an optional accessory such as a video light to this shoe.

3 LIGHT connector (2-pin, female)

Connect the cable of an Anton Bauer Ultralight System attached to the light shoe. The system operates with lights powered by 12 V, with a maximum power consumption of 50 W.

4 Lens mount (special bayonet mount)

Use this for mounting the lens.

5 Lens locking lever

After inserting the lens in the lens mount, rotate the lens mount ring with this lever to lock the lens in position.

6 Lens mount cap

Remove this cap by pushing up the lens locking lever. When no lens is mounted, keep this cap fitted for protection from dust.

7 LENS connector (12-pin)

Fit the lens cable to this connector. Contact your Sony representative for more information about the lens you can use.

8 Tripod mount

When using the camcorder on a tripod, attach the tripod adaptor (optional).

9 Shoulder pad

You can move the shoulder pad forwards or backwards by raising up the shoulder pad locking lever. Do this to ensure the best balance when shooting with the camcorder on your shoulder.

For details, see “7-8 Adjusting the Shoulder Pad Position” on page 126.

2-3 Audio Functions

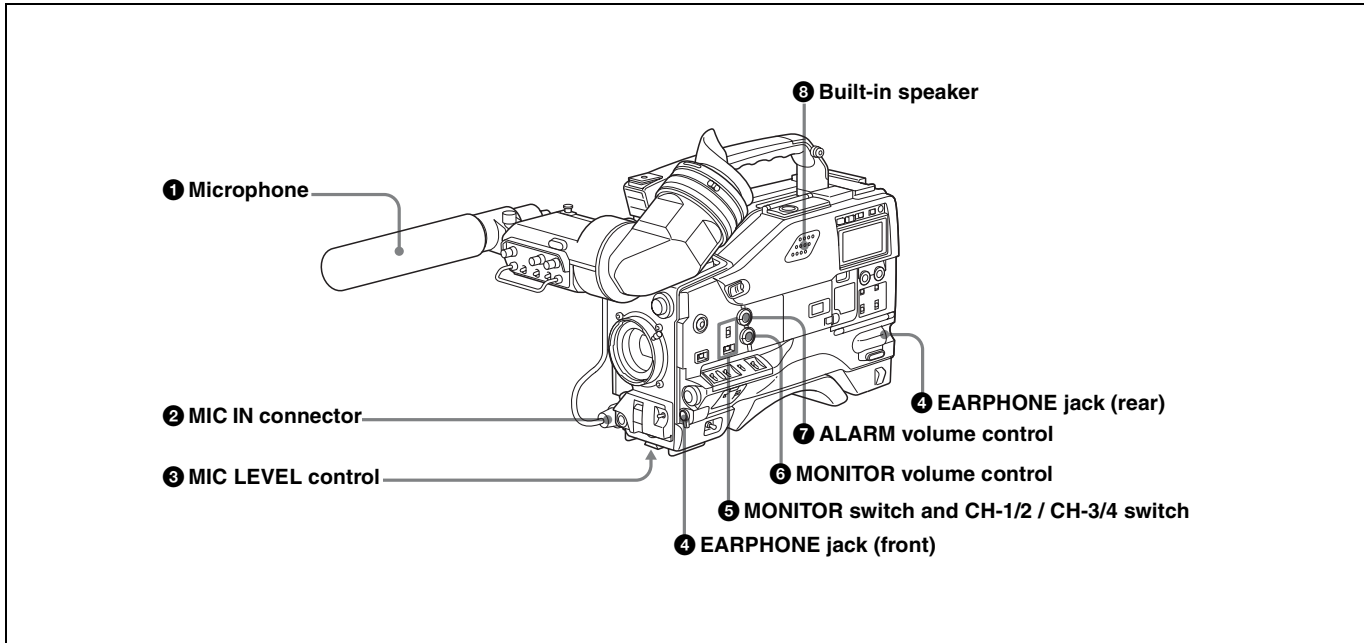

Audio functions (1)

1 Microphone

This is a super-cardioid directional monaural microphone with an external power supply (+48 V) system.

2 MIC IN (microphone input) connector (XLR type, 3-pin, female)

Connect the supplied microphone to this connector. A microphone other than the supplied one may also be connected as long as it can operate with the power (+48 V) supplied from this connector.

By fitting a 5-pin connector (service part number: A-1053-453-A), you can also use a stereo microphone.

3 MIC (microphone) LEVEL control

This control adjusts the audio level of the microphone connected to the MIC IN connector.

4 EARPHONE jacks (minijacks)

You can monitor the E-E sound ¹⁾ during recording and playback sound during playback. Plugging an earphone into the jack automatically cuts off the built-in speaker. When an alarm is indicated, you can hear the alarm sound through the earphone.

1) E-E: Abbreviation of "Electric-to-Electric." In E-E mode, video and audio signals input to the camcorder are output after passing through internal electric circuits only. This can be used to check input signals.

5 MONITOR switch and CH-1/2 / CH-3/4 switch

These switches together determine the channel selection for audio monitor output.

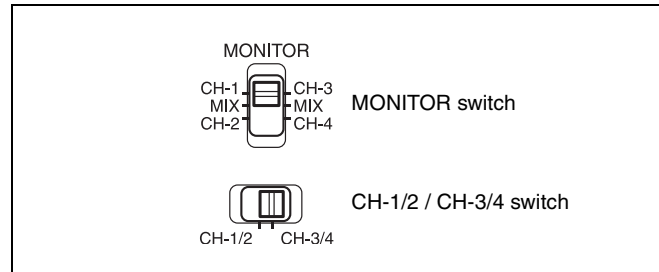

MONITOR switch and CH-1/2 / CH-3/4 switch

CH-1/2 / CH-3/4 switch:

This determines the pair of audio channels selected with the MONITOR switch.

CH-1/2 position: channels 1 and 2

CH-3/4 position: channels 3 and 4

The signals output from the AUDIO OUT connector and EARPHONE jacks and the audio level meter in the display window also depend on the setting of this switch.

MONITOR switch:

This selects the audio monitor channels output to the earphone or speaker, depending on the setting of the CH-1/2 / CH-3/4 switch.

CH-1/2/CH-3/4 switch position	MONITOR switch position	Audio output
CH-1/2	CH-1	Audio channel 1
	MIX	Mix sound of channels 1 and 2
	CH-2	Audio channel 2
CH-3/4	CH-3	Audio channel 3
	MIX	Mix sound of channels 3 and 4
	CH-4	Audio channel 4

6 MONITOR volume control

This control adjusts the speaker or earphone volume for sounds other than the alarm sound. At the minimum position, no sound can be heard.

7 ALARM volume control

This control adjusts the speaker or earphone alarm volume. At the minimum position, no sound can be heard.

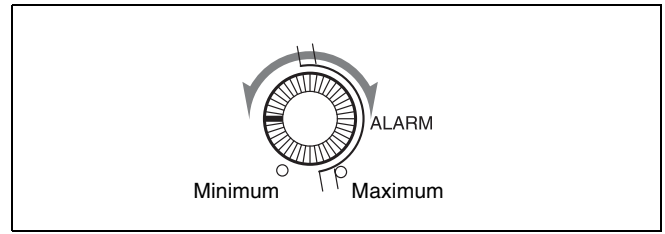

ALARM volume control

8 Built-in speaker

The speaker can be used to monitor E-E sound during recording, and playback sound during playback. The speaker also sounds alarms to reinforce visual warnings. If you connect an earphone to the EARPHONE jack, the speaker is automatically muted.

See “8-3 Operation Warnings” on page 134 for information about alarms.

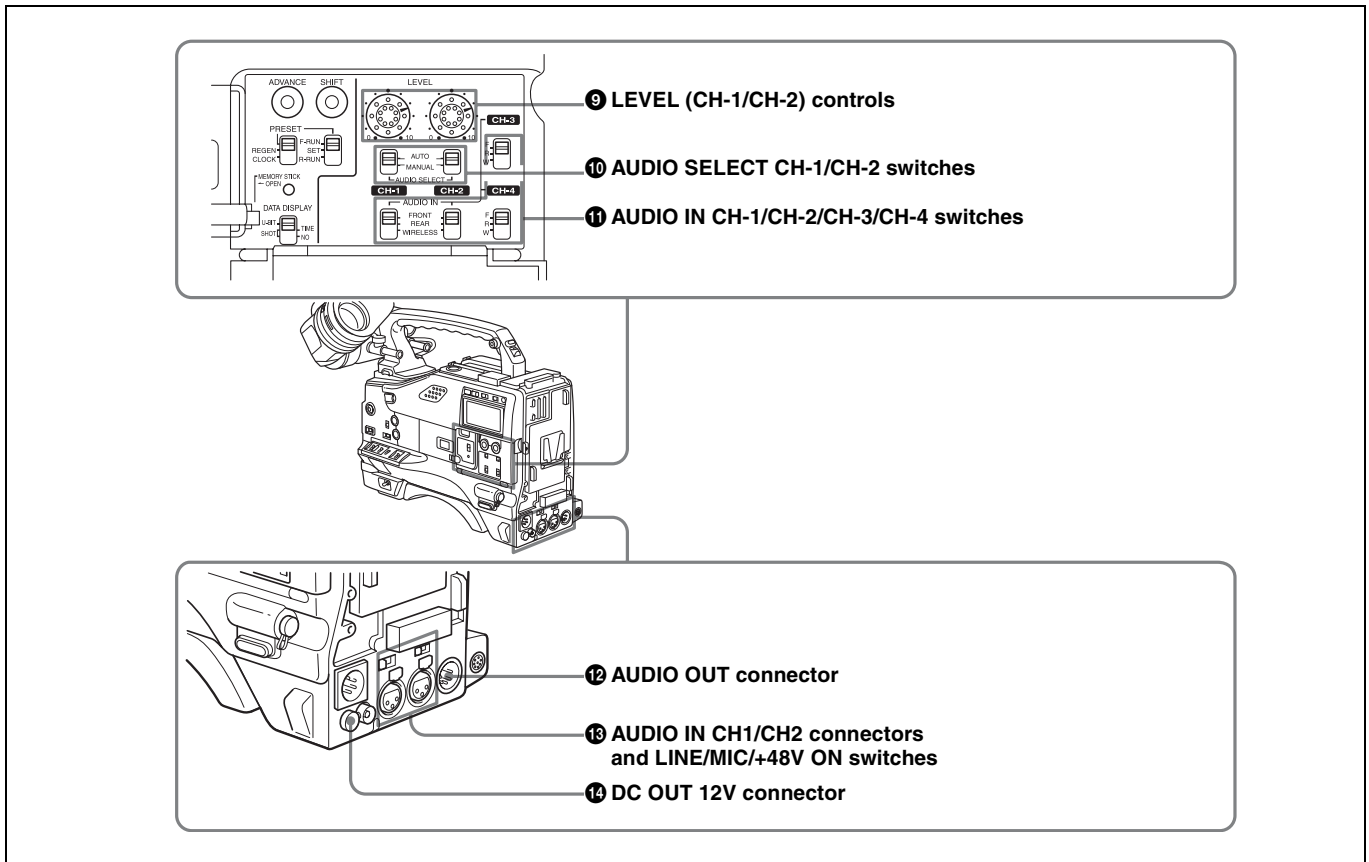

Audio functions (2)

9 LEVEL (CH-1/CH-2) (audio channel-1 and channel-2 recording level) controls

These controls adjust the audio levels of channels 1 and 2 when the AUDIO SELECT switches are set to MANUAL.

10 AUDIO SELECT CH-1/CH-2 (audio channel-1 and channel-2 adjustment method selection) switches

These switches select the audio level adjustment method for each of audio channels 1 and 2.

AUTO: Select this setting for automatic adjustment.

MANUAL: Select this setting for manual adjustment.

11 AUDIO IN CH-1/CH-2/CH-3/CH-4 (audio input selection) switches

CH-1/CH-2 switches

These switches select the audio input signals to be recorded on audio channels 1 and 2.

FRONT: The input signal source is the microphone connected to the MIC IN connector.

REAR: The input signal source is the audio equipment connected to the AUDIO IN CH1/CH2 connectors.

WIRELESS: The input signal source is a WRR-855A/855B UHF Synthesized Tuner Unit (option).

CH-3/CH-4 switches

These switches select the audio input signals to be recorded on audio channels 3 and 4.

F (front): The input signal source is the microphone connected to the MIC IN connector.

R (rear): The input signal source is the audio equipment connected to the AUDIO IN CH1/CH2 connectors.

W (wireless): The input signal source is a WRR-855A/855B UHF Synthesized Tuner Unit (not supplied).

12 AUDIO OUT (audio output) connector (XLR type, 5-pin, male)

This connector outputs the audio signals recorded on audio channels 1 and 2 or audio channels 3 and 4.

The MONITOR CH-1/2 / CH-3/4 switches allow you to select the audio signal to be monitored.

13 AUDIO IN CH1/CH2 (audio channel-1 and channel-2 input) connectors (XLR type, 3-pin, female) and LINE/MIC/+48 V ON (line input/microphone input/external power supply +48V ON) switches

These are audio input connectors for channels 1 and 2 to which you can connect audio equipment or a microphone. The LINE/MIC/+48V ON switches select the audio source of the audio input signals connected to each of these connectors.

LINE: Line input audio equipment

MIC: Microphone with an internal power supply

+48V ON: Microphone with an external power supply system

14 DC OUT 12 V (DC power output) connector (4-pin, female)

This connector supplies power for a WRR-860A/862A/862B UHF Portable Tuner (option). Do not connect any equipment other than the UHF portable tuner.

2-4 Shooting and Recording/Playback Functions

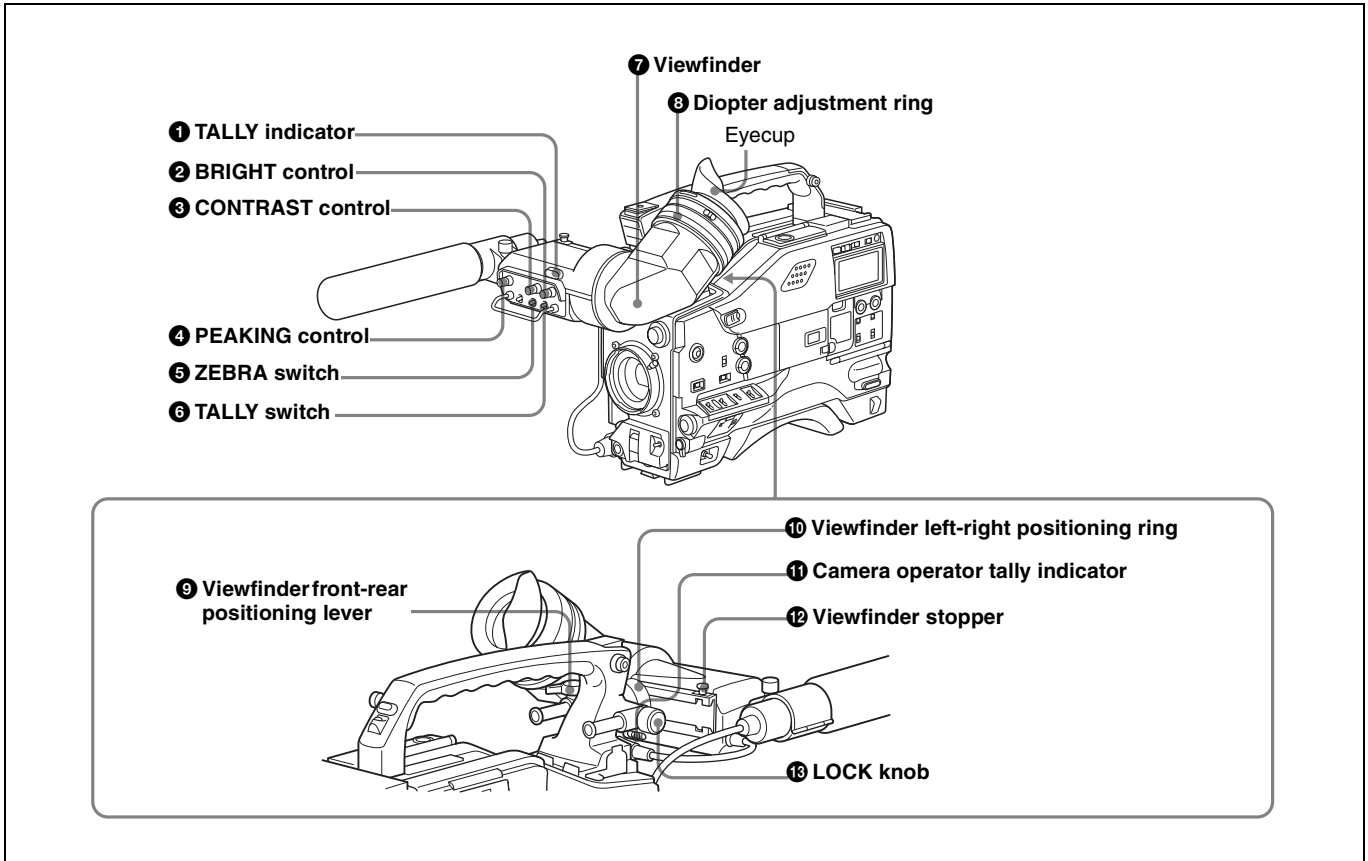

Shooting and recording/playback functions (1)

1 TALLY indicator

Setting the TALLY switch to HIGH or LOW enables this indicator. The indicator lights during recording on the VTR. Like the REC indicator in the viewfinder, it flashes to indicate a problem. You can set the indicator brightness with the TALLY switch.

2 BRIGHT (brightness) control

This control adjusts the picture brightness on the viewfinder screen. It has no effect on the camera output signal.

3 CONTRAST control

This control adjusts the picture contrast on the viewfinder screen. It has no effect on the camera output signal.

4 PEAKING control

This control adjusts the sharpness of the picture on the viewfinder screen to make focusing easier. It has no effect on the camera output signal.

5 ZEBRA switch

This switch controls the zebra pattern¹⁾ on the viewfinder screen.

ON: The zebra pattern is displayed and stays.

OFF: No zebra pattern is displayed.

MOMENT: The zebra pattern is displayed and stays for 5 to 6 seconds.

The zebra pattern is factory set to indicate picture areas where the video level is approximately 70%. You can use the setup menu to change the setting so that areas where the video level is 100% and above are also displayed at the same time.

1) The zebra pattern aids in manual iris adjustment by indicating areas of the picture where the video level is approximately 70% and 100% and above.

For information about how to change the zebra pattern setting in the setup menu, see “5-2-5 Setting the Viewfinder” on page 86.

6 TALLY switch

This switch controls the TALLY indicator, setting its brightness (HIGH or LOW) or turning it off.

HIGH: The TALLY indicator brightness is high.

OFF: The TALLY indicator is disabled.

LOW: The TALLY indicator brightness is low.

7 Viewfinder

The viewfinder lets you view the image in black and white while shooting, recording or playing back. It also displays various warnings and messages related to the settings or operating conditions of the camcorder, a zebra pattern, safety zone marker ¹⁾, and center marker ²⁾.

- 1) The safety zone marker is a rectangle indicating the effective picture area.
2) The center marker indicates the center of the picture with a crosshair.

For details, see “5-2-4 Setting the Marker Display” on page 86.

8 Diopter adjustment ring

Use this ring to adjust the viewfinder image for your vision.

9 Viewfinder front-rear positioning lever

To adjust the viewfinder position in the front-rear direction, loosen this lever and the LOCK knob. After adjustment, retighten this lever and the LOCK knob.

10 Viewfinder left-right positioning ring

Loosen this ring to move the viewfinder sideways.

11 Camera operator tally indicator

This indicator lights while the camcorder is recording. Slide the window open when you shoot with your eye away from the viewfinder. This indicator flashes when the battery level is running low or the disc is almost full.

12 Viewfinder stopper

Pull up this stopper to detach the viewfinder from the camera.

13 LOCK knob

To adjust the viewfinder position in the front-rear direction, loosen this knob and the viewfinder front-rear positioning lever. After adjustment, retighten this knob and the viewfinder front-rear positioning lever.

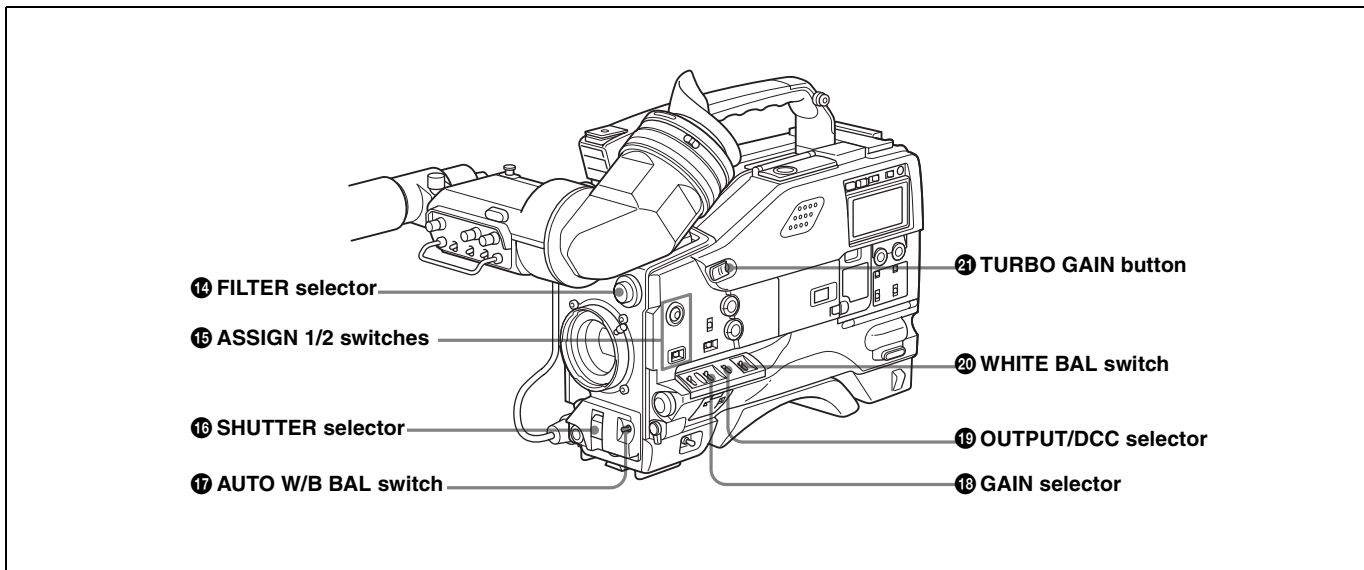

Shooting and recording/playback functions (2)

14 FILTER selector

Use this selector to select the most appropriate filter to match the light source illuminating the subject. When this selector is used with the display mode set to 3, the new setting appears on the viewfinder screen for about 3 seconds. (e.g.: ND: 1, CC: B)

The relationships between the selector settings and filter selections as well as examples of filters for different shooting conditions are as follows:

FILTER selector (outer knob) setting	CC filter selection
A	Cross filter ¹⁾
B	3200K
C	4300K
D	6300K

1) A type of special effect filter, which generates a cross of light on a highlighted portion.

FILTER selector (inner knob) setting	ND filter selection
1	Clear
2	¹ / ₄ ND
3	¹ / ₁₆ ND
4	¹ / ₆₄ ND

Shooting condition	CC filter	ND filter
Sunrise and sunset; inside studio	B (3200K)	1 (clear)
Clear skies	C (4300K) or D (6300K)	2 (1/4 ND) or 3 (1/16 ND)
Cloudy or raining	D (6300K)	1 (clear) or 2 (1/4 ND)
Very bright conditions such as snow, at high altitudes, or at the seashore	C (4300K) or D (6300K)	3 (1/16 ND) or 4 (1/64 ND)

15 ASSIGN 1/2 switches

You can assign the desired functions to each of the ASSIGN 1 switch (push button) and ASSIGN 2 switch (sliding) on the FUNCTION 1 page of the USER menu.

For details, see “5-3-5 Assigning Functions to Assignable Switches” on page 95.

16 SHUTTER selector

Set this selector to ON to use the electronic shutter. Push it down to SELECT to switch the shutter speed or mode setting within the range previously set with the setup menu.

When this selector is operated, the new setting appears on the setting change/adjustment progress message display area for about 3 seconds.

For details about the shutter speed and mode settings, see “4-2 Setting the Electronic Shutter” on page 63.

17 AUTO W/B BAL (automatic white/black balance adjustment) switch

This switch activates the white balance and black balance automatic adjustment functions.

WHT: Automatic adjustment of the white balance. If the WHITE BAL switch is set to A or B, the white balance setting is stored in the corresponding memory. The memory stores a separate white balance setting for each filter setting.

BLK: Automatic adjustment of the black set and black balance.

18 GAIN selector

This selector switches the gain of the video amplifier to match the lighting conditions during shooting. The gains corresponding to the L, M, and H settings can be selected from the setup menu. The factory settings are L = 0 dB, M = 9 dB, and H = 18 dB.

When this selector is adjusted, the new setting appears on the setting change/adjustment progress message display area of the viewfinder screen for about 3 seconds.

For details about setting the gain values, see “5-3-1 Setting Gain Values for the GAIN Selector Positions” on page 92.

19 OUTPUT/DCC (output signal/dynamic contrast control) selector

This selector switches the video signal that is output to the VTR, viewfinder, and video monitor, between the following two.

BARS: Outputs the color bar signal.

CAM: Outputs the video signal from the camera. When this is selected, you can switch DCC¹⁾ on and off with this selector.

1) DCC (Dynamic Contrast Control)

Against a very bright background with the iris opening adjusted to the subject, objects in the background will be lost in the glare. The DCC function will suppress the high intensity and restore much of the lost detail and is particularly effective in the following cases.

- Shooting people in the shade on a sunny day
- Shooting a subject indoors, against a background through a window
- Any high contrast scene

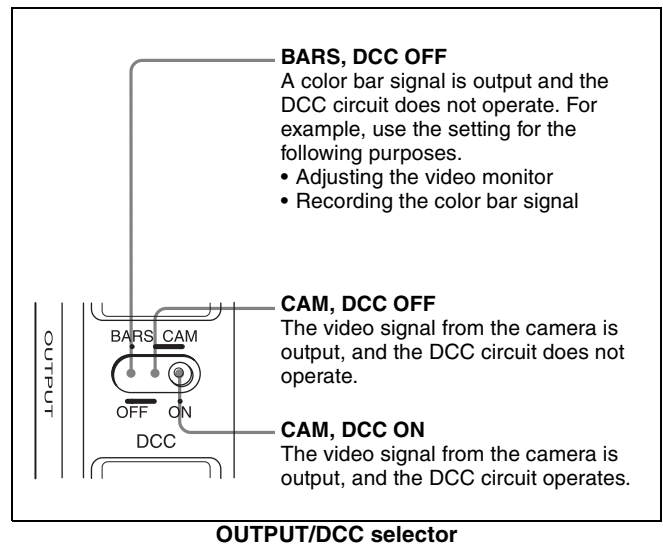

20 WHITE BAL (white balance memory) switch

This switch controls the white balance setting.

PRST (preset): Adjusts the color temperature corresponding to the position of the FILTER selector. Use the PRST setting when you have no time to adjust the white balance.

A or B: When the AUTO W/B BAL switch is pushed to WHT, the white balance is automatically adjusted according to the current position of the FILTER selector, and the adjusted value is stored in either memory A or memory B. (There are two memories for each filter, allowing a total of eight adjustments to be stored.) When this switch is set to A or B, the camcorder automatically adjusts itself to the stored value corresponding to the current settings of this switch and the FILTER selector.

You can use the AUTO W/B BAL switch even when ATW¹⁾ is in use.

1) ATW (Auto Tracing White Balance)

The white balance of the picture being shot is adjusted automatically for varying lighting conditions.

B (ATW): When this switch is set to B and on the FUNCTION 2 page of the OPERATION menu, “WHITE B CH” is set to “ATW”, ATW is activated.

When this switch is adjusted, the new setting appears on the setting change/adjustment progress message display area of the viewfinder screen for about 3 seconds. You can assign the ATW ON/OFF function to the ASSIGN 1 switch (push button) on the FUNCTION 1 page of the USER menu.

For details, see “5-3-5 Assigning Functions to Assignable Switches” on page 95.

21 TURBO GAIN button

When shooting under extremely poor lighting conditions, press the button once to boost the video gain to the value preset on the GAIN SW page of the USER menu (up to 48 dB). To stop boosting the gain, press the button once more.

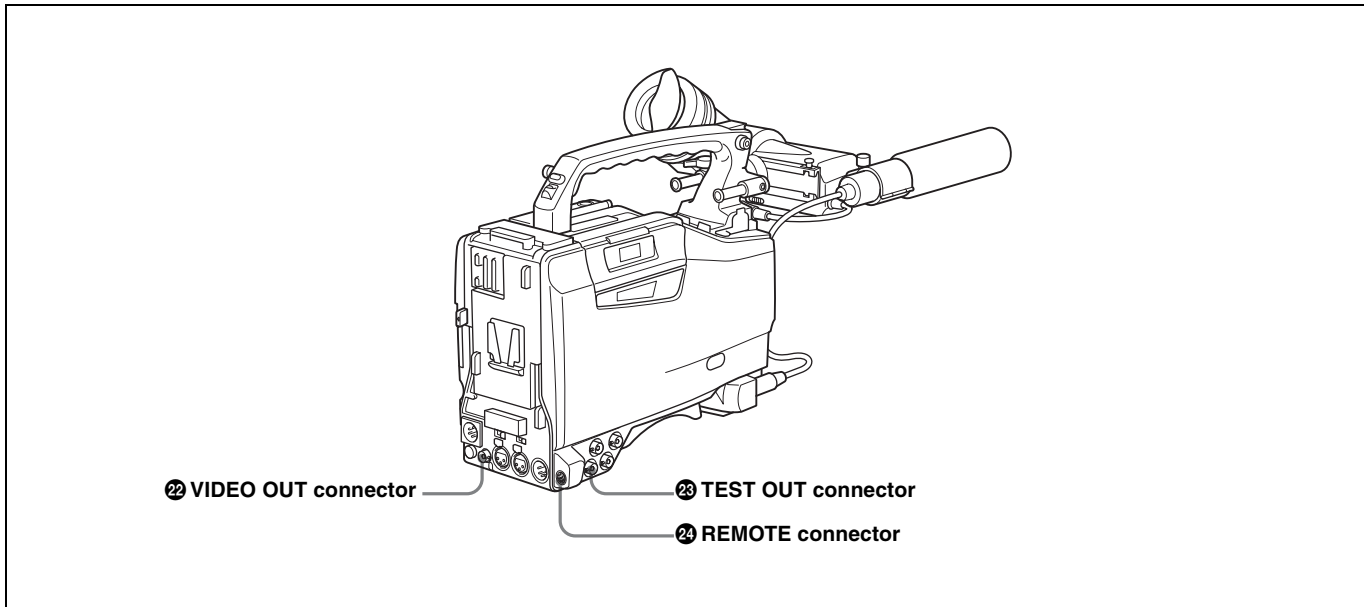

Shooting and recording/playback functions (3)

22 VIDEO OUT connector (BNC type)

This connector outputs a composite video signal (standard level, 75-ohm terminated) for a video monitor. With a video monitor connected to this connector, you can monitor the picture being shot by the camera or the picture played back by the VTR. To choose between the composite video signal output and SDI signal output, use the menu. When synchronizing the time code of an external VTR with that of the camcorder, connect this connector to the GENLOCK IN connector of the external VTR. By installing the CBK-SD01 extension board (not supplied), you can output an SDI signal (supporting embedded audio and the EDH function) from this connector.

For details on how to select the output signal, see “5-3-2 Selecting the Output Signals” on page 93.

23 TEST OUT connector (BNC type)

This connector outputs the video signal (standard level, 75-ohm terminated) for a video monitor. The output signal can be selected from composite or RGB. The factory setting is

composite, and the setting returns to composite whenever the unit is powered on.

Depending on menu settings, menus, time code, and shot data can be superimposed on the image on the monitor.

For details on how to select the test output signal, refer to the Maintenance Manual.

24 REMOTE connector (8-pin)

Connect the RM-B150/B750 Remote Control Unit, which makes it possible to control the VTR and camera remotely.

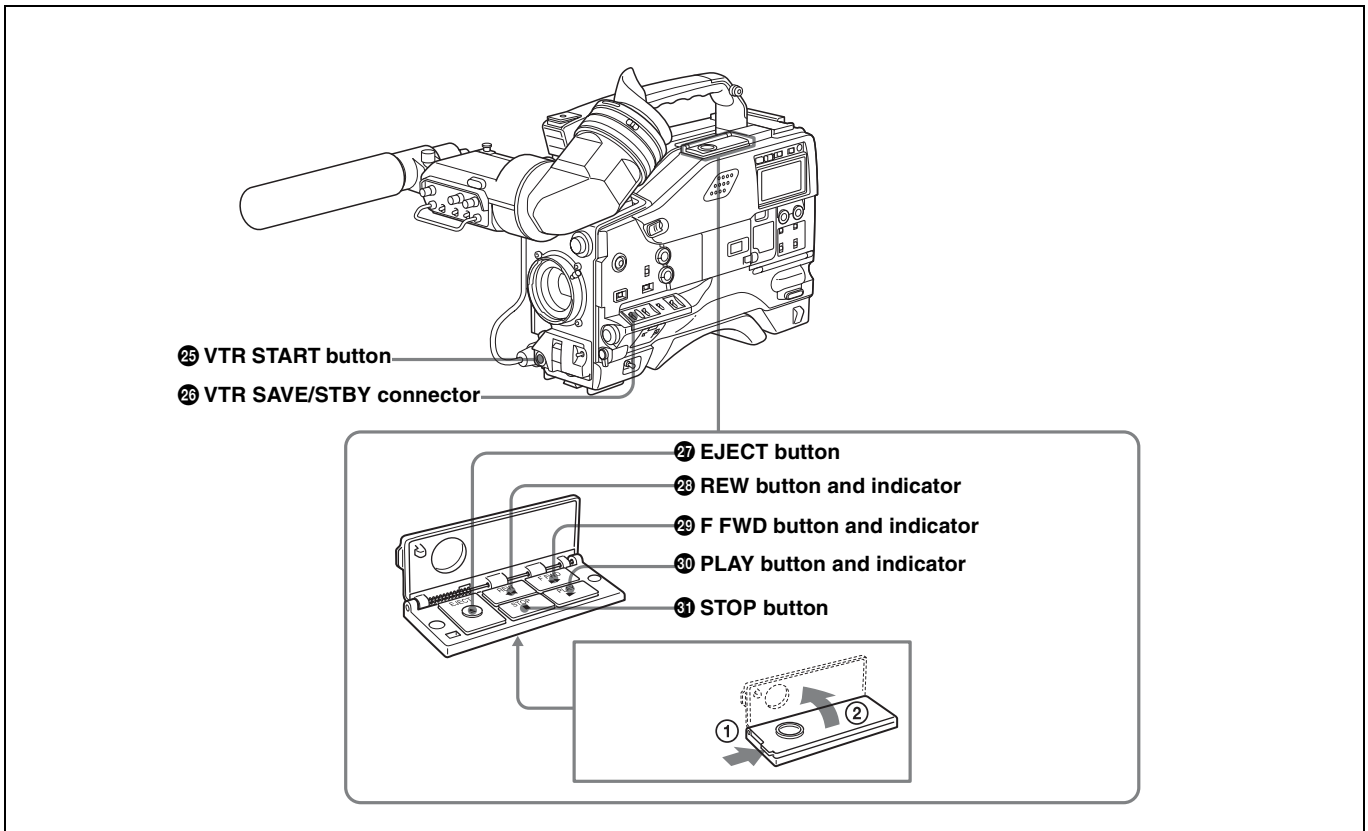

Shooting and recording/playback functions (4)

25 VTR START button

Press this button to start recording. Press it again to stop recording. The effect is exactly the same as that of the VTR button on the lens.

When the REC SWITCH function is assigned to the ASSIGN 1 switch (push button), you can use the switch as the REC START button.

26 VTR SAVE/STBY (standby) switch

This switch controls the VTR power mode during pauses in recording.

SAVE: Power saving mode. When you press the VTR START button, there is a short delay before recording starts, but power consumption in this mode is less than in standby mode, so that battery life is extended. When the switch is set to SAVE, the SAVE indicator in the viewfinder lights.

STBY: Standby mode. Recording starts as soon as you press the REC START button.

Notes

- Avoid allowing the camcorder to remain in STBY (standby) mode for a long time.
- Even if the switch is set to the STBY position, the camcorder can automatically turn to power saving mode if the tape does not run for a certain period. In such a case, the VTR SAVE indicator in the viewfinder lights. This function is effective when a setting other than OFF is selected for the STBY OFF TIMER item on the VTR

MODE page of the MAINTENANCE menu. The STBY OFF TIMER item also allows you to select the length of time until the camcorder turns to power saving mode.

For detailed information, see “3-7 Setting the Stand-by off Timer During Rec-Pause” on page 59.

27 EJECT button

Press this button to eject or load a cassette.

28 REW (rewind) button and indicator

Press this button to rewind the tape. The indicator lights during rewinding.

29 F FWD (fast forward) button and indicator

Press this button to fast forward the tape. The indicator lights during fast forward.

30 PLAY button and indicator

Press this button to view the recorded picture in the viewfinder or on the color video monitor. The indicator lights during playback. The 4 times normal speed search function is provided to make it far quicker to find a desired location of the tape. Press the REW button or F FWD button during playback to view the 4 times normal speed search picture.

31 STOP button

Press this button to stop the tape.

2-5 Menu Operating Section

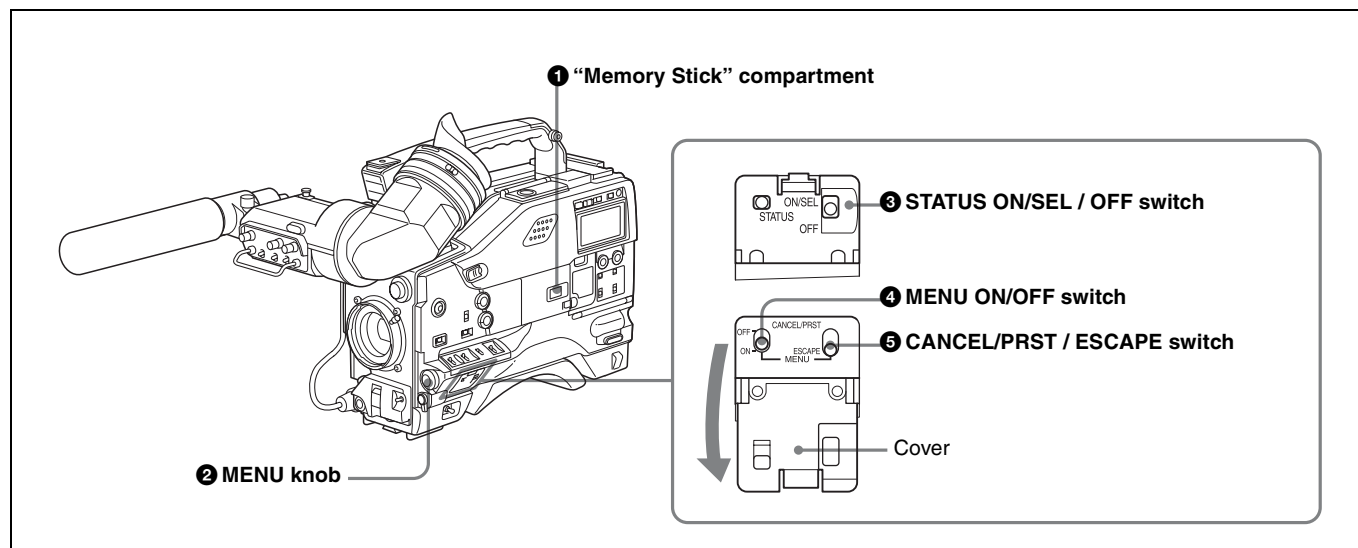

Menu operation section

1 "Memory Stick" compartment

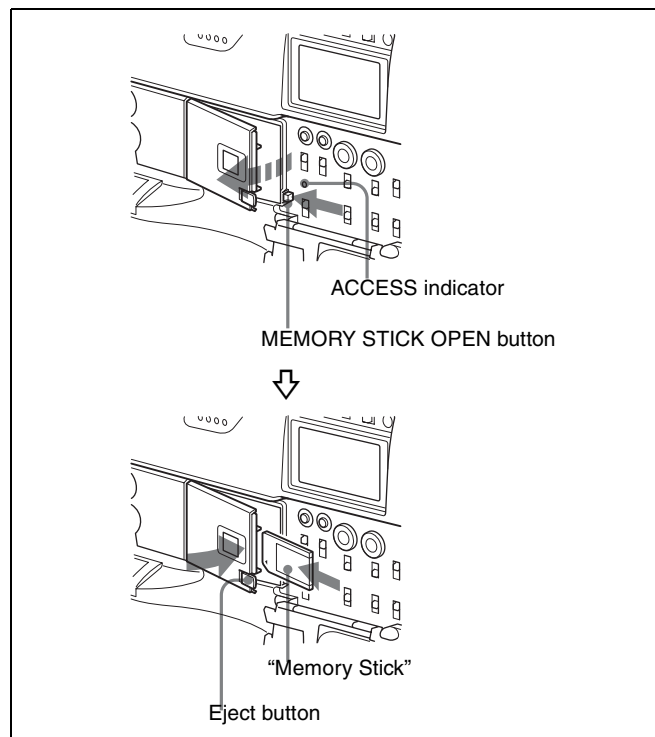

Open the cover of the "Memory Stick" compartment by pressing the MEMORY STICK OPEN button and insert the "Memory Stick."

To remove, press the eject button.

During data writing/loading to/from the "Memory Stick," the ACCESS indicator lights or flashes.

For details, see "6-1-1 Handling the "Memory Stick"" on page 105.

2 MENU knob

Use this knob to change the page selection or a setting within the menu.

Press: If you press this knob when the arrow (➔) is placed at the page title on the menu, the arrow changes to a question mark (?) and you can change the page by turning this knob.

When the arrow mark is placed at a position other than the page title, you can change the setting of the current item by pressing and turning this knob.

Turn: Turn this knob to change the page or change item settings.

3 STATUS ON/SEL / OFF (menu display on/page selection/display off) switch

To enable this switch, set the MENU ON/OFF switch to OFF.

Closing the cover automatically sets the MENU ON/OFF switch to OFF.

ON/SEL: Each time this switch is pushed upward, a window to confirm the menu settings and status of the camcorder appears on the viewfinder screen. The window consists of three pages, which are switched each time the switch is pushed upward. Each page is displayed for about 10 seconds.

OFF: To clear the page immediately after display, push this switch down to the OFF position.

You can select the pages to be displayed on the menu.

For details, see "5-2-8 Displaying the Status Confirmation Windows" on page 89.

4 MENU ON/OFF switch

To use this switch, open the cover.

This switch is used to display the menu on the viewfinder screen or the test signal screen.

Closing the cover automatically sets this switch to OFF.

ON: Displays the menu on the viewfinder screen or the test signal screen, at the last accessed page. When the menu is used for the first time, the first page is displayed.

OFF: Removes the menu from the viewfinder screen or the test signal screen.

⑤ CANCEL/PRST (preset) / ESCAPE switch

To enable this switch, set the MENU ON/OFF switch to ON.

Closing the cover automatically sets the MENU ON/OFF switch to OFF.

CANCEL/PRST: Pushing this switch up to this position displays the message to confirm whether the previous settings are cancelled or settings are reset to their initial values, depending on the menu operating condition. Pushing this switch up to this position again cancels the previous settings or resets the settings to their initial values.

ESCAPE: Use this switch when the menu page, which has a hierarchical structure, is opened. Each time the switch is pushed to this position, the page returns to one stage higher in the hierarchy.

2-6 Time Code System

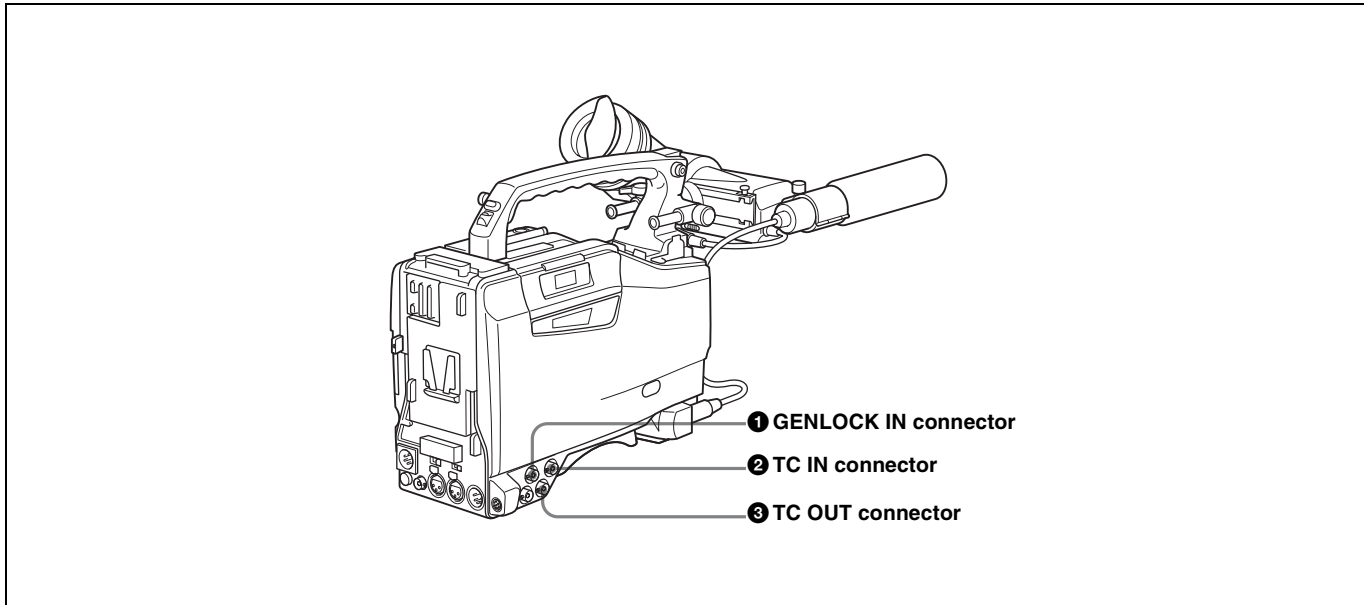

Time code functions (1)

❶ GENLOCK IN connector (BNC type)

- This connector accepts a reference signal when the camera is to be genlocked or when the time code is to be synchronized with external equipment. Use the items GL H PHASE, GL SC PHASE and GL SC 0/180 SEL on the GENLOCK page of the MAINTENANCE menu to adjust the genlock H-phase (phase of horizontal sync signal) and the sub-carrier phase.
- This connector also accepts a return video signal. You can display the return video signal in the viewfinder screen while holding the RET button down with “RETURN VIDEO” set to “ON” on the GENLOCK page of the OPERATION menu.
- This connector also accepts an external analog composite video signal. When the MSDW-904 extension board (optional) is installed, you can record the external analog composite video signal input to this connector.

For details, see “3-5 Recording Video Signals from External Equipment (When Using an MSDW-904)” on page 55.

❷ TC IN (time code input) connector (BNC type)

To synchronize the time code of this unit to an external time code, input the reference time code to this connector.

❸ TC OUT (time code output) connector (BNC type)

To synchronize the time code of an external VTR to that of the camcorder, connect this connector to the reference time code input connector of the external VTR.

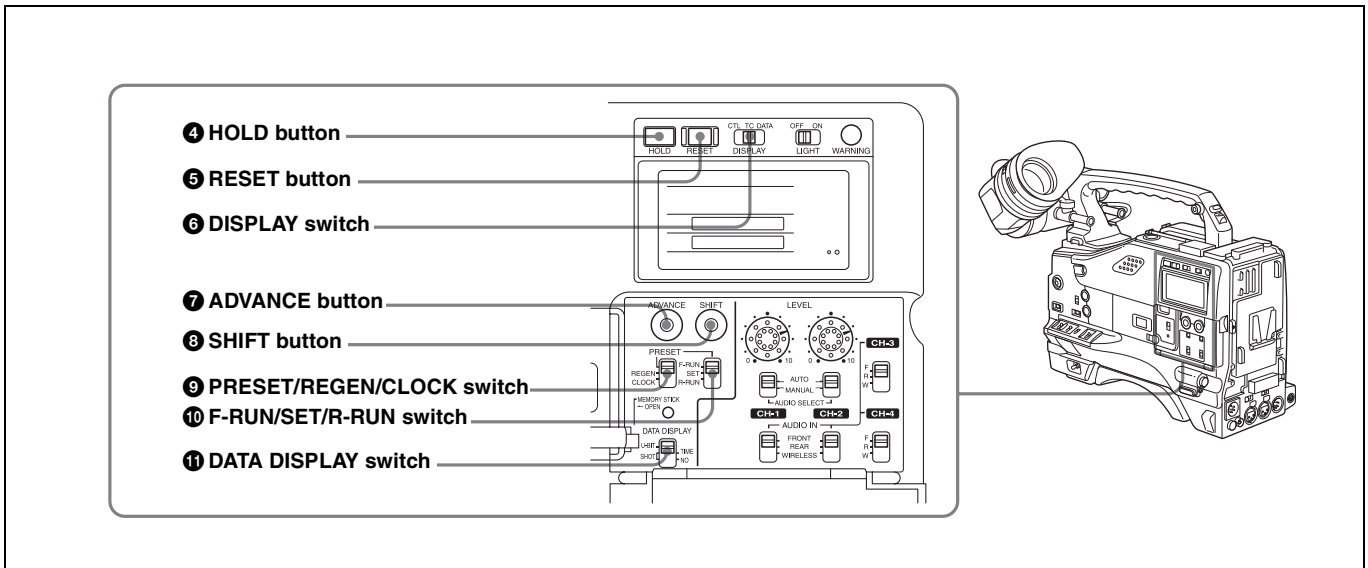

Time code functions (2)

4 HOLD (display hold) button

Pressing this button instantly freezes the time data displayed in the counter display section. (The time code generator continues running.) Pressing this button again releases the hold. You can use this button, for example, to determine the exact time of a particular shot. When the HOLD button is activated, the time data is displayed in the following format:

00:00:00:00

For details of the counter display, see “2-8 Warnings and Indications on the Display Panel” on page 31.

5 RESET button

Pressing this button resets the time data displayed on the counter display section to “00:00:00:00” or the user bit data to “00000000.”

6 DISPLAY (LCD display) switch

CTL: Control signal

TC: Time code

DATA: The item selected by the DATA DISPLAY switch.

For details, see “Time code display” on page 32.

7 ADVANCE button

For setting the time code, user bits, or real time, each press of this button increments the flashing digit selected by the SHIFT button.

8 SHIFT button

For setting the time code, user bits, or real time, this button selects the digit to be changed. The selected digit flashes.

9 PRESET/REGEN (regeneration)/CLOCK switch

This switch selects whether to set a new time code or to follow the already recorded time code.

PRESET: Records time code with a preset initial value.

REGEN: Records time code continuous with the existing time code recorded on the tape. Regardless of the setting of the F-RUN/SET/R-RUN switch, the camcorder operates in R-RUN mode.

CLOCK: Records time code synchronized to the internal clock. Regardless of the setting of the F-RUN/SET/R-RUN switch, the camcorder operates in F-RUN mode.

For more information, see “To make the time code consecutive” on page 72.

10 F-RUN/SET/R-RUN (free run/set/recording run) switch

This switch selects the operating mode for the internal time code generator.

F-RUN: Time code keeps advancing, regardless of the operating state of the VTR. Use this setting when aligning the time code with real time or when synchronizing the time code with an external time code.

SET: Set the switch to this position to set the time code or user bits.

R-RUN: The time code value advances only during recording. Use this setting to have a consecutive time code on the tape.

For details, see “4-5-1 Setting the Time Code” on page 71 and “4-5-3 Setting the User Bits” on page 72.

11 DATA DISPLAY switch

U-BIT: To display the user bit value

SHOT-TIME: To display the date and time from the shot data

SHOT-NO: Not used

2-7 Warnings and Indications

Besides the viewfinder, speaker and earphones, the indicators and displays described in this section also provide you with information such as the operating state of the camcorder and warnings.

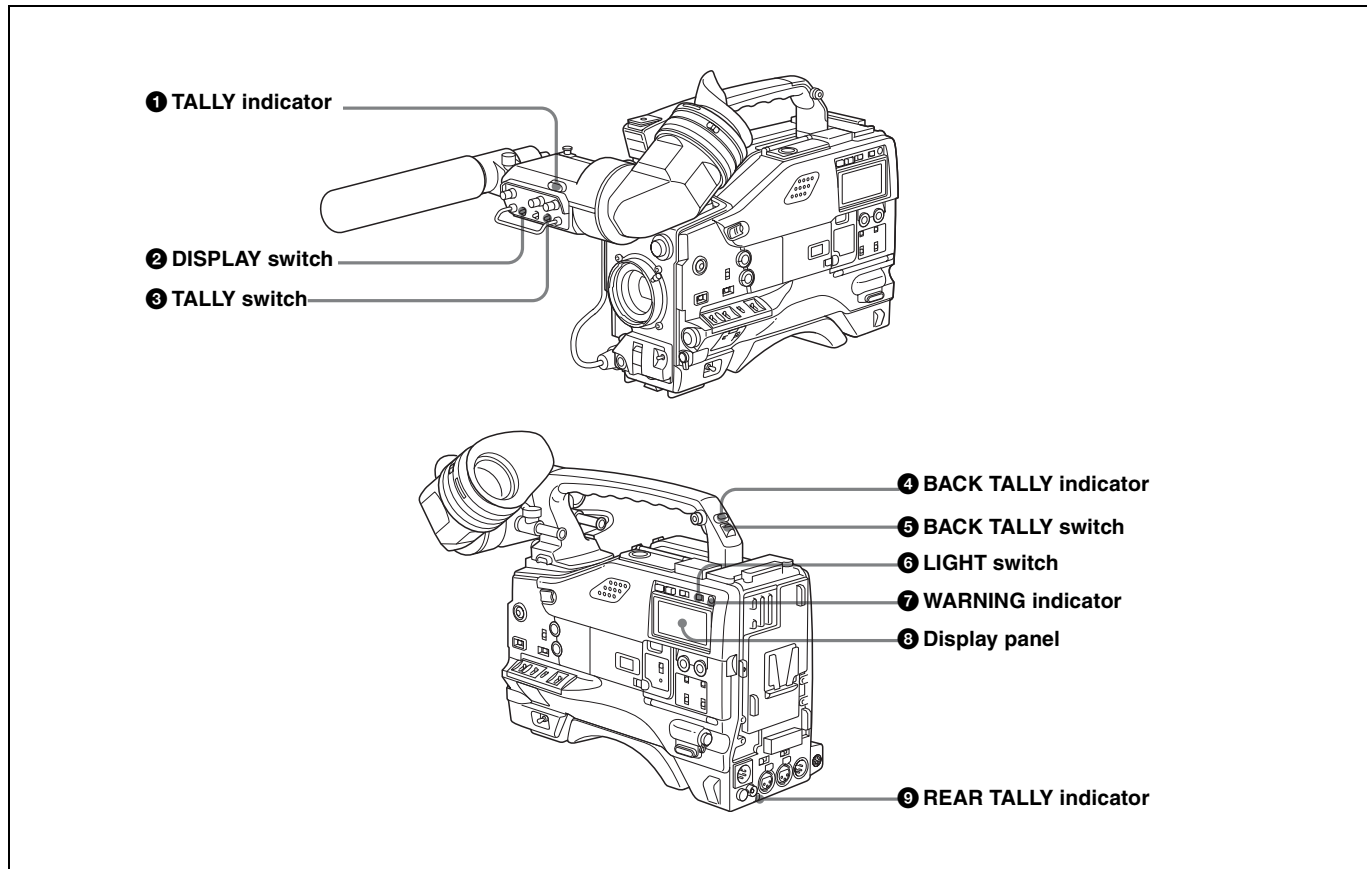

Warning and indication functions

1 TALLY indicator

Setting the TALLY switch on the viewfinder to HIGH or LOW enables this indicator. It lights when the VTR starts recording. Like the REC indicator in the viewfinder, it also flashes to provide warnings. The brightness of this indicator when it is lit can be switched with the TALLY switch.

2 DISPLAY switch

This switches the indications on the viewfinder screen on or off.

ON: The indications appear on the viewfinder screen.

OFF: The indications do not appear on the viewfinder screen.

Note

Setting the MENU ON/OFF switch to ON displays the menu on the viewfinder screen even if the DISPLAY switch is set to OFF.

3 TALLY switch

This switch controls the TALLY indicator as follows:

HIGH: The TALLY indicator brightness is high.

OFF: The TALLY indicator is disabled.

LOW: The TALLY indicator brightness is low.

4 BACK TALLY indicator

When the BACK TALLY switch is set to ON, this indicator has the same function as the TALLY indicator.

5 BACK TALLY switch

This switch enables or disables the BACK TALLY and REAR TALLY indicators.

ON: The BACK TALLY and REAR TALLY indicators are enabled.

OFF: The BACK TALLY and REAR TALLY indicators are disabled.

6 LIGHT switch

This switch turns on/off the display panel light.

7 WARNING indicator

This indicator lights up or flashes when there is a fault in the VTR.

For details, see “8-3 Operation Warnings” on page 134.

8 Display panel

This displays VTR-related warnings, battery status, tape status, audio levels, time data, and so on.

For details, see “2-8 Warnings and Indications on the Display Panel” on page 31.

9 REAR TALLY indicator

When the BACK TALLY switch is set to ON, this indicator has the same function as the TALLY indicator.

2-8 Warnings and Indications on the Display Panel

Tape status, battery status and audio level

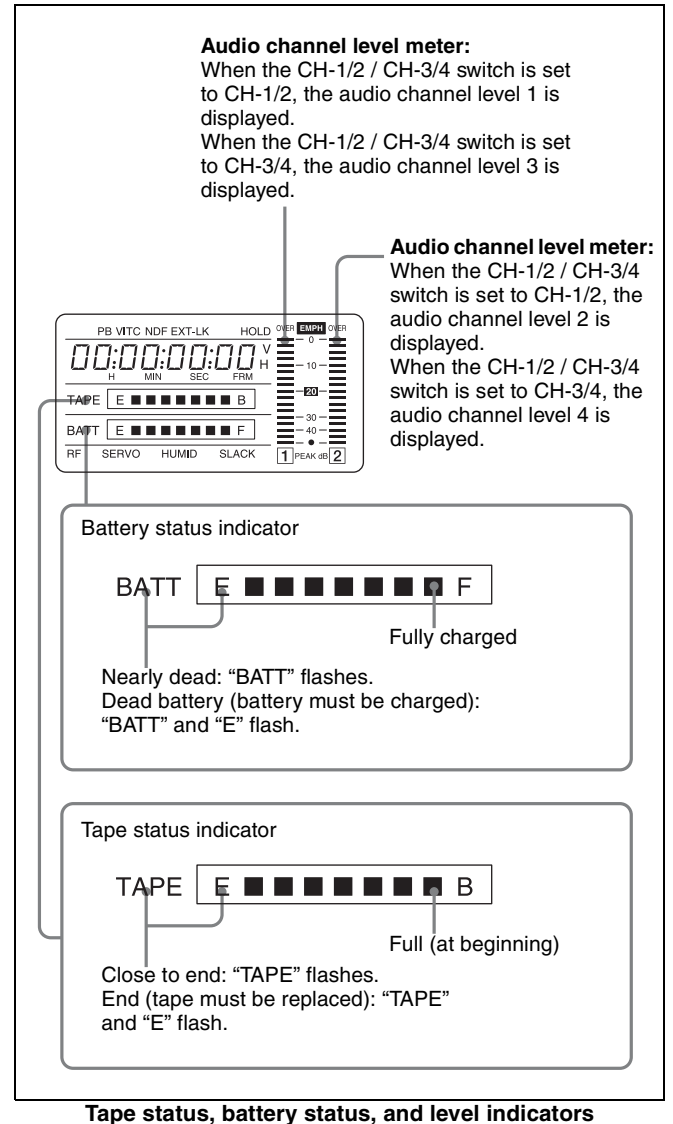

VTR operation status and status indicators

Lights during playback

RF VITC NDF EXT-LK HOLD OVER EMPH OVER

00:00:00:00
H MIN SEC FRM

TAPE E ■■■■■ B

BATT E ■■■■■ F

RF SERVO HUMID SLACK 1 PEAK 2

Warning indication
RF: Lights if the recording heads are clogged.
SERVO: Lights if the servo motor fails.
HUMID: Lights if condensation is on the drum.
SLACK: Lights if the tape is not winding properly.
 For details, see "8-3 Operation Warnings" on page 134.

VTR operation and status indicators

Time code display

Lights in playback mode.

Lights when VITC is selected for the time code.

Lights in non-drop frame mode. (MSW-970 only)

Lights when the camcorder is synchronized with an external time code.

Lights when the time code generator is on hold.

RF VITC NDF EXT-LK HOLD OVER EMPH OVER

00:00:00:00
H MIN SEC FRM

TAPE E ■■■■■ B

BATT E ■■■■■ F

RF SERVO HUMID SLACK 1 PEAK 2

Lights when the time code, CTL or real time is displayed.

Lights when the HOLD button is pressed.¹⁾

Time counter display: Shows the time code, CTL, user bit data, and real time.

1) When the HOLD button is pressed to hold the time code value, the time code is displayed in the format shown below. When the HOLD button is pressed again to release the hold, the time code is displayed in the normal format.

00:00:00:00

Time code display

Relationships between the DISPLAY switch and DATA DISPLAY switch settings and the time counter displays

Except during setting of the time code, the time counter display is determined by the position of the DISPLAY switch and DATA DISPLAY switch.

For details of setting the time code menu operation, see "4-5-1 Setting the Time Code" on page 71.

Switch settings related to time code and displayed information

DISPLAY switch position	DATA DISPLAY switch position	Displayed information
CTL	Any position	CTL
TC	Any position	Time code
DATA	U-BIT	User bits
	SHOT-TIME	Data and time from shot data
	SHOT-NO	Not used (currently zero is displayed.)

2-9 Indicators in the Viewfinder

Several indicators are provided above and below the viewfinder screen to indicate the current state and adjustments of the camera.

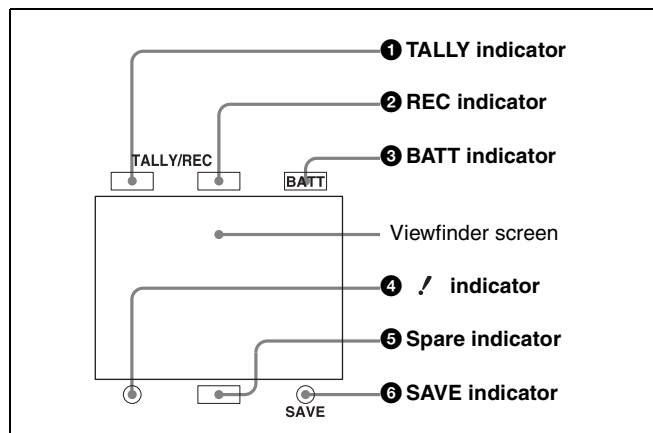

Indicators on the viewfinder

1 TALLY (green tally) indicator

This indicator lights when the camcorder is in Picture Cache mode. Also, this indicator lights when a green tally signal is received from the camera control unit. It flashes in Interval Rec mode.

2 REC (recording, red tally) indicator

This indicator lights red when recording starts and remains lit during recording. It also lights when a red tally signal is received from the camera control unit and flashes to give a warning.

For details, see “8-3 Operation Warnings” on page 134.

3 BATT (battery) indicator

This indicator starts flashing when the battery connected to the camcorder is nearly exhausted, and stays lit when the battery is completely exhausted.

The battery power level at which the indicator starts flashing can be set on the BATTERY page of the MAINTENANCE menu.

For details, refer to the Maintenance Manual.

4 ! (warning) indicator

This indicator lights when any of the following conditions occurs with the corresponding item set to ON on the “!” LED page of the USER menu.

- The gain is set to other than 0 dB.
- The SHUTTER selector is set to ON.
- The WHITE BAL switch is set to PRST.
- ATW is enabled.
- The lens extender is used.

- The FILTER selector is set to other than ND:1/CC:B.
- The reference value of auto iris override is not the standard value.

5 Spare indicator

This is a spare indicator. Setting the REC TALLY item to “BOTH” on the FUNCTION 3 page of the MAINTENANCE menu makes it possible to use this as a REC indicator.

6 SAVE indicator

This indicator lights when the VTR SAVE/STBY switch is set to SAVE, putting the VTR into power save mode.

3-1 About Cassette

This section describes the procedure for loading and unloading a cassette.

See Specifications "VTR Section" on page 137 for information about the cassettes you can use in the camcorder.

3-1-1 Loading and Unloading a Cassette

Loading a cassette

- 1 Turn on the POWER switch.

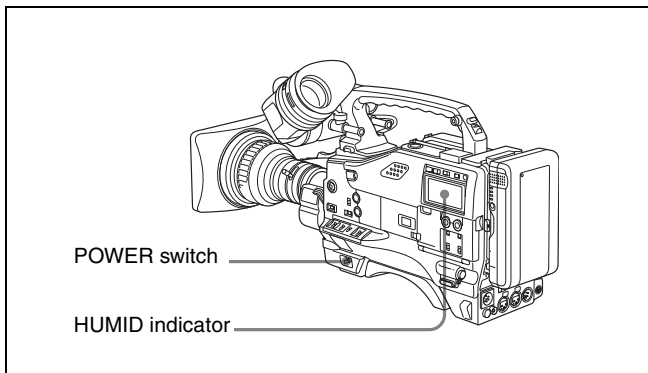

Note

If the interior of the VTR section is damp, the HUMID indicator will light. If this happens, wait until the indicator goes off before going on to step 2.

- 2 Press the EJECT button.

The cassette compartment lid will open.

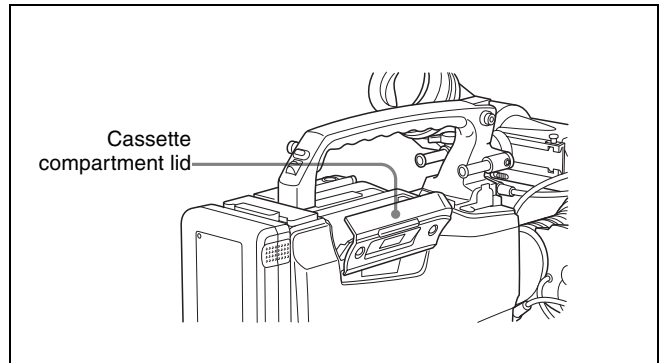

- 3 Check that there is no slack in the tape. Then slide in the cassette until it clicks into position and close the cassette lid completely by pressing near the engraved PUSH.

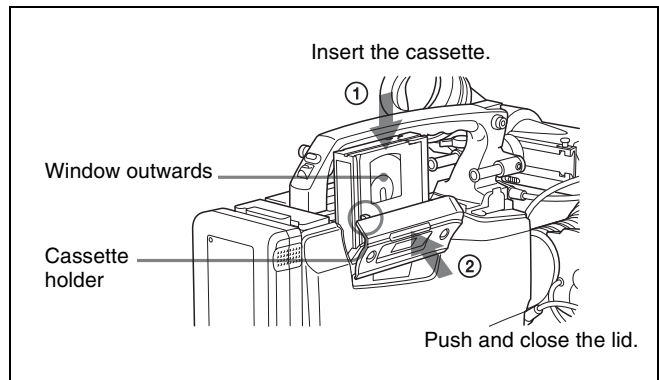

Notes

- To insert the tape correctly, make sure to stand the grip of the camcorder.
- When inserting the tape, be careful that you don't hit the tape against the tape holder.

Checking the tape for slack

Pressing in the reels lightly, turn them gently with your fingers in the directions shown below. If the reels will not move, there is no slack.

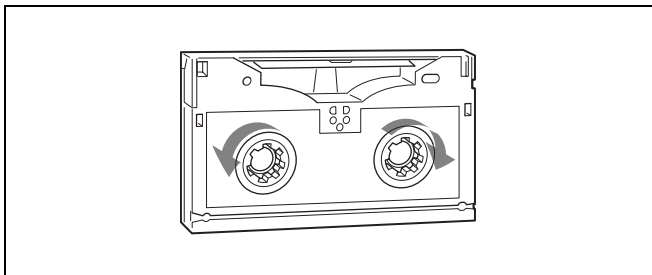

Checking the tape for slack

3-1-2 Preventing Accidental Erasure

The following procedure prevents cassettes from being recorded inadvertently.

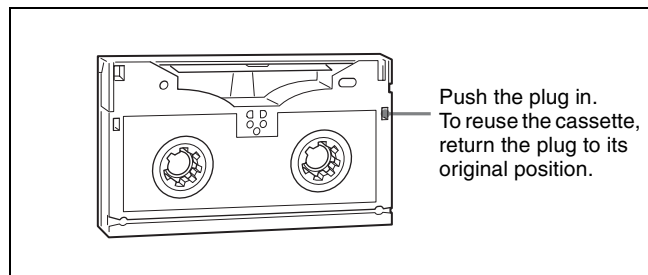

Push the plug in.
To reuse the cassette,
return the plug to its
original position.

Preventing accidental erasure

Unloading a cassette

With the power supply on, press the EJECT button to open the cassette compartment lid. Then take out the cassette. If you are not going to insert another cassette, close the cassette lid.

It is possible to take out the cassette and close the cassette compartment lid unless the battery voltage drops below about 10.5 V. Do not repeat this unloading operation.

Unloading a cassette manually

If the battery voltage drops below about 10.5 V, take out the cassette manually as illustrated below.

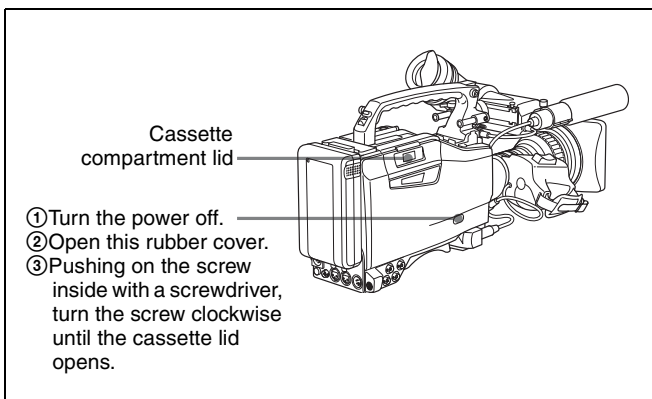

Cassette
compartment lid

- ① Turn the power off.
- ② Open this rubber cover.
- ③ Pushing on the screw inside with a screwdriver, turn the screw clockwise until the cassette lid opens.

Unloading a cassette manually

You need not return the screw to its original position after taking out the cassette. Although the cassette compartment lid is not locked, turning on the power makes the cassette lid operable again.

3-2 Recording

3-2-1 Basic Procedures

This section describes the basic procedures for shooting and recording.

Before a shooting session, ensure that the camcorder is functioning properly.

For details, see “8-1 Testing the Camcorder Before Shooting” on page 129.

From turning on the camcorder to loading a cassette

Proceed as follows:

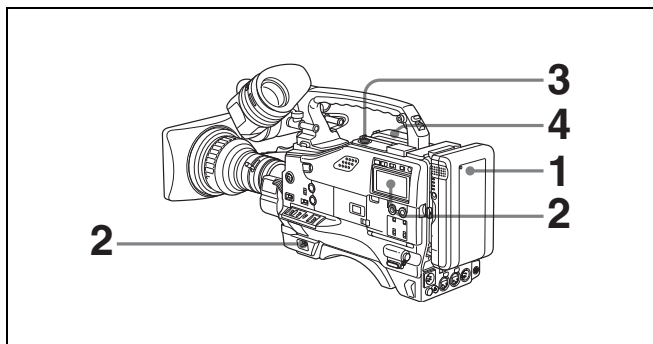

Basic procedure for shooting: from power supply to cassette loading

- 1 Attach a fully charged battery pack.
For details, see “7-1 Power Supply” on page 115.
- 2 Set the POWER switch to ON. Check that the HUMID indicator does not appear and that the battery power level is sufficient.

If HUMID indicator appears, wait until it disappears.

Note

After turning off the power, check whether the drum is dry (even if the HUMID indicator is off) when the turning on the power again.

- 3 Check that there are no obstructions near the cassette lid. Then press the EJECT button to open the cassette lid.
- 4 After checking the points below, load the cassette and close the cassette lid.
 - The cassette is not write-protected.
 - There is no slack in the tape.

From adjusting the black balance and white balance to stopping recording

After turning on the power and loading a cassette, set the switches and selectors as shown below and begin operation.

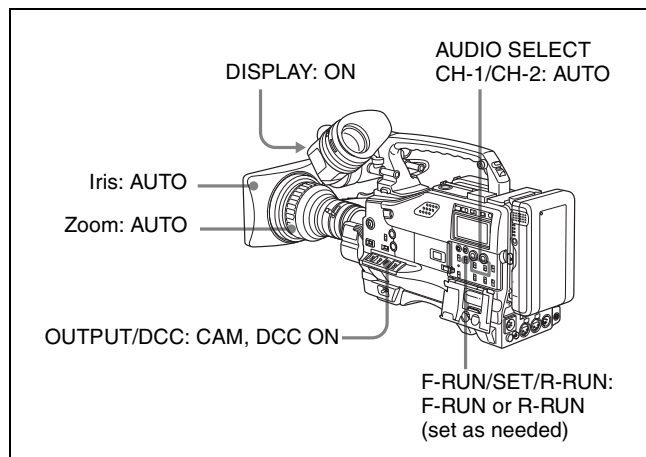

Switch and selector settings before shooting

Shooting

Proceed as follows:

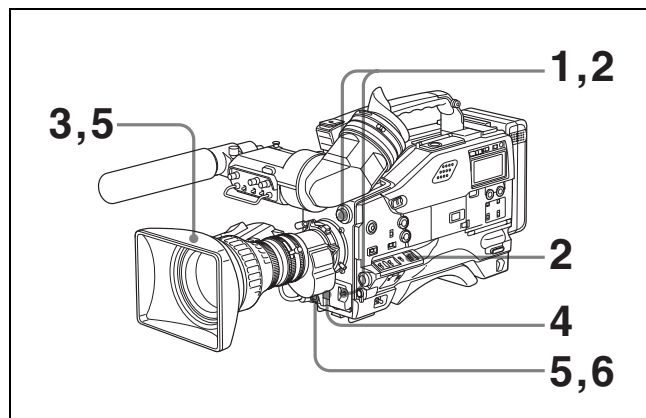

Basic procedure for shooting: from adjusting the black balance and white balance to stopping recording

- 1 Push the AUTO W/B BAL switch to BLK to adjust the black balance.
For details of black balance adjustment, see “4-1-1 Adjusting the Black Balance” on page 60.
- 2 Select the CC filter and ND filter to match the lighting conditions, and adjust the white balance.

When the white balance settings are already in memory

Set the WHITE BAL switch to A or B.

When the white balance setting is not in memory and you do not have enough time to adjust the white balance

Set the WHITE BAL switch to PRST.

This automatically adjusts the white balance as follows, depending on the setting of the FILTER knob.
B: 3200K
C: 4300K
D: 6300K

For details, see “4-1-2 Adjusting the White Balance” on page 61.

3 Aim the camera at the subject and adjust the focus and zoom.

4 If necessary, set the electronic shutter for an appropriate mode and speed.

For details, see “4-2 Setting the Electronic Shutter” on page 63.

5 To start recording, press the VTR START button or the VTR button on the lens.

If the recording start/stop function is assigned to the ASSIGN 1 switch, this switch functions as VTR START button.

For details, see “5-3-5 Assigning Functions to Assignable Switches” on page 95.

During recording, the REC indicator lights in the viewfinder. Perform zooming and focus control, if necessary.

6 To stop recording, press the VTR START button or the VTR button on the lens again.

The REC indicator in the viewfinder goes off.

Cassette control buttons

During recording, the cassette control buttons (EJECT, REW, F FWD, PLAY, STOP) have no effect.

Note

When crash-recording without doing continuous recording on a recorded tape, or when recording with the RE-TAKE function, the timecode recorded previously may be displayed for a few seconds when playing back the first part of the cut.

3-2-2 Continuous Recording

If the camcorder is in the recording pause mode, simply pressing the VTR START button on the camcorder or the VTR button on the lens continues recording exactly from the next frame.

In other cases, you first need to position the tape at an appropriate point.

When the camcorder is in Recording Pause mode

Pressing the VTR START button on the camcorder or the VTR button on the lens continues recording at exactly the next frame. However, the time taken before recording starts depends on the setting of the VTR SAVE/STBY switch.

- If the VTR SAVE/STBY switch is in the SAVE position, it takes about 4 seconds before recording starts.
- If the VTR SAVE/STBY switch is in the STBY position, recording starts immediately. However, just after the switch position is changed from SAVE to STBY, it takes about 4 seconds before recording starts.

If you turn off the power during a recording pause

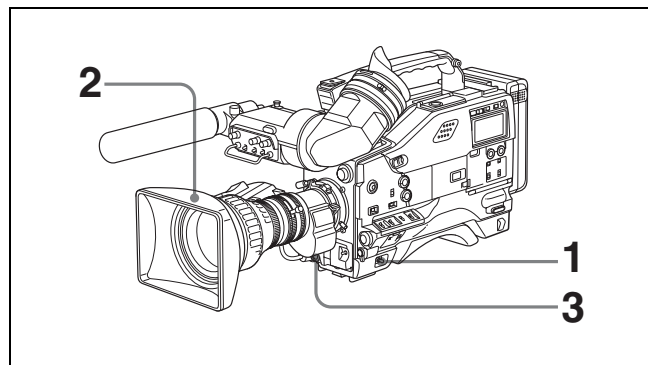

Continuous recording after turning off the power during a recording pause

- 1** Turn on the power again.
- 2** Press the RET button on the lens.

If an analog composite signal is input to the GENLOCK IN connector, make sure that RETURN VIDEO is set to OFF on the GENLOCK page of the MAINTENANCE menu.

The camcorder positions the tape at the appropriate point. Note, however, that this function works only for continuously recorded material or consecutively joined segments totaling at least 3 seconds in length.

- 3** Press the VTR START button on the camcorder or the VTR button on the lens to start recording.

Continuous recording in other cases

After rewinding or fast forward, after removing the cassette, or on a tape that has been partially recorded, you can obtain a continuous recording by following the procedure below.

The End Search function also allows you to continue recording on the partially recorded tape.

For details, see “3-2-7 Searching for the Last Recorded Portion and Turning in Recording Pause Mode (End Search Function)” on page 51.

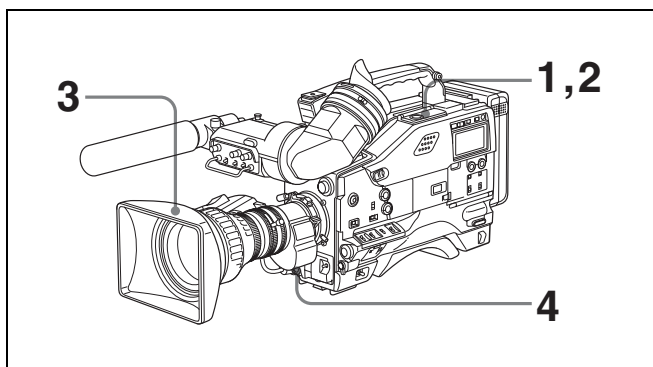

Continuous recording after rewinding or fast forward, after removing the cassette, or on a tape that has been partly recorded

- 1** Looking in the viewfinder, press the PLAY button to start playback.
- 2** Press the STOP button at the desired point to begin recording. To continue from the end of recording already on the tape, press the STOP button immediately after the end of the previous recording (within 0.5 seconds).
- 3** Press the RET button.
The tape will rewind and will be positioned at the desired point to continue recording.
- 4** Press the VTR START button on the camcorder or the VTR button on the lens to start recording.

3-2-3 Recording Essence Marks

Various essence marks, such as shot marks, can be recorded on tape. Recording essence marks for scenes containing important images and sounds enables quick access to the marked points. This increases editing efficiency.

There are essence marks that are automatically recorded by starting recording or firing the flash and those you can manually record when necessary.

Note

For good shot marks (shot mark 1 and shot mark 2) and recording start mark among available essence marks, you can select recording in the LTC-UBIT area and/or recording in the system area as required to maintain compatibility with conventional systems.

Settings for recording essence marks to the system area

Settings on the ESSENCE MARK and ESSENCE MARK2 pages of the MAINTENANCE menu determine which essence marks are to be recorded on the system area of tape.

Follow the procedures below:

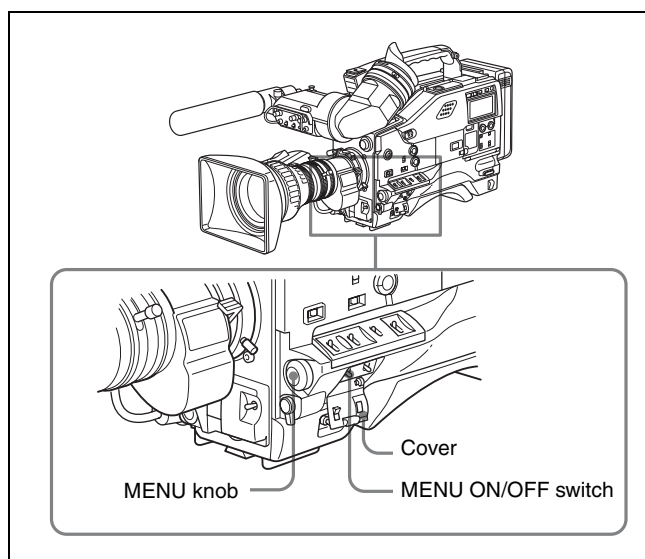

- 1** Set the MENU ON/OFF switch to ON while pushing the MENU knob.

The TOP menu appears.

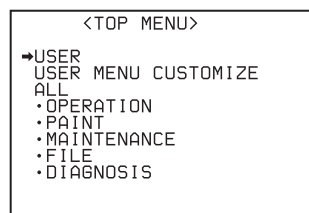

- 2** Turn the MENU knob to move the → mark to MAINTENANCE.
- 3** Push the MENU knob.

When the MAINTENANCE menu is first used, the CONTENTS page appears.

Or if you have used the MAINTENANCE menu already, the page that was on the screen when the last menu operation ended appears.

- When the CONTENTS page is displayed, turn the MENU knob to move the **▶** mark to ESSENCE MARK then push the MENU knob.

When any page of the MAINTENANCE menu is displayed, turn the MENU knob until the ESSENCE MARK or ESSENCE MARK2 page appears, then push the MENU knob.

ESSENCE MARK page

?M100ESSENCE MARK	
LTC UB-MARKER	: SET
REC START MARK	: OFF
SHOTMARK 1	: OFF
SHOTMARK 2	: OFF
SHOT TIME DISP	: MD:HM

ESSENCE MARK2 page

?M110ESSENCE MARK2	
OVER AUDIO LIMIT	: ON
GAIN CHG MARK	: ON
FILTER CHG MARK	: ON
SHUTTER CHG MARK	: ON
WHITE CHG MARK	: ON
FLASH MARK	: ON
FLASH MARK LEVEL	: 10
E.MARK SD LINE	: 17

The following items on these pages are for setting the corresponding essence marks:

Mark	Condition
REC START MARK	To be recorded when recording starts.
SHOT MARK 1/2	To be recorded when the RET button on the lens is manually operated.
OVER AUDIO LIMIT	To be recorded when the audio level exceeds 0 dBFS.
GAIN CHG MARK	To be recorded when the gain value changes.
FILTER CHG MARK	To be recorded when the filter is changed.
SHUTTER CHG MARK	To be recorded when the shutter speed changes.
WHITE CHG MARK	To be recorded when the white balance changes.
FLASH MARK	To be recorded when the luminance suddenly changes, such as when the flash is exposed or the unit is moved indoors from outdoors.

You can check whether any of the essence marks that are automatically recorded (OVER AUDIO LIMIT, GAIN CHG MARK, FILTER CHG MARK, SHUTTER CHG MARK, WHITE CHG MARK, FLASH MARK) has been recorded, by setting the display for recorded essence marks ON.

For details on the display setting, see “5-2 Status Display on the Viewfinder Screen” (page 82).

- Turn the MENU knob to move the **▶** mark to the item to be set.

M100ESSENCE MARK	
LTC UB-MARKER	: SET
REC START MARK	: OFF
▶SHOTMARK 1	: ● OFF
SHOTMARK 2	: OFF
SHOT TIME DISP	: MD:HM

- Push the MENU knob.

The **▶** mark to the left of the item changes to the **●** mark, and the **●** mark to the left of the setting changes to the **?** mark.

- Turn the MENU knob clockwise or counter clockwise until the desired setting appears.
To record the mark on tape, select ON.
To not record the mark, select OFF.

Note

Whether or not to record good shot marks (shot mark 1 and shot mark 2) and recording start mark in the system area is determined by the ON/OFF settings of the corresponding items regardless of the LTC UB-MARKER setting on the ESSENCE MARK page.

- Push the MENU knob.
- Perform settings for the remaining marks, repeating steps 5 to 8.
- When you set FLASH MARK to ON, select the threshold value (1 to 20) of the luminance level change for recording the mark.
- Set the MENU ON/OFF switch to OFF to end the menu operation.

Settings for recording good shot marks and recording start mark to the LTC-UBIT area

Good shot marks (shot mark 1 and shot mark 2) and recording start mark can also be recorded to the LTC-UBIT area of tape.

Follow the procedures below:

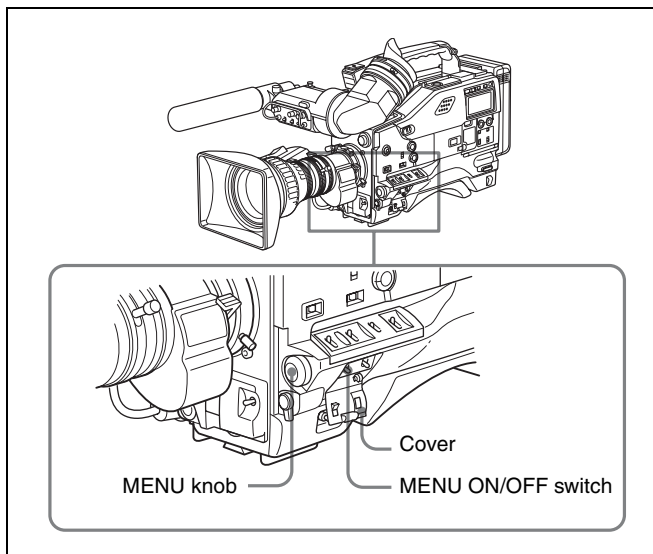

- 1 Set the MENU ON/OFF switch to ON while pushing the MENU knob.

The TOP menu appears.

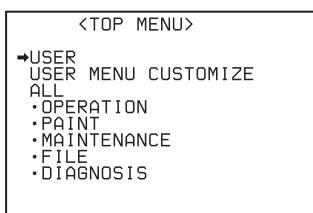

- 2 Turn the MENU knob to move the ► mark to MAINTENANCE.

- 3 Push the MENU knob.

When the MAINTENANCE menu is first used, the CONTENTS page appears.

Or if you have used the MAINTENANCE menu already, the page that was on the screen when the last menu operation ended appears.

- 4 When the CONTENTS page is displayed, turn the MENU knob to move the ► mark to ESSENCE MARK then push the MENU knob.

When any page of the MAINTENANCE menu is displayed, turn the MENU knob until the ESSENCE MARK page appears, then push the MENU knob.

ESSENCE MARK page

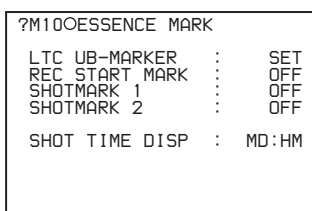

- 5 Turn the MENU knob to move the ► mark to LTC UB-MARKER.

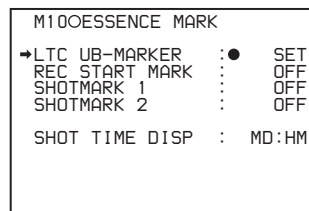

- 6 Push the MENU knob.

The ► mark to the left of LTC UB-MARKER changes to the ● mark, and the ● mark to the left of the setting changes to the ? mark.

- 7 Turn the MENU knob clockwise or counterclockwise until the desired setting appears.

The setting changes in the order of SET ↔ ALL ↔ OFF.

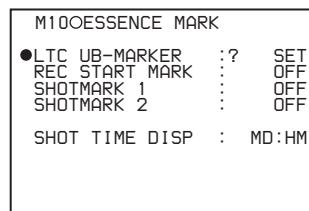

Item	Contents
SET	Determines whether to record REC START MARK, SHOT MARK 1, and SHOT MARK 2 in accordance with the ON/OFF setting for that item.
ALL	Records all of REC START MARK, SHOT MARK 1, and SHOT MARK 2.
OFF	Does not record any marks.

If you select SET, go to step 8.

If you select ALL or OFF, go to step 9.

- 8 Set the mark(s) to be recorded to ON.

- ① Turn the MENU knob to move the ► mark to the mark to be set.
- ② Turn the MENU knob clockwise or counterclockwise until the desired setting appears. To record the mark on the tape, select ON. To not record the mark, select OFF.
- ③ Perform settings for the remaining marks, repeating steps 1 and 2.

- 9 Set the MENU ON/OFF switch to OFF to end the menu operation.

Shot mark recording

When SHOT MARK 1 and SHOT MARK 2 are set to ON on the ESSENCE MARK page, good shot marks (shot mark 1 and shot mark 2) are recorded when you press the RET button of the lens. (If LTC UP-MARKER is set to OFF, the marks are recorded only in the system area. If LTC UP-MARKER is set to ALL, the marks are recorded in the LTC UBIT area even when SHOT MARK 1 and SHOT MARK 2 are set to OFF.)

To record a shot mark 1: Press the RET button on the lens once.

On the viewfinder screen, ● and the time code of the marked point are displayed for about 3 seconds.

To record a shot mark 2: Press the RET button on the lens twice.

On the viewfinder screen, X and the time code of the marked point are displayed for about 3 seconds.

For detailed information on shot mark operations, refer to the manual supplied with your VTR.

Note

When you perform the setting to confirm the image of the return video signal in the viewfinder (*see page 91*), shot mark 1 and shot mark 2 cannot be recorded by operating the RET button of the lens.

Recording start mark recording

When REC START MARK set to ON on the ESSENCE MARK page, a recording start mark is recorded at the beginning of recording. (If LTC UP-MARKER is set to OFF, the mark is recorded only in the system area. If LTC UP-MARKER is set to ALL, the mark is recorded in the LTC UBIT area even when REC START MARK is set to OFF.)

For detailed information on recording start mark operations, refer to the manual supplied with your VTR.

3-2-4 Starting a Shoot with a Few Seconds of Pre-Stored Picture Data (Picture Cache Function: with MSDW-903)

By installing the optional MSDW-903 extension board in the camcorder, the camcorder is able to constantly store a few seconds (up to 8 seconds) worth of the most current picture and sound data in the boards memory.

Thus, when you press the VTR START button or the VTR button on the lens, the recording starts with the data stored a few seconds before.

Setting the Picture Cache time/Picture Cache mode

To record in Picture Cache mode, you need to turn on Picture Cache mode and set the picture data storage time (Picture Cache time) using the USER menu.

The Picture Cache time and VTR SAVE/STBY switch settings determine the number of seconds of picture data that will be stored in memory and recorded when you press the VTR START button or VTR button on the lens.

The following table shows the approximate number of seconds worth of picture data (counting back from the time you begin recording) that will be recorded from memory. However, when changing from SAVE to STBY, or under the special situations explained in the notes on this page, the actual amount of data recorded may be shorter.

Picture Cache time setting and recording start point

Picture Cache time	Recording start point	
	VTR STBY mode	VTR SAVE mode
8 (seconds)	About 8 seconds before	About 4 seconds before
6 (seconds)	About 6 seconds before	About 4 seconds before
5 (seconds)	About 5 seconds before	About 4 seconds before
4 (seconds)	About 4 seconds before	About 4 seconds before
3 (seconds)	About 3 seconds before	About 3 seconds before
2 (seconds)	About 2 seconds before	About 2 seconds before
1 (seconds)	About 1 seconds before	About 1 seconds before
0 (seconds)	About 0 seconds before	About 0 seconds before

Notes

- After selecting the Picture Cache mode, immediately changing the Picture Cache time or performing playback or recording review, the picture data stored in memory before this operation are made to be unrecordable. This means that when you press the VTR START button or VTR button on the lens, the previously stored picture data will not be recorded.
- During playback or recording review, the picture data is not stored in the MSDW-903s memory. Picture data corresponding to the duration of playback or recording review will not be in memory and will not be recorded to tape.

Setting procedure

To turn Picture Cache mode on, proceed as follows:

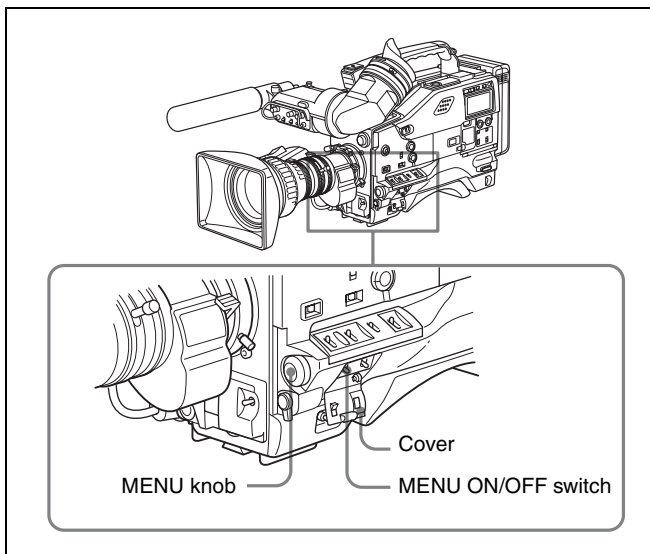

- 1 Set the MENU ON/OFF switch to ON.

The last accessed menu page appears on the viewfinder screen.

- 2 Turn the MENU knob until the FUNCTION 1 page appears.

When the question mark appears at the left corner of the title page, you can switch the pages. Turn the MENU knob clockwise or counterclockwise to display the desired page. The DF/NDF item on the FUNCTION 1 page appears only for the MSW-970.

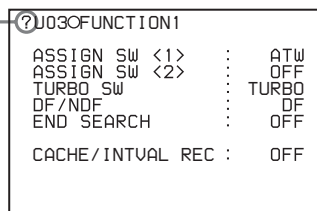

- 3 Press the MENU knob.

A \blacktriangleright mark appears on the left of the currently selected item and a \bullet mark appears on the left of the setting.

- 4 Turn the MENU knob to move the \blacktriangleright mark to "CACHE/INTVAL REC."

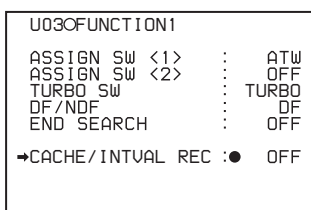

- 5 Press the MENU knob.

The \blacktriangleright mark on the left of "CACHE/INTVAL REC" changes to a \bullet mark and the \bullet mark on the left of the setting changes to a ? mark.

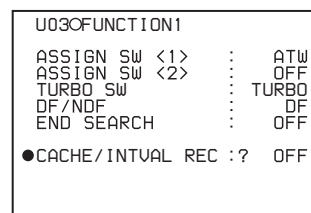

- 6 Turn the MENU knob until "CACHE" appears.

As you turn the MENU knob, the setting changes in the following sequence: OFF \leftrightarrow CACHE \leftrightarrow A. INT \leftrightarrow M. INT.

When "CACHE" appears, the camcorder is in Picture Cache mode, where picture, sound, and time code are constantly saved in memory. The TALLY indicator (green) in the viewfinder is on while picture data is being stored in memory.

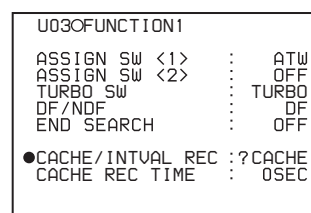

- 7 Press the MENU knob.

The \bullet mark on the left of "CACHE/INTVAL REC" changes to a \blacktriangleright mark and the ? mark on the left of the setting changes to a \bullet mark. In this case, you can select another item.

- 8 Turn the MENU knob to move the \blacktriangleright mark to "CACHE REC TIME."

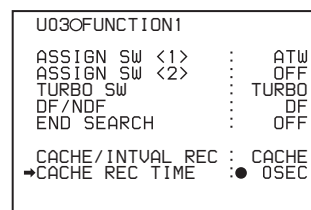

- 9 Press the MENU knob.

The \blacktriangleright mark on the left of "CACHE REC TIME" changes to a \bullet mark and the \bullet mark on the left of the setting changes to a ? mark.

- 10 Turn the MENU knob until the desired Picture Cache time appears.

As you turn the MENU knob, the Picture Cache time changes in the following sequence: 0SEC \leftrightarrow 1SEC \leftrightarrow 2SEC \leftrightarrow 3SEC \leftrightarrow 4SEC \leftrightarrow 5SEC \leftrightarrow 6SEC \leftrightarrow 8SEC.

11 Press the MENU knob.

The ● mark on the left of “CACHE REC TIME” changes to a ► mark and the ? mark changes to a ● mark.

12 To end the menu operation, set the MENU ON/OFF switch to OFF.

The menu disappears, and the display indicating the current status of the camcorder appears along the top and bottom of the viewfinder screen.

Settings made in Picture Cache mode are maintained until changed.

You can turn Picture Cache mode on and off by assigning the Picture Cache ON/OFF function to one of the assignable switches (ASSIGN 1/2 and TURBO GAIN), and pressing the switch.

For detailed information on the assignable switches, see “5-3-5 Assigning Functions to Assignable Switches” on page 95.

Notes

- You can change the Picture Cache mode menu settings while recording; any changes that you make, however, do not take effect until after the recording operation is completed.
- In Picture Cache mode, the internal time code generator operating mode is always F-RUN regardless of the setting of the F-RUN/SET/R-RUN switch.

Camcorder operations in Picture Cache mode

The recording procedure in Picture Cache time is basically the same as that for normal recording. However, note the following differences.

- When you record in Picture Cache mode, the picture you shoot is recorded to tape after the Picture Cache time elapses. For this reason, the tape does not stop immediately when you press the VTR START button. After the VTR START button is pressed, all tape operation buttons (EJECT, REW, F FWD, PLAY, and STOP) stop functioning until the Picture Cache time has elapsed. During this time, if you press the VTR START button or the VTR button on the lens, recording starts again as if there were no pause in recording.
- The time the tape stops after the VTR START button is pressed equals the Picture Cache time set. However, if you start recording within the set Picture Cache time immediately after selecting the Picture Cache mode, changing the Picture Cache time or performing playback or recording review, the picture data for the duration of the Picture Cache time will not be stored in memory. Thus, the time the tape stops after the STOP button is pressed becomes shorter than the Picture Cache time.
- The time code stops advancing while time data is being set (when the F-RUN/SET/R-RUN switch is set to SET).

For this reason, if you start recording immediately after switching to F-RUN or R-RUN (i.e., to a position other than SET), you may overwrite a portion of the previously recorded time code.

- Positions of essence marks, such as shot marks, may be shifted depending on the Picture Cache time setting.

When power is lost during recording

- When the power is turned off during recording, the camera will switch off by itself after the tape has run for a few seconds.
- If you remove the battery, pull out the DC cable, or cut power to the AC adaptor during recording, actual recording of picture data ends the instant the tape is stopped. However, a certain amount of recorded picture data, equal to that recorded during the Picture Cache time, will be lost, because it has not yet been recorded on the tape before the tape stops. For this reason, make sure you do not change the battery while recording.

When the tape runs out during recording

Please note that if the tape runs out and the camcorder stops during recording, a certain amount of recorded picture data, equal to that recorded during the Picture Cache time, will be lost, because it has not yet been recorded on the tape.

3-2-5 Shooting Picture at Intervals (Interval Rec Function: with MSDW-903)

Inserting an optional MSDW-903 extension board in the camcorder enables the camcorder to record pictures at various intervals. There are two kinds of Interval Rec mode:

Auto Interval Rec

In Auto Interval Rec mode, pictures are automatically shot a frame at a time at the specified interval and stored in memory. To use this function you must set the total time for shooting (TAKE TOTAL TIME) and the length of time for recording on the tape (REC TIME).

Manual Interval Rec

There are two modes of Manual Interval Rec:

- **Single Trigger mode**
Setting the number of frames to be recorded at one shooting (NUMBER OF FRAME) enables the camcorder to record the number of frames preset each time the VTR START button or the VTR button on the lens is pressed.
- **Continuous Trigger mode**
Pictures are automatically shot by preset frames at preset intervals by pressing the VTR START button or the VTR button on the lens.

In Auto Interval Rec and Continuous Trigger mode of Manual Interval Rec, by setting the PRE-LIGHTING function to ON, the light connected to the LIGHT connector automatically turns on before recording starts. This allows you to record pictures under stable light and color temperature conditions.

Auto Interval Rec mode settings

To make settings before shooting

To record in Auto Interval Rec mode, you need to turn on Auto Interval Rec and set the total time from start to finish of shooting (TAKE TOTAL TIME) and the length of time for recording on the tape (REC TIME), using the USER menu.

Notes

- To make settings for Auto Interval Rec mode, set “TAKE TOTAL TIME” first, then “REC TIME.”
- To turn on the light automatically before recording starts, set the LIGHT switch to AUTO.

To turn on Auto Interval Rec mode, proceed as follows:

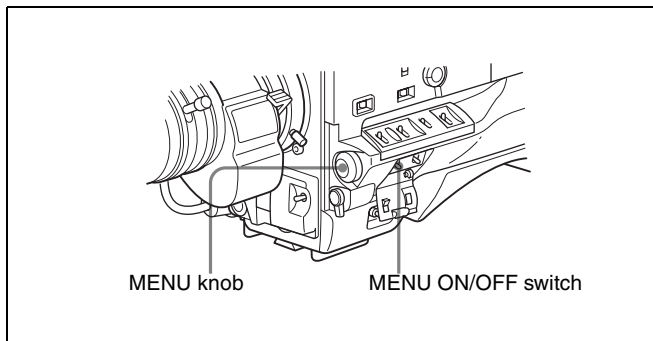

- 1 Set the MENU ON/OFF switch to ON.

The last accessed menu page appears on the viewfinder screen.

- 2 Turn the MENU knob until the FUNCTION 1 page appears.

When the question mark appears at the left corner of the title page, you can switch the pages. Turn the MENU knob clockwise or counterclockwise to display the desired page. The DF/NDF item on the FUNCTION 1 page appears only for the MSW-970.

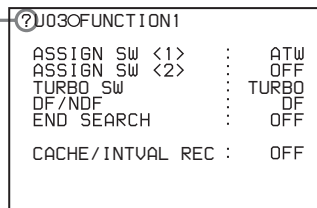

- 3 Press the MENU knob.

A ➔ mark appears on the left of the currently selected item and a ● mark appears on the left of the setting.

- 4 Turn the MENU knob to move the ➔ mark to “CACHE/INTVAL REC.”

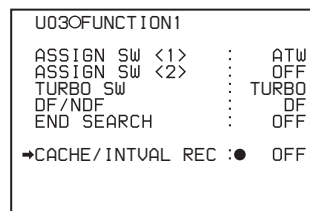

- 5 Press the MENU knob.

The ➔ mark on the left of “CACHE/INTVAL REC” changes to a ● mark and the ● mark on the left of the setting changes to a ? mark.

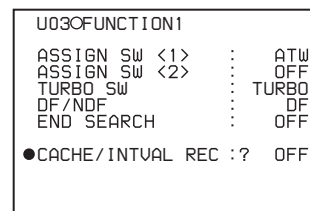

- 6 Turn the MENU knob until A. INT appears.

As you turn the MENU knob, the setting changes in the following sequence: OFF ↔ CACHE ↔ A. INT ↔ M. INT.

When A. INT appears, the camcorder is in Auto Interval Rec mode. The TALLY indicator (green) in the viewfinder flashes (one flash/second) while the camcorder is in this mode. Also, TAKE TOTAL TIME, REC TIME and PRE-LIGHTING appear.

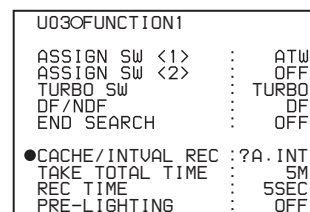

- 7 Press the MENU knob.

The ● mark on the left of “CACHE/INTVAL REC” changes to a ➔ mark and the ? mark of the setting changes to a ● mark.

- 8 Turn the MENU knob to move the ➔ mark to “TAKE TOTAL TIME.”

U030FUNCTION1			
ASSIGN SW <1>	:	ATW	:
ASSIGN SW <2>	:	OFF	:
TURBO SW	:	TURBO	:
DF/NDF	:	DF	:
END SEARCH	:	OFF	:
CACHE/INTVAL REC	:	?A. INT	:
→TAKE TOTAL TIME	:	5M	:
REC TIME	:	5SEC	:
PRE-LIGHTING	:	OFF	:

9 Press the MENU knob.

The ➔ mark on the left of “TAKE TOTAL TIME” changes to a ● mark and the ● mark on the left of the setting changes to a ? mark.

10 Turn the MENU knob until the desired setting of “TAKE TOTAL TIME” appears.

As you turn the MENU knob, the setting of TAKE TOTAL TIME changes in the following sequence:

5M ↔ 10M ↔ 15M ↔ 20M ↔ 30M ↔ 40M
 ↔ 50M ↔ 1H ↔ 2H ↔ 3H ↔ 4H ↔ 5H ↔
 7H ↔ 10H ↔ 15H ↔ 20H ↔ 30H ↔ 40H ↔
 50H ↔ 70H ↔ 100H.

Here M means minutes (5M is 5 minutes) and H means hours (1H is one hour).

11 Press the MENU knob.

The ● mark on the left of “TAKE TOTAL TIME” changes to a ➔ mark and the ? mark changes to a ● mark.

12 Turn the MENU knob to move the ➔ mark to “REC TIME.”

U030FUNCTION1			
ASSIGN SW <1>	:	ATW	:
ASSIGN SW <2>	:	OFF	:
TURBO SW	:	TURBO	:
DF/NDF	:	DF	:
END SEARCH	:	OFF	:
CACHE/INTVAL REC	:	?A. INT	:
TAKE TOTAL TIME	:	5M	:
→REC TIME	:	5SEC	:
PRE-LIGHTING	:	OFF	:

13 Press the MENU knob.

The ➔ mark on the left of “REC TIME” returns to a ● mark and the ● mark of the setting returns to a ? mark.

14 Turn the MENU knob until the desired time to be recorded on the tape appears.

As you turn the MENU knob, the setting of REC TIME changes in the following sequence:

5SEC ↔ 10SEC ↔ 15SEC ↔ 20SEC ↔ 30SEC
 ↔ 40SEC ↔ 50SEC ↔ 1MIN ↔ 2MIN ↔
58MIN ↔ 59MIN ↔ 60MIN.

Here SEC means seconds (5SEC is 5 seconds) and MIN means minutes (1MIN is one minute).

You cannot set a REC TIME that is more than one thirtieth of TAKE TOTAL TIME.

For example: When TAKE TOTAL TIME is set to 1H, the maximum value of REC TIME is 2 MIN. (60 minutes divided by 30 gives 2 minutes.)

The time setting displayed when you turn the MENU knob changes within the available setting times.

Be sure to set REC TIME after setting TAKE TOTAL TIME.

15 Press the MENU knob.

The ● mark on the left of “REC TIME” returns to a ➔ mark and the ? mark returns to a ● mark.

16 Turn the MENU knob to move the ➔ mark to “PRE-LIGHTING.”

U030FUNCTION1			
ASSIGN SW <1>	:	ATW	:
ASSIGN SW <2>	:	OFF	:
TURBO SW	:	TURBO	:
DF/NDF	:	DF	:
END SEARCH	:	OFF	:
CACHE/INTVAL REC	:	?A. INT	:
TAKE TOTAL TIME	:	5M	:
REC TIME	:	5SEC	:
→PRE-LIGHTING	:	OFF	:

17 Press the MENU knob.

The ➔ mark on the left of “PRE-LIGHTING” changes to a ● mark and the ● mark on the left of the setting changes to a ? mark.

18 Turn the MENU knob until the desired time to turn on the light before starting to record appears.

As you turn the MENU knob, the PRE-LIGHTING time changes in the following sequence: OFF ↔ 2SEC ↔ 5SEC ↔ 10SEC.

Notes

- Set the LIGHT switch on the camcorder to AUTO to turn on the light before recording. The light switch must also be set to ON. With these settings, the light turns on and off automatically. (However, the light remains on continuously if the off time is less than 5 seconds.)
- When the LIGHT switch is set to MANUAL and the light switch is set to ON, the light remains on continuously.

19 Press the MENU knob.

The ● mark on the left of “PRE-LIGHTING” returns to a ➔ mark and the ? mark returns to a ● mark.

20 To end the menu operation, set the MENU ON/OFF switch to OFF.

The menu disappears from the viewfinder screen and the message AUTO INTERVAL **M**S indicating Auto Interval Rec mode appears along the bottom of the viewfinder.

MS indicates the shooting interval. For example, when TAKE TOTAL TIME is set to 1H and REC TIME is set to 30 SEC, the message AUTO INTERVAL 00M04S appears. The shooting interval is 4 seconds.

The display indicating the current status of the camcorder appears along the top and bottom of the viewfinder.

Note

The settings for Auto Interval Rec mode are maintained until changed. However, if you switch off the camcorder power, Auto Interval Rec mode is cleared except for the TAKE TOTAL TIME, REC TIME and PRE-LIGHTING settings. To use the Auto Interval Rec function again after switching on the power, perform steps **1** to **6**.

Recording in Auto Interval Rec mode

Proceed as follows:

Note

When you use cassettes on which nothing is recorded, such as brand new cassettes, be sure to record color bars for more than 2 seconds at the beginning of a cassette.

- 1 After performing the basic procedures for shooting and recording, following the instructions in “3-2-1 Basic Procedures” (page 36), secure the camcorder so that it will not move.
- 2 Press the VTR START button on the camcorder or the VTR button on the lens.

The camcorder starts recording in Auto Interval Rec mode. When you use the PRE-LIGHTING function, recording starts after the light is switched on. The actual recording to disc begins when the camcorder has saved about five seconds of video in memory, so disc access is intermittent.

While recording in Auto Interval Rec mode, the TALLY indicator (green) in the viewfinder flashes (4 flashes/second) and the message “AUTO INTERVAL **M**S” flashes on the viewfinder screen.

When the camcorder is capturing the picture in memory, the REC indicator in the viewfinder lights. After the length of time for recording on the tape (REC TIME) has elapsed, the camcorder automatically stops recording.

To continue auto interval recording

Press the VTR START button on the camcorder or the VTR button on the lens again.

The camcorder starts recording in Auto Interval Rec mode again.

To interrupt auto interval recording

Press the VTR START button or the VTR button on the lens. The camcorder stops recording.

However, the tape may run for recording picture data already stored in memory.

To end auto interval recording

You can exit Auto Interval Rec mode using the following two methods:

- Set the POWER switch to OFF.
- Set CACHE/INTVAL REC to OFF on the FUNCTION 1 page.

Time required for shooting and time required for recording on the tape

Auto Interval Rec mode is effective for shooting objects that move very slowly. To use this function, you need to set the total time for shooting (TAKE TOTAL TIME) and the length of time for recording on the tape (REC TIME). The time required for shooting is the time required to capture the very slowly moving subject, and the camcorder must be arranged so that during this time the subject is always in the frame.

The tape recording time indicates the running time of the completed recording. The camcorder calculates the time-lapse interval from these two times.

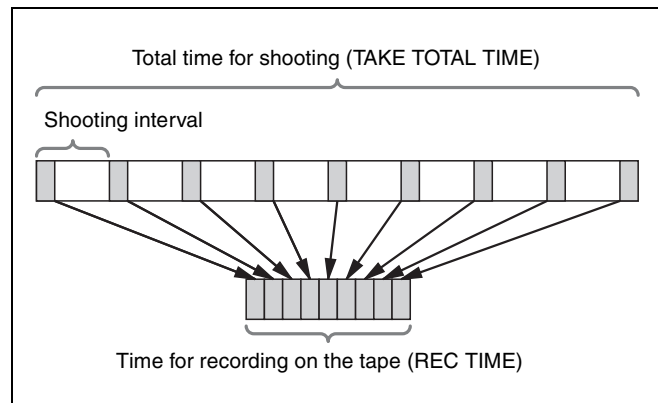

Notes on Auto Interval Rec operation

Note the following points.

Time code

In Auto Interval Rec mode, the internal time code generator runs in R-RUN mode regardless of how the F-RUN/SET/R-RUN switch is set.

The actual time of the shooting is saved in the user bits. When you need to set the internal clock, use the TIME DATE page of the DIAGNOSIS menu.

For details, see “5-3-6 Setting the Date/Time of the Internal Clock” on page 97.

Audio

Audio signals are not recorded in Auto Interval Rec mode.

Cassette control buttons

While recording in Auto Interval Rec mode, you cannot use the cassette control buttons (EJECT, REW, F FWD, PLAY and STOP). To use these buttons, stop recording by pressing the VTR START button or the VTR button on the lens.

Menu operation

While recording in Auto Interval Rec mode, you cannot change the settings of CACHE/INTVAL REC, TAKE TOTAL TIME and REC TIME. To change the settings, stop recording by pressing the VTR START button or the VTR button on the lens.

When the camcorder power is switched off during recording in Auto Interval Rec mode

- When you set the POWER switch to OFF, the camcorder will switch off by itself after the tape has run for a few seconds to record the picture data stored in memory.
- If you remove the battery, unplug the DC cable, or cut power to the AC adaptor during auto interval recording, picture data stored before recording stops (a maximum of 5 seconds) may be lost. Take care when changing the battery.

When tape runs out during auto interval recording

Note that picture data (a maximum of 5 seconds) shot and stored before the tape stops is not recorded if the tape runs out and the camcorder stops.

Manual Interval Rec mode

Manual Interval Rec has the following two modes.

Single Trigger mode: Each time the VTR START button or VTR button on the lens is pressed, the camcorder captures to memory a single shot consisting of the specified number of video frames.

Continuous Trigger mode: Once the VTR START button or VTR button on the lens is pressed, the camcorder captures consecutive shots to memory at the specified interval, with each shot consisting of the specified number of video frames.

Setting Single Trigger mode of Manual Interval Rec

Proceed as follows:

- 1 Carry out steps 1 to 5 of the procedure “*To make settings before shooting*” (page 44), to select CACHE/INTVAL REC on the FUNCTION 1 page.
- 2 Turn the MENU knob until “M. INT” appears.

U030FUNCTION1		
ASSIGN SW <1>	:	ATW
ASSIGN SW <2>	:	OFF
TURBO SW	:	TURBO
DF/NDF	:	DF
END SEARCH	:	OFF
●CACHE/INTVAL REC:?	:	M. INT
NUMBER OF FRAME	:	1
TRIGGER INTERVAL	:	5MIN
PRE-LIGHTING	:	OFF

As you turn the MENU knob, the setting changes in the following sequence: OFF ↔ CACHE ↔ A. INT ↔ M. INT.

When M. INT appears, the camcorder is in Manual Interval Rec mode and the TALLY indicator (green) in the viewfinder flashes. “NUMBER OF FRAME,” “TRIGGER INTERVAL” and “PRE-LIGHTING” appear.

- 3 Press the MENU knob.

The ● mark on the left of “CACHE/INTVAL REC” changes to a ➔ mark and the ? mark on the left of the setting changes to a ● mark.

- 4 Turn the MENU knob to move the ➔ mark to “NUMBER OF FRAME.”

U030FUNCTION1		
ASSIGN SW <1>	:	ATW
ASSIGN SW <2>	:	OFF
TURBO SW	:	TURBO
DF/NDF	:	DF
END SEARCH	:	OFF
CACHE/INTVAL REC:	:	M. INT
➔NUMBER OF FRAME	:	1
TRIGGER INTERVAL	:	5MIN
PRE-LIGHTING	:	OFF

- 5 Press the MENU knob.

The ➔ mark on the left of “NUMBER OF FRAME” changes to a ● mark, and the ● mark on the left of the setting changes to a ? mark.

- 6 Turn the MENU knob until the desired number of frames to be recorded in each shot appears.

As you turn the MENU knob, the number changes in the following sequence: 1 ↔ 2 ↔ 4 ↔ 8.

- 7 Press the MENU knob.

The ● mark on the left of “NUMBER OF FRAME” returns to a ➔ mark and the ? mark on the left of the setting returns to a ● mark.

- 8 Turn the MENU knob to move the ➔ mark to “TRIGGER INTERVAL.”

U030FUNCTION1			
ASSIGN SW <1>	:	ATW	
ASSIGN SW <2>	:	OFF	
TURBO SW	:	TURBO	
DF/NDP	:	DF	
END SEARCH	:	OFF	
CACHE/INTVAL REC	:	M. INT	
NUMBER OF FRAME	:	1	
→ TRIGGER INTERVAL	:	5MIN	
PRE-LIGHTING	:	OFF	

9 Press the MENU knob.

The → mark on the left of “TRIGGER INTERVAL” changes to a ● mark and the ● mark on the left of the setting changes to a ? mark.

10 Turn the MENU knob to display M.

U030FUNCTION1			
ASSIGN SW <1>	:	ATW	
ASSIGN SW <2>	:	OFF	
TURBO SW	:	TURBO	
DF/NDP	:	DF	
END SEARCH	:	OFF	
CACHE/INTVAL REC	:	M. INT	
NUMBER OF FRAME	:	1	
● TRIGGER INTERVAL:?	:	M	
PRE-LIGHTING	:	OFF	

If you turn the MENU knob clockwise or counterclockwise, the number changes in the following sequence: M ↔ 1SEC ↔ 2SEC.....12H ↔ 24H.

When M appears, the TALLY indicator (green) flashes (2 flashes/second) and PRE-LIGHTING disappears.

11 Press the MENU knob.

The ● mark on the left of “TRIGGER INTERVAL” returns to a → mark and the ? mark on the left of the setting returns to a ● mark.

12 To end the menu operation, set the MENU ON/OFF switch to OFF.

The menu disappears from the viewfinder screen and the message MANU INTERVAL *FRAME, indicating the single trigger mode of the Manual Interval Rec mode, appears along the bottom of the viewfinder. *FRAME indicates the number of frames set in step 6. The display indicating the current status of the camcorder appears along the top and bottom of the viewfinder.

Note

The settings for Single Trigger mode of Manual Interval Rec are maintained until changed. However, if you switch the camcorder power off, all Manual Interval Rec mode settings are cleared except for the NUMBER OF FRAME setting and the single trigger mode selection. To use Single Trigger mode of the Manual Interval Rec function again after switching on the power, perform steps 1 and 2.

Recording in Single Trigger mode of Manual Interval Rec

Follow the procedure below to shoot a picture in Single Trigger mode of Manual Interval Rec.

Note

When you use cassettes on which nothing is recorded, such as brand new cassettes, be sure to record color bars for more than 2 seconds at the beginning of a cassette.

1 After performing the basic procedure for shooting and recording following the instructions in “3-2-1 Basic Procedures” on page 36, secure the camcorder so that it will not move.

2 Push the VTR START button on the camcorder or the VTR button on the lens.

The camcorder starts recording in Single Trigger mode of Manual Interval Rec. The TALLY indicator (green) in the viewfinder flashes (2 flashes/second) and the message MANU INTERVAL *FRAME flashes on the viewfinder screen.

Each time you press the VTR START button or the VTR button, the camcorder captures and stores the picture data of the preset number of frames. The REC indicator in the viewfinder is on while the camcorder is capturing the picture in the memory. The camcorder stores picture data (about 5 seconds worth) in memory, and then actually records the stored picture data on the tape. The tape runs intermittently.

To stop recording in Single Trigger mode

You can stop recording in Single Trigger mode of Manual Interval Rec using the following two methods. However, the tape may continue to run to record the picture data stored in the memory at the instant the tape stopped.

- Press the EJECT button.
- Set the POWER switch to OFF.

Setting Continuous Trigger mode of Manual Interval Rec

1 Follow the procedure in steps 1 to 9 in “Setting Single Trigger mode of Manual Interval Rec” on page 47.

2 Turn the MENU knob clockwise or counterclockwise to display the desired trigger interval.

U030FUNCTION1			
ASSIGN SW <1>	:	ATW	
ASSIGN SW <2>	:	OFF	
TURBO SW	:	TURBO	
DF/NDP	:	DF	
END SEARCH	:	OFF	
CACHE/INTVAL REC	:	M. INT	
NUMBER OF FRAME	:	1	
● TRIGGER INTERVAL:?	:	1SEC	
PRE-LIGHTING	:	OFF	

If you turn the MENU knob clockwise or counterclockwise, the number changes in the following sequence: M ↔ 1SEC ↔ 2SEC ↔ 3SEC ↔ 4SEC ↔ 5SEC ↔ 6SEC ↔ 7SEC ↔ 8SEC ↔ 9SEC ↔ 10SEC ↔ 15SEC ↔ 20SEC ↔ 30SEC ↔ 40SEC ↔ 50SEC ↔ 1MIN ↔ 2MIN ↔ 3MIN ↔ 4MIN ↔ 5MIN ↔ 6MIN ↔ 7MIN ↔ 8MIN ↔ 9MIN ↔ 10MIN ↔ 15MIN ↔ 20MIN ↔ 30MIN ↔ 40MIN ↔ 50MIN ↔ 1H ↔ 2H ↔ 3H ↔ 4H ↔ 6H ↔ 12H ↔ 24H.

When a trigger interval time other than M is displayed, the camcorder is in Continuous Trigger mode of Manual Interval Rec. The TALLY indicator (green) flashes (1 flash/second).

3 Push the MENU knob.

The ? mark on the left of setting returns to a ● mark, and the ● mark on the left of “TRIGGER INTERVAL” returns to an ➔ mark.

4 Turn the MENU knob to move the ➔ mark to PRE-LIGHTING.

U03OFUNCTION1			
ASSIGN SW <1>	:	:	ATW
ASSIGN SW <2>	:	:	OFF
TURBO SW	:	:	TURBO
DF/NDF	:	:	DF
END SEARCH	:	:	OFF
CACHE/INTVAL REC	:	:	M. INT
NUMBER OF FRAME	:	:	1
TRIGGER INTERVAL	:	:	1SEC
➔PRE-LIGHTING	:	:	● OFF

5 Push the MENU knob.

The ➔ mark on the left of “PRE-LIGHTING” changes to a ● mark, and the ● mark on the left of the setting changes to a ? mark.

6 Turn the MENU knob clockwise or counterclockwise until the desired time interval at which to turn on the light before recording starts appears.

If you turn the MENU knob clockwise or counterclockwise, the PRE-LIGHTING time changes in the following sequence: OFF ↔ 2SEC ↔ 5SEC ↔ 10SEC.

Notes

- To turn on the light automatically before recording starts by setting the PRE-LIGHTING item to ON, be sure to set the LIGHT switch to AUTO. Also, set the switch of the light connected to the LIGHT connector to ON.

The light automatically turns on and off in Continuous Trigger mode of Manual Interval Rec. However, if the duration the light should be off is less than 5 seconds, the light is on continuously.

- When the LIGHT switch is set to MANUAL and the switch of the light is set to ON, the light is always on.

7 Push the MENU knob.

The ? mark on the left of setting returns to a ● mark and the ● mark on the left of PRE-LIGHTING returns to an ➔ mark.

8 To end the menu operation, set the MENU ON/OFF switch to OFF or close the cover of the menu operating section.

The menu disappears from the viewfinder screen and the message INTERVAL *SEC *FRAME, indicating Continuous Trigger mode of Manual Interval Rec, appears along the bottom of the viewfinder. *SEC indicates the trigger interval preset and *FRAME indicates the number of frames preset. The display indicating the current status of the camcorder appears along the top and bottom of the viewfinder.

Note

The settings for Continuous Trigger mode of Manual Interval Rec are maintained until changed. However, if you switch the camcorder power off, all Manual Interval Rec mode settings are cleared except for the NUMBER OF FRAME, TRIGGER INTERVAL, and PRE-LIGHTING settings. To use Continuous Trigger mode of Manual Interval Rec again after switching on the power, perform steps 1 and 2 in “Setting Single Trigger mode of Manual Interval Rec” on page 47.

Recording in Continuous Trigger mode of Manual Interval Rec

Follow the procedure below to shoot pictures in Continuous Trigger mode of Manual Interval Rec.

Note

When you use cassettes on which nothing is recorded, such as brand new cassettes, be sure to record color bars for more than 2 seconds at the beginning of a cassette.

- After performing the basic procedures for shooting and recording following the instructions in “3-2-1 Basic Procedures” on page 36, secure the camcorder so that it will not move.
- Push the VTR START button on the camcorder or the VTR button on the lens.

The camcorder starts recording in Continuous Trigger mode of Manual Interval Rec, and the flashing cycle of the TALLY indicator (green) changes from 1 flash/second to 4 flashes/second, and the message

INTERVAL *SEC *FRAME flashes on the viewfinder screen.

When you use the PRE-LIGHTING function, the light turns on when you press the VTR START button. After the preset PRE-LIGHTING time has elapsed, the camcorder captures the picture in the memory. The camcorder stores picture data (about 5 seconds worth) in memory, and then actually records the stored picture data on the tape. Thus, the tape runs intermittently. The REC indicator in the viewfinder is on while the camcorder is capturing the picture in the memory.

To stop recording in Continuous Trigger mode of Manual Interval Rec

You can stop recording in Continuous Trigger mode of Manual Interval Rec using the following two methods. However, the tape may continue to run to record the picture data stored in the memory at the instant the tape stopped.

- Press the VTR START button or the VTR button on the lens.
- Set the POWER switch to OFF.

Notes on Manual Interval Rec operation

Take note of the following points which are common to Single Trigger mode and Continuous Trigger mode. Differences are clearly noted, if any.

Time code

In Manual Interval Rec mode, the internal time code generator runs in R-RUN mode regardless of how the F-RUN/SET/R-RUN switch is set. Also, in Continuous Trigger mode of Manual Interval Rec, the actual time of the shooting is saved in the user bits.

Audio

Audio signals are not recorded in Manual Interval Rec mode.

Cassette control buttons

While recording in Single Trigger mode of Manual Interval Rec (the green TALLY indicator in the viewfinder flashes (2 flashes/second)), you cannot use the cassette control buttons (REW, F FWD, PLAY and STOP). Note that the camcorder stops recording in the single trigger mode of the Manual Interval Rec mode if you press the EJECT button.

While recording in Continuous Trigger mode of Manual Interval Rec (the TALLY indicator (green) flashes (4 flashes/second)), you cannot use the cassette control buttons (EJECT, REW, F FWD, PLAY and STOP). To stop recording, press the VTR START button or the VTR button on the lens. However, the tape may run to record the picture data stored in the memory before stopping the manual interval recording.

Menu operation

In Single Trigger mode of Manual Interval Rec, you cannot change the settings of “CACHE/INTVAL REC” and

“NUMBER OF FRAME” on the FUNCTION 1 page after the camcorder starts recording. To change the settings, stop recording by pressing the EJECT button or setting the POWER switch to OFF.

While recording in Continuous Trigger mode of Manual Interval Rec, you cannot change the settings of CACHE/INTVAL REC, NUMBER OF FRAME and TRIGGER INTERVAL on the FUNCTION 1 page. To change these settings, stop recording by pressing the VTR START button or the VTR button on the lens or by setting the POWER switch to OFF.

When the camcorder power is switched off during recording in Manual Interval Rec mode

- When you set the POWER switch to OFF, the camcorder will switch off by itself after disc access has continued for a few seconds to record the picture data stored in memory.
- If you remove the battery, unplug the DC cable, or cut the power to the AC adaptor during manual interval recording, picture data stored before recording stops (a maximum of 10 seconds) may be lost. Take care when changing the battery.

When tape runs out during recording in Manual Interval Rec mode

Note that picture data (a maximum of 5 seconds) at the instant the tape stopped is not recorded if the tape runs out and the camcorder stops.

3-2-6 Continuous Recording on Previous Cut

By assigning the RE-TAKE function to the ASSIGN 1 switch, you can use the ASSIGN 1 switch to position the tape at the most recent cut, clear it and record the new cut.

For detailed information, see “5-3-5 Assigning Functions to Assignable Switches” on page 95.

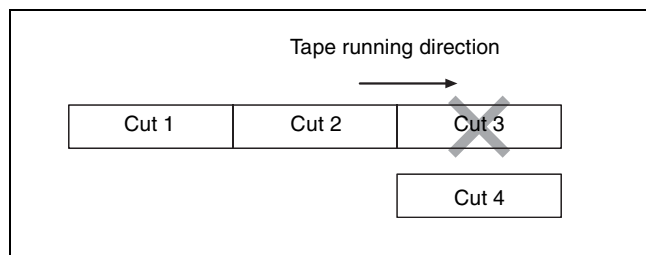

Example: After recording cut 3, clearing cut 3 and recording cut 4 after cut 2

Continuous recording the new cut after the cut before the most recent cut

In the above example, with the camcorder in the recording pause mode after recording the cut 3, press the RET switch on the lens while holding the ASSIGN 1 switch down.

The camcorder automatically positions the tape at the end point of cut 2 and turns in the recording pause mode.

Record cut 4.

Cut 4 is recorded after cut 2.

Notes

- When pictures consisting of cuts recorded using the RE-TAKE function are played back on a VTR for professional use, the CHANNEL CONDITION indicator, which indicates the condition of the played back signal of the VTR, may be lit in yellow, or the previously recorded timecode may be displayed for a few seconds. To avoid this, it is recommended that you make the first part of the cut (in the above example, cut 4) about 3 seconds longer.
- In the following cases, the RE-TAKE function is not accepted. The message “INVALID OPERATION!” is displayed on the viewfinder screen for three seconds. (The message is not displayed if the DISP VIDEO RATE setting of the MAINTENANCE menu is not ON.)
 1. When only one cut has been recorded
 2. When the length of the recorded cuts is less than three seconds
 3. When Picture Cache is ONThe RE-TAKE function is also not accepted after recording stops until the recording pause operation is completed (about 1 second). The message “INVALID OPERATION!” is displayed. In this case, the RE-TAKE function will be accepted when you perform the RE-TAKE operation again after the message disappears.

3-2-7 Searching for the Last Recorded Portion and Turning in Recording Pause Mode (End Search Function)

The End Search function allows the camcorder to search for the end of the recording on the tape after the recorded portion is rewound and played back.

To use this function, set the END SEARCH function to ON on the FUNCTION 1 page of the USER menu.

For detailed information on menu operation, see “5-1-2 Basic Menu Operations” on page 76.

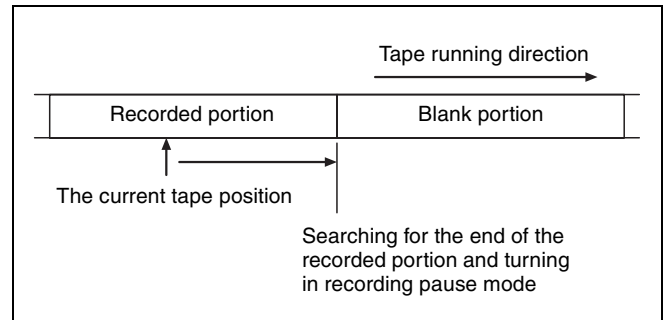

END SEARCH function

Searching for the end of the recording and turning in recording pause mode

To start the recording again after rewinding the recorded tape, playing it back and stopping the camcorder, follow the procedure.

Press the RET button on the lens.

The tape automatically runs and stops at the end of the recording. The camcorder is in recording pause mode.

Note

When the STOP KEY FREEZE function is set to become active on the VTR MODE page of the MAINTENANCE menu, the picture is frozen once you push the STOP button during playback. To activate the end search function, push the STOP button again to stop the camcorder and then press the RET button on the lens.

3-3 Checking Recording and Playback

By pressing the PLAY button, you can review any length of recording in the viewfinder in black and white. There are two other ways to review the recording.

- **Recording review:** You can view the last 2 seconds of the recording in the viewfinder in black and white.
- **Color playback:** You can see the recording in color on a color video monitor without the need for any external adaptor.

You may also view the picture during searching by rewinding or fast forwarding by pressing the PLAY + REW button or PLAY + F FWD button.

See “2-3 Audio Functions” on page 18 for information about the switches and controls used to select the audio output signal and to adjust the audio level.

3-3-1 Checking the Last Two Seconds of the Recording — Recording Review

If you press the RET button on the lens while recording is paused, the last two seconds of the recording is played back on the viewfinder screen and the color LCD. Use this function to check whether recording went smoothly. If you hold the RET button down longer, at most 10 seconds of the tape is rewind and played back. After playback, the camcorder is ready to start recording again.

By assigning the LENS RET function to the ASSIGN 1 switch, you can use the ASSIGN 1 switch in the same way as the RET button on the lens.

For details, see “5-3-5 Assigning Functions to Assignable Switches” on page 95.

Note

The recording review functions only works if the recording you have made is at least 3 seconds long.

3-3-2 Checking the Recording on the Color Video Monitor — Playback in Color

Connect a color video monitor to the VIDEO OUT connector of the camcorder. By pressing the PLAY button, you can view the recorded picture.

When the optional CBK-SD01 SDI Output Board is installed, you can connect a color video monitor provided with an SDI IN connector.

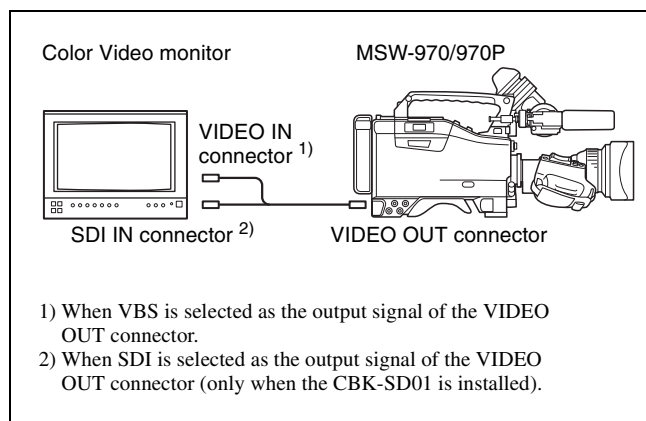

Color playback

Notes

- You can select either VBS or SDI as the output signal of the VIDEO OUT connector when the CBK-SD01 is installed.
- When the CBK-SD01 is not installed, the OUTPUT SEL page is not displayed. The output is fixed to VBS.

For details, see “5-3-2 Selecting the Output Signals” on page 93.

3-4 Tele-File System

3-4-1 Recording the Recording Start Time Code onto the Memory Label

The VTR section is compatible with the Tele-File memory label system.

This system allows you to record the recording start time code, model name, serial No. and TAPE format onto the MLB-1M-100 memory label (not supplied). This is very helpful for management of the cassette tapes and to improve the efficiency of the tape editing.

The memory label attached to the cassette is automatically detected.

Recording the recording start time code onto the memory label

Follow the procedure below to record the recording start time code.

- 1 Insert the cassette onto which the MLB-1M-100 memory label has been attached.

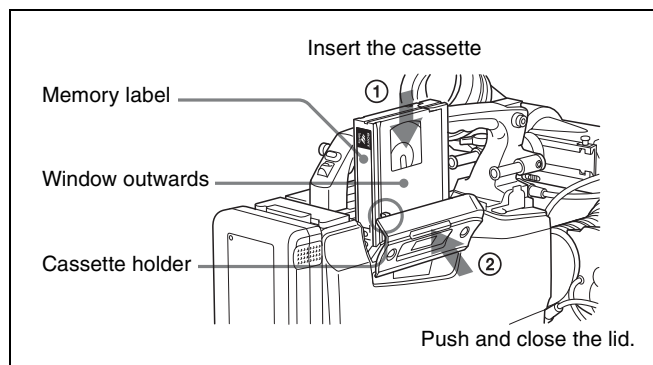

- 2 Press the VTR START button or the VTR button on the lens.

At the instant the recording starts, the time code of the recording start is recorded on the memory label.

Confirming the remaining capacity on the memory label

- 1 Set the MENU ON/OFF switch to ON while pushing the MENU knob.

The TOP menu appears.

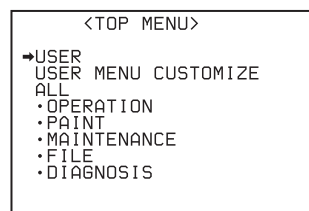

- 2 Turn the MENU knob to move -> mark to FILE.

- 3 Push the MENU knob.

When the FILE menu is first used, the CONTENTS page of the FILE menu appears.

Or if you used the FILE menu already, the page that was on the screen when the last FILE menu operation ended appears on the viewfinder screen.

- 4 When the CONTENTS page is displayed, turn the MENU knob to move -> mark to TELE FILE, then push the MENU knob.

When any page of the FILE menu is displayed, turn the MENU knob until the TELE FILE page appears, then push the MENU knob.

TELE FILE page

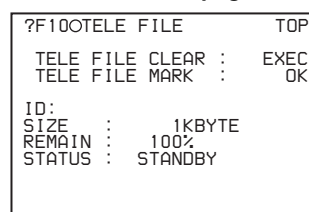

The remaining capacity of the memory label is displayed at the REMAIN column.

You can record the recording start time code about 130 times on the memory label of 1 Kilobyte.

Note

When the remaining capacity of the memory label becomes 0%, you can not record the recording start time code any more.

0% is displayed at the REMAIN column and the message “MEMORY FULL” is displayed at the STATUS column.

Warnings on the viewfinder screen when the remaining capacity is 0%

In the following cases, the message “TELE FILE MEMORY FULL” is displayed at the setting change and adjustment progress message display area of the viewfinder.

- When loading the cassette onto which the memory label whose memory capacity is 0% is attached.
- When loading the cassette onto which the memory label whose memory capacity is 0% is attached and starting / stopping the recording.

Clearing recorded data

- 1 Follow steps 1 to 4 in “Confirming the remaining capacity on the memory label” (page 53) until the TELE FILE page of the FILE menu is displayed on the viewfinder screen.

```
?F100TELE FILE      TOP
TELE FILE CLEAR :   EXEC
TELE FILE MARK  :     OK

ID:
SIZE   :           1KBYTE
REMAIN :           100%
STATUS :     STANDBY
```

- 2 Turn the MENU knob to move \blacktriangleright mark to TELE FILE CLEAR, then push the MENU knob.

```
F100TELE FILE      TOP
  CLEAR OK?       YES  $\blacktriangleright$  NO
 $\blacktriangleright$ TELE FILE CLEAR :  $\square$  EXEC
TELE FILE MARK  :     OK

ID:
SIZE   :           1KBYTE
REMAIN :           100%
STATUS :     STANDBY
```

The message CLEAR OK? YES NO appears. In this case, the \blacktriangleright mark is displayed for NO and NO flashes.

- 3 Turn the MENU knob to move \blacktriangleright mark to YES (YES flashes), then push the MENU knob.

The data recorded on the memory label is cleared. “100%” appears at the REMAIN column.

Notes

- When the memory label is protected from accidental erasure, you cannot clear recorded data.
- The time code data is cleared. However, the memory label ID is not cleared.

3-4-2 Recording a Tele-File Mark

The Tele-File mark, that is a rating of the images recorded just before they are recorded, can be recorded onto the memory label with the recording start time code, every time the unit enter the rec pause mode.

The following three kinds of Tele-File marks are available:

- **OK:** Place this mark when you decide the recorded images are good.
- **NG:** Place this mark when you decide the recorded images are not good.
- **KP:** Place this mark when it is hard to decide whether or not the recorded images are good just after recording, or when you want to insert a mark between multiple shots.

Recorded Tele-File marks are read by studio-use devices, logging software, and so on, which support the Tele-File function. These marks are very helpful for improving the efficiency of tape editing.

Note

To use this function, the TELE-FILE MARK function should be assigned to the ASSIGN 1 switch.

For details, see “5-3-5 Assigning Functions to Assignable Switches” on page 95.

Recording a Tele-File mark (OK/NG/KP) onto the memory label

Follow the procedure below to record Tele-File marks while shooting.

- 1 Start recording and set the unit to rec pause mode by pushing the VTR START button or the VTR button on the lens.
- 2 Push the ASSIGN 1 switch and select the appropriate mark from among OK, NG, KP or ERASE.

Push the ASSIGN 1 switch several times until the appropriate marks appears on the viewfinder. When the display disappears from the viewfinder, the selected mark is recorded with the recording start time and one of the following messages appears on the viewfinder.

Message	Meaning
TELE-FILE MARK: OK	States that an OK mark has been recorded.
TELE-FILE MARK: NG	States that an NG mark has been recorded.
TELE-FILE MARK: KP	States that a KP mark has been recorded.
TELE-FILE MARK: ERASE	States that a Tele-File mark recorded on that shot has been cancelled.

If the display disappears before you selected the appropriate mark

Repeat pushing the ASSIGN 1 switch until the desired mark appears. If the desired mark disappears from the viewfinder while that mark is displayed, the mark recorded before will be overwritten and the mark newly displayed is recorded.

Note

The Tele-File marks are recorded only when they are recorded using the ASSIGN 1 switch to which this function is applied.

If you perform normal operations for starting recording and entering in rec pause mode, the unit activates the

operation explained in “3-4-1 Recording the Recording Start Time Code onto the Memory Label” on page 53. The Tele-File marks can be added only to the shot recorded just before entering the rec pause mode.

Warning/error messages

When Tele-File marks cannot be recorded correctly or may not be recorded, the following messages appear.

Warning message

TELE-FILE NEAR FULL!: This message appears when the remaining capacity of the memory label nears about 5% or less, but Tele-File marks are still correctly recorded.

Error messages

When Tele-File marks cannot be recorded due to mis-operation or memory label problems.

NO TELE-FILE!: A cassette tape without a memory label has been loaded.

TELE-FILE FULL!: The memory label on the cassette tape is full.

TELE-FILE WRITE PROTECT!: The memory label is write-protected.

Message related to mis-operation

INVALID OPERATION: The message appears when you push the ASSIGN 1 switch before you start recording. The operation is invalid.

Confirming the remaining capacity on the memory label and clearing recorded data

For detailed information, see “Confirming the remaining capacity on the memory label” (page 53) and “Clearing recorded data” (page 54) in “3-4-1 Recording the Recording Start Time Code onto the Memory Label”.

3-5 Recording Video Signals from External Equipment (When Using an MSDW-904)

Inserting the optional MSDW-904 extension board in the camcorder enables the camcorder to record analog composite video signals from external equipment connected to the GENLOCK IN connector.

Selecting the signals to be recorded

You can select which signals you will record, pictures being shot by the camcorder or video signals from the external equipment connected to the GENLOCK IN connector, using the SOURCE SEL page of the OPERATION menu.

When the REC VIDEO SOURCE function is assigned to the ASSIGN 2 switch, you can switch the signal to be recorded, regardless of the setting on the SOURCE SEL page of the OPERATION menu.

Note

You can switch the signals to be recorded at any time while recording on the tape. However, the signals recorded at the point where the signal is switched may be distorted.

Proceed as follows:

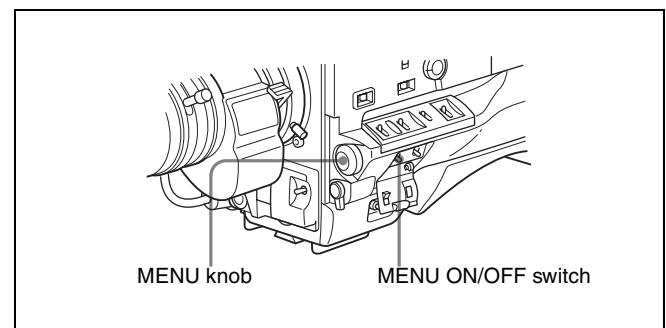

- 1 Holding down the MENU knob, set the MENU ON/OFF switch to ON.

The TOP menu appears.

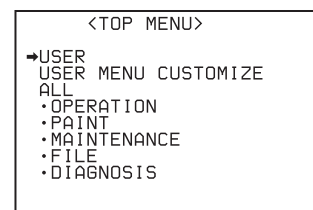

2 Turn the MENU knob to move the ➔ mark to “OPERATION.”

3 Press the MENU knob.

If this is the first time the OPERATION menu has been displayed, the CONTENTS page of the OPERATION menu appears. If the menu has been used before, the last accessed page appears.

4 If the CONTENTS page is displayed, turn the MENU knob to move the ➔ mark to “SOURCE SEL,” and press the MENU knob.

If a different page is displayed, turn the MENU knob until the SOURCE SEL page appears, then press the MENU knob to select the page.

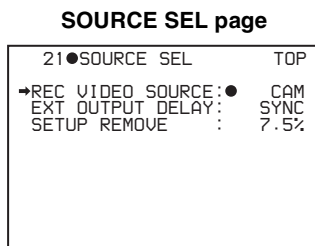

(“SETUP REMOVE” is displayed only when “UC/J SELECT” on the FORMAT page is set to “J” on the MSW-970.)

5 Turn the MENU knob to move the ➔ mark to “REC VIDEO SOURCE,” then press the MENU knob.

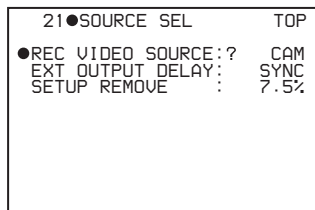

The ➔ mark on the left of “REC VIDEO SOURCE” changes to a ● mark and the ● mark on the left of the setting changes to a ? mark.

Item	Description
CAM	Records the pictures being shot by the camcorder.
EXT	Records video signals from the external equipment connected to the GENLOCK IN connector (with MSDW-904).

6 Turn the MENU knob to display “EXT.”

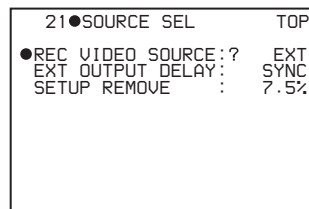

7 Press the MENU knob.

The ● mark on the left of “REC VIDEO SOURCE” returns to a ➔ mark and the ? mark on the left of the setting returns to a ● mark.

8 To end menu operations, set the MENU ON/OFF switch to OFF.

The menu disappears from the viewfinder screen, and the display indicating the current status of the camcorder appears along the top and bottom of the screen.

While recording in EXT mode, EXT is displayed along the top of the viewfinder screen.

Notes

- Even when EXT is selected for REC VIDEO SOURCE, if the external video signal is not input to the GENLOCK IN connector, the camcorder does not change to EXT mode, and the pictures being shot by the camcorder are recorded on the tape.
- Even if GENLOCK ON/OFF is set to OFF on the GENLOCK page of the MAINTENANCE menu, the camcorder is automatically synchronized with the external reference video signal when the external video signal is input to the GENLOCK IN connector in EXT mode. When the setting is switched to CAM mode, or when no signals are input to the GENLOCK IN connector even in EXT mode, the camcorder is reset to the original setting.

Selecting the delay mode of the vertical synchronizing (V sync) signal of the output video signal

In EXT mode, the video signal output from the TEST OUT connector or the VIDEO OUT connector is output with a delay of 8 horizontal lines against the external input signal, because the input signals, including the V sync signal, undergo digital processing internally.

There will not be any problems when you see the pictures of the output video signals on the monitor. However, if you want to output the V sync signals that are at the same position as the V sync signals of the external signal, use the menu to select the appropriate V sync delay.

1 Follow steps 1 to 4 in “Selecting the signals to be recorded” (page 55) until the SOURCE SEL page of

the OPERATION menu is displayed on the viewfinder screen.

- Turn the MENU knob to move the ➔ mark to EXT OUTPUT DELAY, then push the MENU knob.

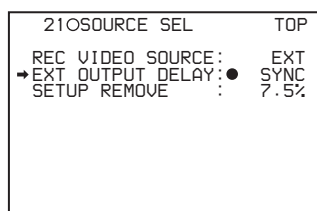

The ➔ mark on the left of “EXT OUTPUT DELAY” changes to the ● mark, and the ● mark to the left of the setting changes to the ? mark.

Item	Contents
SYNC	Outputs the video signals including the V sync signal, which are delayed by 8 horizontal lines against the input signals to the GENLOCK IN connector, from the TEST OUT connector or the VIDEO OUT connector. The pictures are displayed at the correct position on the video monitor. ¹⁾
VIDEO	Outputs the video signals, excluding the V sync signal, with delayed by 8 horizontal lines against the input signals to the GENLOCK IN connector, from the TEST OUT connector or the VIDEO OUT connector. The V sync signal is the same as the V sync signal input to the GENLOCK IN connector. On the video monitor, pictures are displayed lowered by 8 horizontal lines. ²⁾

- Since the V sync signal is output with delay of 8 horizontal lines, any external equipment connected after the second one are not synchronized with the camcorder when interconnecting multiple camcorders for recording.
- Even though the pictures are displayed at lower position on the monitor, the video signals are correctly recorded on the tape.

- Turn the MENU knob until the desired delay mode appears.
- Push the MENU knob.

The ● mark on the left of “EXT OUTPUT DELAY” returns to the ➔ mark and the ? mark to the left of the setting returns to the ● mark.

- To end menu operations, set the MENU ON/OFF switch to OFF.

The menu disappears from the viewfinder screen, and the display indicating the current status of the camcorder appears along the top and bottom of the viewfinder screen.

Removing the setup signal from the external video signals (MSW-970 only)

When the UC/J SELECT item is set to UC on the FORMAT page of the OPERATION menu, the SETUP REMOVE item appears on the SOURCE SEL page of the USER menu.

The SETUP REMOVE item allows you to eliminate the setup signal from the external video signals within a range of from 0 to 10% in 0.5% steps. The elimination range has been set to 7.5% at the factory.

Notes

- When the UC/J SELECT item is set to UC on the FORMAT page of the OPERATION menu, a 7.5% setup signal is automatically added to the composite video signal output from the TEST OUT connector.
- Even when the GENLOCK ON/OFF item is set to “OFF” on the GENLOCK page of the MAINTENANCE menu, the camcorder is automatically synchronized with the external reference video signal when the external video signal is input to the GENLOCK IN connector in EXT mode. When the setting is switched to CAM mode, or when no signals are input to the GENLOCK IN connector even in EXT mode, the camcorder is reset to the original setting.

3-6 Freezing a Picture During Playback

Pressing the STOP button during playback stops playback and freezes the picture.

The VTR MODE page of the MAINTENANCE menu allows you to set the freeze-frame mode where you can view the frozen picture during playback.

Performing the settings required for freezing the picture

- 1 Follow steps 1 to 4 in “Settings for recording essence marks to the system area” (page 38) to display the VTR MODE page of the MAINTENANCE menu.

```
?M080VTR MODE
REC TALLY BLINK : ON
REC START BEEP : OFF
LCD DISPLAY HOLD: TIMER
LCD HOLD TIMER : 1H
REC VIDEO RATE : 50M
STBY OFF TIMER : 60MIN
STOP KEY FREEZE : OFF
```

- 2 Turn the MENU knob to move the ➔ mark to STOP KEY FREEZE, then push the MENU knob.

```
M080VTR MODE
REC TALLY BLINK : ON
REC START BEEP : OFF
LCD DISPLAY HOLD: TIMER
LCD HOLD TIMER : 1H
REC VIDEO RATE : 50M
STBY OFF TIMER : 60MIN
➔STOP KEY FREEZE : ● OFF
```

The ➔ mark on the left of STOP KEY FREEZE changes to a ● mark, and the ● mark on the left of the setting changes to a ? mark.

- 3 Turn the MENU knob clockwise or counterclockwise until the desired freeze mode appears.

The freeze mode changes in the following sequence:
OFF ↔ FRAME ↔ FIELD

Setting	Contents
OFF	Deactivates the freeze function.
FRAME	Freezes pictures in frame mode. This mode is effective for freezing pictures of objects that are not moving.
FIELD	Freezes pictures in field mode. This mode is effective for freezing moving pictures.

- 4 Push the MENU knob.

The ? mark on the left of the setting returns to a ● mark, and the ● mark on the left of STOP KEY FREEZE returns to an ➔ mark.

- 5 To end menu operation, set the MENU ON/OFF switch to OFF.

Viewing frozen pictures

- 1 Push the PLAY button to start playback.
- 2 Push the STOP button at the instant when you want to freeze the picture.

The tape stops running and the picture is frozen. The time code is displayed in the counter display and the PLAY indicator flashes (one flash/second).

Changing to another mode

To cancel the freeze-frame mode for viewing the frozen picture and change to another mode, proceed as follows:

To restart playback: Push the PLAY button.

To view the pictures shot by the camcorder: Push the STOP button.

To rewind the tape: Push the REW button.

To fast forward the tape: Push the F FWD button.

To eject the tape: Push the EJECT button.

Notes

- In the freeze-frame mode, you cannot start recording pictures on the tape. To start recording the shot pictures again, push the STOP button to finish playback and then push the VTR START button.
- When changing to the recording pause mode from the freeze-frame mode by using the end-search function or positioning function for continuous recording, push the STOP button first, and then push the RET button.

When remotely controlling the camcorder from an RM-B150/B750 remote control unit (not supplied)

You can perform the same operation from an RM-B150/B750.

3-7 Setting the Stand-by off Timer During Rec-Pause

The VTR SAVE/STBY switch allows you to control the VTR power mode during pauses in recording (rec-pause) or when stopped.

However, even in the standby mode (with the VTR SAVE/STBY switch set to STBY), you can set the VTR in such a way that the mode is automatically switched from the standby mode to save mode when the tape does not run for a preset time, using the VTR MODE page of the MAINTENANCE menu.

- 1 Follow steps 1 to 4 in “Settings for recording essence marks to the system area” (page 38) to display the VTR MODE page of the MAINTENANCE menu.
- 2 Turn the MENU knob to move the \blacktriangleright mark to STBY OFF TIMER, then push the MENU knob.

```

MOBOVTR MODE
REC TALLY BLINK : ON
REC START BEEP : OFF
LCD DISPLAY HOLD : TIMER
LCD HOLD TIMER : 1H
REC VIDEO RATE : 50M
- STBY OFF TIMER : ● 60MIN
STOP KEY FREEZE : OFF
  
```

The \blacktriangleright mark on the left of “STBY OFF TIMER” changes to a ● mark, and the ● mark on the left of the setting changes to a ? mark.

- 3 Turn the MENU knob clockwise or counterclockwise until the desired STBY OFF TIMER appears.

If you turn the MENU knob clockwise or counterclockwise, STBY OFF TIMER changes in the following sequence: 60MIN \leftrightarrow 30MIN \leftrightarrow 10MIN \leftrightarrow 5MIN \leftrightarrow OFF.

In order not to enter in the VTR SAVE mode, select OFF.

To enter the VTR SAVE mode, select the desired time.

- 4 Press the MENU knob.

The ● mark on the left of “STBY OFF TIMER” returns to an \blacktriangleright mark, and the ? mark to the left of the setting returns to the ● mark.

- 5 To end menu operations, set the MENU ON/OFF switch to OFF.

4-1 Adjusting the Black Balance and the White Balance

To ensure excellent image quality when using this camcorder, conditions may require that both the black balance and the white balance be adjusted.

Black balance adjustment

The black balance will require adjustment in the following cases.

- When the camcorder is used for the first time
- When the camcorder has not been used for a long time
- When the camcorder is used under conditions in which the surrounding temperature has changed greatly
- When the GAIN selector (L/M/H) values have been changed by using the USER menu

It is not usually necessary to adjust the black balance when using the camcorder after it has been off.

White balance adjustment

Always readjust the white balance when the lighting conditions change.

Viewfinder screen displays

If the black balance or white balance adjustment is started, messages that report on the progress and results are displayed on the viewfinder screen when the VF DISP MODE item is set to “2” or “3” on the VF DISP 1 page of the USER menu.

Note

Black balance and white balance adjustment values that are automatically set by the camcorder and the various settings are stored in the camcorder memory and retained even when the power is turned off.

4-1-1 Adjusting the Black Balance

To automatically adjust the black balance

In automatic black balance mode, adjustments are performed in the following order: clamp level, black set, and black balance. Manual black balance adjustment can be selected from the setup menu.

Note that the automatic black balance adjustment includes a function to correct for white flecks caused in the CCDs by cosmic rays, in addition to the normal black balance operation.

To adjust the black balance, proceed as follows:

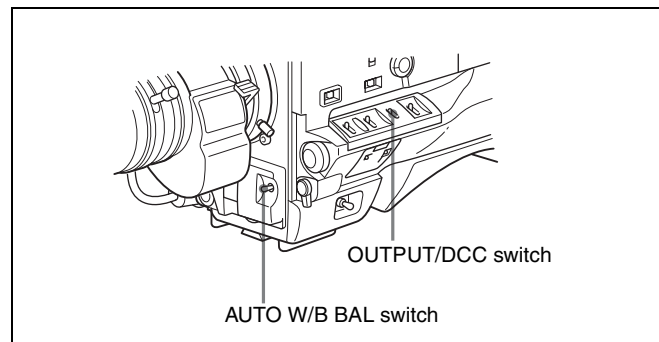

- 1 Set the OUTPUT/DCC switch to CAM.
- 2 Push the AUTO W/B BAL switch to BLK and release the switch.

The switch returns to the center position, and the adjustment is executed.

During adjustment, the following message is displayed on the viewfinder screen.

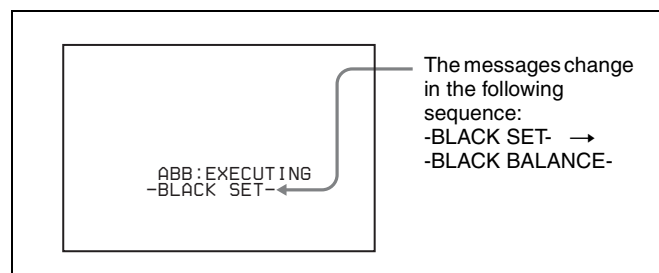

The black balance adjustment ends in a few seconds with the message “ABB:OK” and the adjustment value is automatically stored in memory.

Notes

- During the black balance adjustment, the iris is automatically closed.
- During the black balance adjustment, the gain selection circuit is automatically activated so you may see flickering on the viewfinder screen, but this is not a fault.

If automatic black balance adjustment cannot be made

If the black balance adjustment cannot be completed normally, an error message will appear for about 3 seconds on the viewfinder screen (in display mode 2 or 3). Possible messages are listed below.

Black balance adjustment error messages

Error message	Meaning
ABB : NG IRIS NOT CLOSED	The lens iris did not close; adjustment was impossible.
ABB : NG TIME LIMIT	Adjustment could not be completed within the standard number of attempts.
ABB : NG R (or G or B) : OVERFLOW	The difference between the reference value and the current value is so great that it exceeds the range. Adjustment was impossible.

If any of the above error messages is displayed, retry the black balance adjustment.

Keep pushing the AUTO W/B BAL to BLK until “-BLACK SET-” appears after “-BLACK BALANCE-” appears. If the error message occurs again, contact your Sony service representative.

Note

If the lens cable is not firmly connected to the LENS connector, it may not be possible to adjust the lens iris. If this happens, the black balance will be incorrect.

Black balance memory

Values stored in memory are held until the black balance is next adjusted.

4-1-2 Adjusting the White Balance

To automatically adjust the white balance

When you make automatic white balance adjustment, the adjustment value obtained is saved in memory.

Proceed as follows:

- 1 Set the switches and selectors as shown in the figure below.

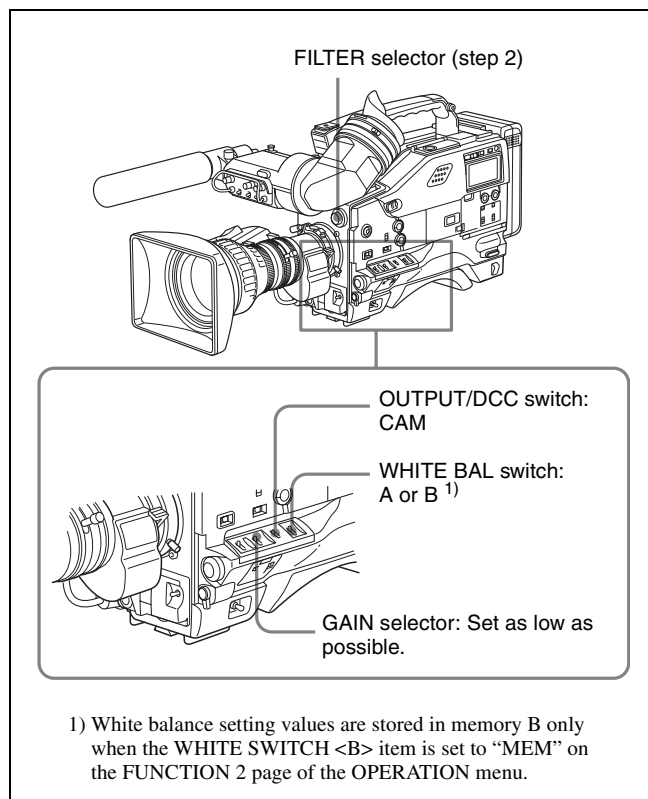

If the setting of the GAIN selector or WHITE BAL switch is changed, a message reporting the new setting position appears for about 3 seconds in the setting change and adjustment progress message display area of the viewfinder screen.

- 2 Set the FILTER selector to suit the lighting conditions as follows:

FILTER selector (outer knob) setting and CC-filter selection

FILTER selector (outer knob) setting	CC filter
A	Cross filter
B	3200K
C	4300K
D	6300K

FILTER selector (inner knob) setting and ND-filter selection

FILTER selector (inner knob) setting	ND filter
1	Clear
2	1/4 ND
3	1/16 ND
4	1/64 ND

If the setting of the FILTER selector is changed, a message reporting the setting appears for about 3 seconds in the setting change and adjustment progress message display area of the viewfinder screen (in display mode 3).

- Place a white test card under the same lighting conditions as for the subject to be shot and zoom up to it.

Alternatively, any white object such as a cloth or a wall can be used.

The absolute minimum white area is as follows:

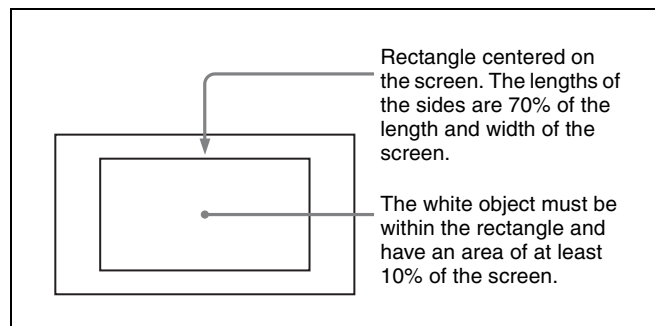

Note

Make sure there are not bright spots in the rectangle.

- Adjust the lens iris.

Manually adjusted lens: set the iris to an appropriate setting.

Lens with automatic iris: set the automatic/manual switch on the lens to automatic.

- Push the AUTO W/B BAL switch to WHT and then release the switch.

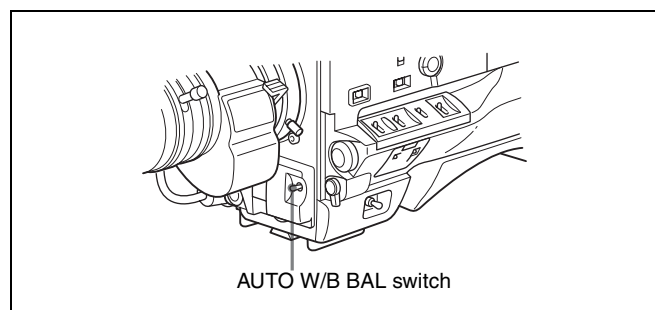

The switch returns to the center position, and the adjustment is executed.

During adjustment, the message “AWB : EXECUTING” is displayed on the viewfinder screen (in display mode 2 or 3).

The white balance adjustment ends in about one second with the message shown in the following

figure, and the adjustment setting is automatically stored in the memory (A or B) that was selected in step 1.

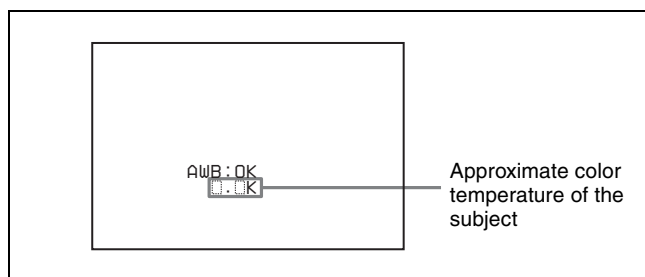

Note

If the camera has a zoom lens with an automatic iris, the iris may hunt ¹⁾ during the adjustment. To prevent this, adjust the iris gain knob (indicated as IG, IS, or S) on the lens.

1)Hunting

Repeated brightening and darkening of the image, resulting from repeated response to automatic iris control.

For details, refer to the lens operation manual.

If the automatic white balance adjustment cannot be made

If the white balance adjustment cannot be completed normally, an error message will appear for about 3 seconds on the viewfinder screen (in display mode 2 or 3). Possible messages are listed below.

White balance adjustment error messages

Error message	Meaning
AWB : NG LOW LEVEL	The white video level is too low. Either open the lens iris or increase the gain.
AWB : NG COLOR TEMP HIGH	The color temperature is too high. Select a suitable filter setting.
AWB : NG COLOR TEMP LOW	The color temperature is too low. Select a suitable filter setting.
AWB : NG TIME LIMIT	Adjustment could not be completed within the standard number of attempts.
AWB : NG POOR WHITE AREA	The white area could not be checked.
AWB : NG OVER LEVEL	The white video level is too high. Either stop down the lens iris or change the ND filter.

If any of the above error messages is displayed, retry the white balance adjustment. If the error message occurs again, contact your Sony service representative.

If you have no time to adjust the white balance

Set the WHITE BAL switch to PRST.

The white balance is automatically set as follows, depending on the FILTER selector setting.

B: 3200K

C: 4300K

D: 6300K

For details about setting the white balance manually, see “To automatically adjust the white balance” on page 61.

White balance memory

Values stored in memory are held until the white balance is next adjusted.

There are two sets of white balance memories, A and B, and adjustments for each of the filters can be automatically stored in the memory corresponding to the setting (A or B) of the WHITE BAL switch. The camcorder has four built-in filters, so a total of eight (4 × 2) adjustments can be stored. The number of memories allocated to each of A and B can be limited to one by setting the WHT FILTER INH. item to “ON” on the FUNCTION 3 page of the MAINTENANCE menu. In this case, the memory contents are not linked to the filter settings.

If the WHITE BAL switch is set to B, and on the FUNCTION 2 page of the OPERATION menu, the WHITE SWITCH item is set to “ATW,” the ATW (Auto Tracing White) function is activated to automatically adjust the white balance of the picture being shot for varying lighting conditions.

4-2 Setting the Electronic Shutter

This section describes the shutter modes that can be used with the electronic shutter of the camcorder, and describes the procedure for selecting the shutter speed and shutter mode.

4-2-1 Shutter Modes

The shutter modes that can be used with the electronic shutter and the shutter speeds that can be selected are shown below.

Standard mode

Use this mode for shooting fast-moving subjects with little blurring.

CCD scan mode		Shutter speed (sec.)
I	MSW-970	1/100, 1/125, 1/250, 1/500, 1/1000, 1/2000
	MSW-970P	1/60, 1/125, 1/250, 1/500, 1/1000, 1/2000
PsF	MSW-970	1/40, 1/60, 1/120, 1/125, 1/250, 1/500, 1/1000, 1/2000
	MSW-970P	1/33, 1/50, 1/100, 1/125, 1/250, 1/500, 1/1000, 1/2000
24P (MSW-970 only)		1/32, 1/48, 1/96, 1/125, 1/250, 1/500, 1/1000, 1/2000

ECS (Extended Clear Scan) mode

Use this mode for obtaining images with no horizontal bands of noise when shooting subjects such as monitor screens.

CCD scan mode		Shutter speed
I	MSW-970	60.00 to 6000 Hz
	MSW-970P	50.00 to 6000 Hz
PsF	MSW-970	30.00 to 7000 Hz
	MSW-970P	25.00 to 6000 Hz
24P (MSW-970 only)		24.00 to 5000 Hz

SLS (slow speed shutter) mode

The SLS mode can only be selected when the CCD scan mode is set to “I (interlace scan).”

Use this mode For shooting subjects in low level lighting conditions.

You can select the shutter speed from among 1 (1/30 sec for the MSW-970, 1/25 sec for the MSW-970P) to 8, 16

frames (1/2 sec for the MSW-970, 2/3 sec for the MSW-970P).

EVS (Enhanced Vertical definition System) mode

This mode is used to improved vertical resolution. However, the sensitivity and dynamic range are reduced. The shutter speed is set to the same value as that currently selected in Standard or ECS mode.

Notes

- Whatever the operating mode of the electronic shutter, the sensitivity of the CCD decreases with increasing shutter speed.
- When the automatic iris is used, the iris opens wider as the shutter speed increases, thus reducing the depth of field.
- Under artificial light, particularly fluorescent or mercury lamps, the light intensity may appear to be constant, but the red, green, and blue intensities are actually changing in synchronization with the frequency of the power supply causing flicker. Using an electronic shutter under such lighting could make the flicker even worse. Color flicker is particularly likely to happen when the power supply frequency is 60 Hz (with the MSW-970) or 50 Hz (with the MSW-970P). However, if the power frequency is 50 Hz (with the MSW-970) or 60 Hz (with the MSW-970P), setting the shutter speed to 1/100 or 1/60 can reduce this flicker.
- When a bright object is shot in EVS mode or ECS mode in such a manner that it fills the screen, the upper edge of the picture may have poor quality because of an inherent characteristic of CCDs. Before using EVS mode or ECS mode, check the shooting conditions.

You can turn on or off the EVS mode on the SW STATUS page of the PAINT menu.

4-2-2 Selecting the Shutter Mode and Shutter Speed

Use the SHUTTER selector to select a shutter mode or a standard-mode shutter speed. To set the shutter speed in ECS or SLS mode, with the SHUTTER selector set to ON and the ECS or SLS mode selected, use the MENU knob for adjustment.

You can use the SHT ENABLE page of the OPERATION menu to narrow the range of choice in advance, or to select in advance whether or not you use ECS/SLS.

Setting the shutter mode and the shutter speed in standard mode

Once the shutter speed is selected, it is retained even when the camcorder power is turned off.

- 1 Follow the procedure described in “5-2-2 Selecting the Display Items” (page 84) to set the VF DISPLAY MODE item to “2” or “3” on the VF DISP 1 page of the USER menu.
- 2 Push the SHUTTER selector from ON to SEL.

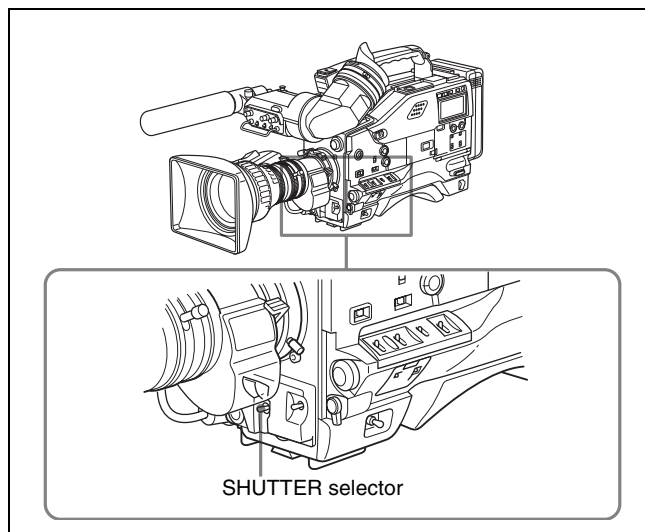

The current shutter setting indication appears for about 3 seconds in the setting change and adjustment progress message display area of the viewfinder screen.

Examples: “: SS : 1/250,” “: ECS : 60.00 Hz”

- 3 Before the shutter setting indication disappears, push the SHUTTER selector down to SELECT again and repeat this until the desired mode or speed appears.

Pushing the SHUTTER selector down to SELECT repeatedly allows you to cycle through the settings of mode and speed preselected on the SHT ENABLE page of the OPERATION menu.

Note that all modes and all standard-mode speeds listed in the table on the previous page are preselected using the SHT ENABLE page of the OPERATION menu.

By factory default, all available shutter modes and shutter speeds are displayed in the sequence shown in the following figure. (You can use the SHT ENABLE page of the OPERATION menu to make a setting so that only the desired (or most frequently used) modes and speeds are displayed.)

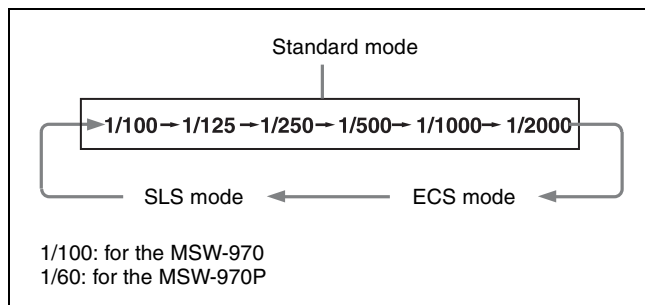

Setting the shutter speed in ECS mode

Proceed as follows:

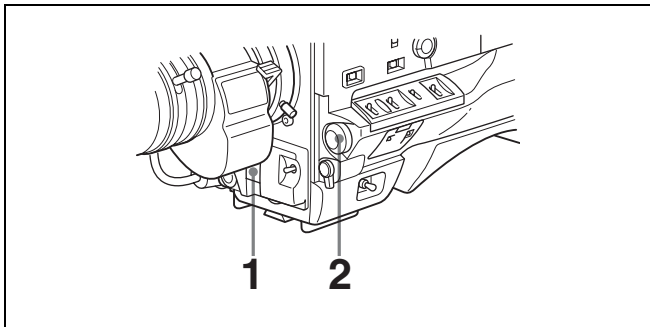

- 1 Set the shutter speed mode to ECS.

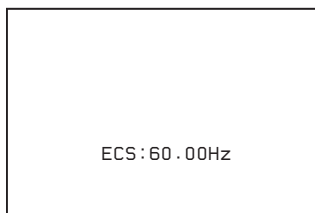

Example of view finder screen display for ECS setting operation

- 2 Turn the MENU knob counterclockwise as seen from the front of the camera to increase the value, or clockwise to decrease the value, until the desired frequency appears.

The frequency range can be changed between 60.1 and 7000 Hz (MSW-970) or between 50.2 and 9000 Hz (MSW-970P).

When the RM-B150/B750 Remote Control Unit is connected

You can set the shutter speed of ECS with the rotary encoder of the RM-B150/B750.

Setting the shutter speed in SLS mode

Proceed as follows:

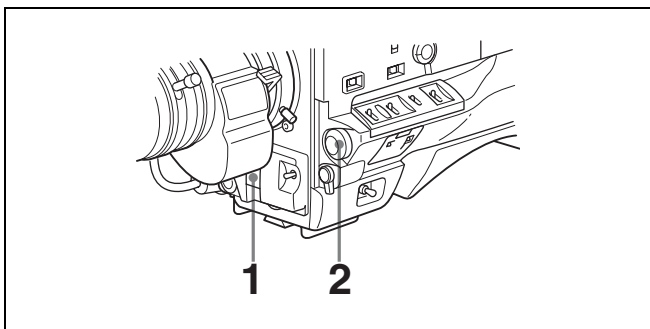

- 1 Set the shutter speed mode to SLS.

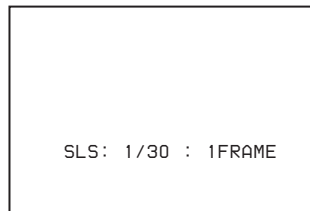

Example of view finder screen display for SLS setting operation

- 2 Turn the MENU knob until the desired number of frames appears.

The number of frames can be set to values in the range 1 to 8, and 16 (1 frame nearly equals to 1/30 second (MSW-970) or 1/25 second (MSW-970P)).

Changing the range of choice of shutter mode and speed settings

You can reduce the time required to select the shutter mode and speed by narrowing the choice of settings in advance. This can be done by using the SHT ENABLE page of the OPERATION menu.

Proceed as follows:

Note

The settings selected on the SHT ENABLE page of the OPERATION menu become invalid when the RM-B150/B750 Remote Control Unit is connected to the camcorder.

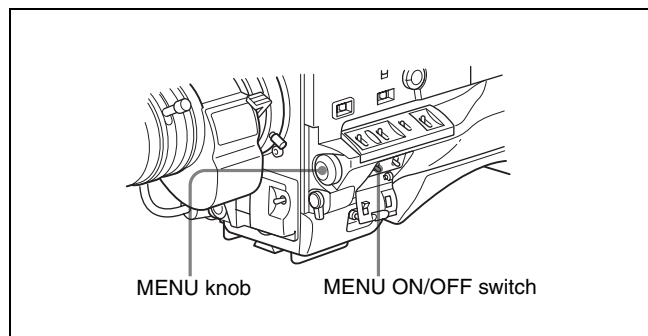

- 1 Set the MENU ON/OFF switch to ON while holding down the MENU knob.

The TOP menu appears.

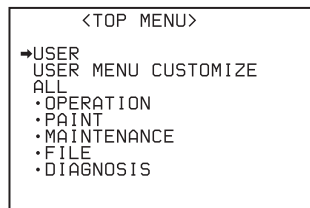

- 2 Turn the MENU knob to move the ► mark to OPERATION.

3 Press the MENU knob.

If this is the first time the OPERATION menu has been displayed, the CONTENTS page of the OPERATION menu appears.

If the menu has been used before, the last accessed page appears.

4 If the CONTENTS page is displayed, turn the MENU knob to move the ► mark to “SHT ENABLE,” then press the MENU knob to display the SHT ENABLE page.

If a different page is displayed, turn the MENU knob until the SHT ENABLE page appears, then press the MENU knob to select the page.

SHT ENABLE page

170SHT ENABLE			
►SHUTTER	SLS	:●	ON
SHUTTER	ECS	:	ON
SHUTTER	1/100	:	ON
SHUTTER	1/125	:	ON
SHUTTER	1/250	:	ON
SHUTTER	1/500	:	ON
SHUTTER	1/1000	:	ON
SHUTTER	1/2000	:	ON

(This menu display is for the MSW-970. For the MSW-970P, “SHUTTER 1/60” is displayed instead of “SHUTTER 1/100.”)

5 Turn the MENU knob to move the ► mark to the shutter mode or shutter speed you want, then press the MENU knob.

The ► mark on the left of the selected item changes to a ● mark and the ● mark on the left of the setting changes to a ? mark.

6 Turn the MENU knob until “ON” appears, then press the MENU knob.

The ● mark on the left of the selected item returns to a ► mark and the ? mark on the left of the setting returns to a ● mark.

To set another mode or speed, return to step 5.

Note that only the shutter speeds set to “ON” can be selected with the SHUTTER selector.

7 To end the menu operation, set the MENU ON/OFF switch to OFF.

The menu disappears from the viewfinder screen and the display indicating the current status of the camcorder appears along the top and bottom of the viewfinder screen.

Note

When you set “SHT DISP MODE” to “DEG” on the FUNCTION 4 page, the shutter speed indications in

seconds (e.g. 1/100) can be changed to degrees (360 is equivalent to shutter OFF).

4-3 Changing the Reference Value for Automatic Iris Adjustment

The reference value for automatic iris adjustment can be changed to aid the shooting of clear pictures of back-lit subjects, or to prevent blown-out highlights. The reference value for the lens iris can be set within the following range with respect to the standard value.

- 0.5: about 0.5 stop further open
- 1: about 1 stop further open
- -0.5: about 0.5 stop further closed
- -1: about 1 stop further closed

Changing the reference value

Proceed as follows:

- 1 Set the MENU ON/OFF switch to ON.

If this is the first time the USER menu has been displayed, the CONTENTS page of the USER menu appears. If the menu has been used before, the last accessed page appears.

- 2 If the CONTENTS page is displayed, turn the MENU knob to move the ➔ mark to AUTO IRIS, then press the MENU knob to display the AUTO IRIS page.

If a different page is displayed, turn the MENU knob until the AUTO IRIS page appears, then press the MENU knob to select the page.

AUTO IRIS page

U100AUTO IRIS		
➔ IRIS OVERRIDE	: ●	ON
IRIS SPEED	:	0
CLIP HIGH LIGHT	:	OFF
IRIS WINDOW	:	1
IRIS WINDOW IND	:	OFF
IRIS VAR WIDTH	:	245
IRIS VAR HEIGHT	:	72
IRIS VAR H POS	:	0
IRIS VAR V POS	:	0

- 3 Turn the MENU knob to move the ➔ mark to “IRIS OVERRIDE,” then press the MENU knob.

The ➔ mark on the left of the selected item changes to a ● mark and the ● mark on the left of the setting changes to a ? mark.

- 4 Turn the MENU knob until “ON” appears, then press the MENU knob.

The ● mark on the left of the selected item returns to a ➔ mark and the ? mark on the left of the setting returns to a ● mark.

The IRIS OVERRIDE item is set to “ON” (factory setting: OFF).

- 5 Set the MENU ON/OFF switch to OFF.

The AUTO IRIS page disappears from the viewfinder screen.

- 6 Turn the MENU knob to change the reference value.

The changed reference value is retained until the power of the camcorder is turned off. Even if the reference value is changed, it reverts to the standard value every time the power is turned on.

To open the iris by 0.5 stop:

Turn the MENU knob counterclockwise as seen from the front of the camera.

One bar (□) appears in the upper part to the left of the F number in the iris indication.

To open the iris by 1 stop:

Turn the MENU knob counterclockwise as seen from the front of the camera.

Two bars (□□) appear in the upper part to the left of the F number in the iris indication.

To stop down the iris by 0.5 stop:

Turn the MENU knob clockwise as seen from the front of the camera.

One bar (□) appears in the lower part to the left of the F number in the iris indication.

To stop down the iris by 1 stop:

Turn the MENU knob further clockwise as seen from the front of the camera.

Two bars (□□) appear in the lower part to the left of the F number in the iris indication.

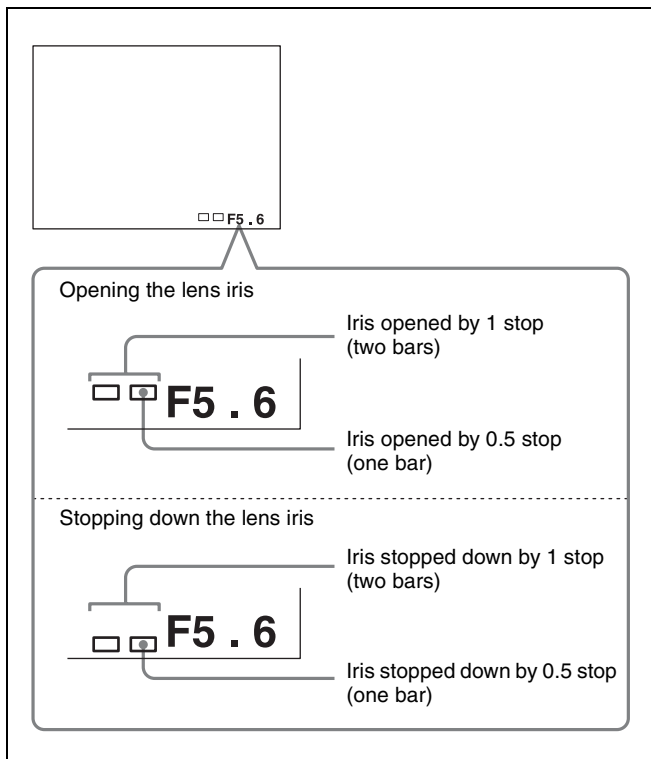

Adjusting the reference value for automatic iris adjustment

When the RM-B150/B750 Remote Control Unit is connected

The IRIS control knob of the RM-B150/B750 can be used for lens iris setting. In this case, the bar display (□) does not appear.

Selecting the automatic iris window

Proceed as follows:

- Follow the procedure of steps 1 and 2 described in the previous item “Changing the reference value” (page 67) to display the AUTO IRIS page.
- Turn the MENU knob to move the ➔ mark to “IRIS WINDOW IND,” then press the MENU knob.
The ➔ mark on the left of “IRIS WINDOW IND” changes to a ● mark, and the ● mark on the left of the setting changes to a ? mark.
- Turn the MENU knob until “ON” appears, then press the MENU knob.
The ● mark returns to a ➔ mark, and the ? mark returns to a ● mark.
The currently selected auto iris window appears on the screen.
If it is not necessary to display the auto iris window on the screen, set to “OFF.”

- Turn the MENU knob to move the ➔ mark to “IRIS WINDOW,” then press the MENU knob.

The ➔ mark changes to a ● mark, and the ● mark changes to a ? mark.

- Turn the MENU knob until the desired auto iris window appears, then press the MENU knob.

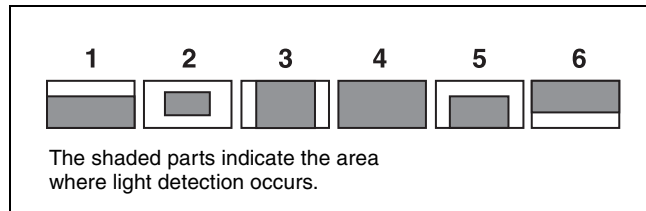

Auto iris window

The ● mark on returns to a ➔ mark and the ? mark returns to a ● mark.

If you select “VARIABLE,” the following items become effective and you can set the window of the desired size. Set each item to the desired size.

Item	Setting
IRIS VAR WIDTH	The width of the window
IRIS VAR HEIGHT	The height of the window
IRIS VAR H POS.	The position of the window in the horizontal direction
IRIS VAR V POS.	The position of the window in the vertical direction.

- Set the MENU ON/OFF switch to OFF or close the cover of the menu operating section.

The menu disappears from the viewfinder screen and the display indicating the current status of the camcorder appears along the top and bottom of the screen.

To counter problems with very bright highlights

If the subject is too bright, the iris may close too much, leaving the overall image dark, or the highlights may be blown out. In such cases, setting the highlight clip function on reduces the luminance range, avoiding problems from the automatic iris correction.

In the AUTO IRIS page of the USER menu, set the CLIP HIGH LIGHT item to “ON.”

4-4 Adjusting the Audio Level

Setting the AUDIO SELECT CH-1/CH-2 switches to AUTO automatically adjusts the input levels of the audio signal to be recorded in audio channels 1 and 2. You can also adjust the audio level manually.

For the audio level of the signal to be recorded in audio channels 3 and 4

Only automatic adjustment of the audio level is available. When the CH-1/2 / CH-3/4 switch is set to CH-3/4, the audio channel level meters display the level of the audio signals recorded in audio channels CH-3 and CH-4. You can select the audio input signals to be recorded for audio channel CH-3 and 4 by using the AUDIO IN CH-3/CH-4 switches.

4-4-1 Manually Adjusting the Audio Input Level of the AUDIO IN CH1/CH2 Connectors

Follow the procedure described below to adjust the audio levels of the audio input from the AUDIO IN CH1/CH2 connectors, which are to be recorded in audio channels CH-1 and CH-2.

Note

When **1** and **2** are not displayed under the audio channel level meters, the CH-1/2 / CH-3/4 switch is set to the CH-3/4 position. Set this switch to CH-1/2.

At the factory setting, the XLR connection automatic detection mode of the AUDIO IN CH1/CH2 connectors is set to OFF. If the setting has been changed to ON, start the operation from step **2**.

Start the operation from step **1** with the XLR connection automatic detection mode set to OFF.

You can set the XLR connection automatic detection mode on the AUDIO-1 page of the MAINTENANCE menu.

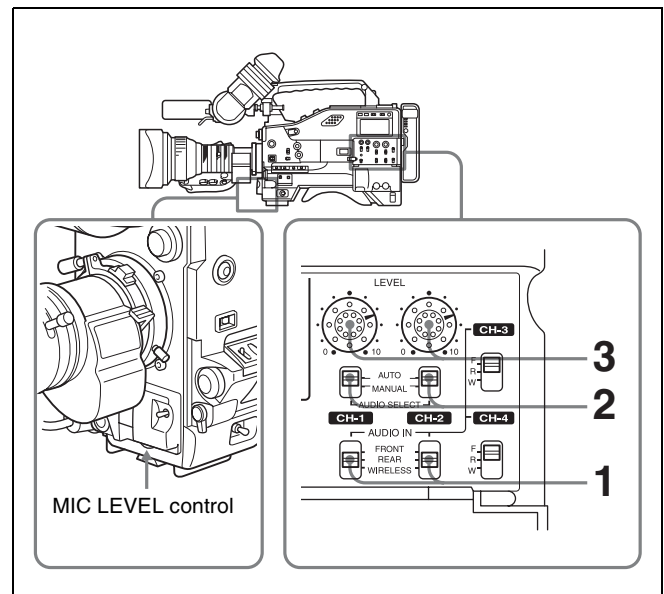

Manual adjustment of the audio levels of AUDIO IN CH1/CH2

- 1** To adjust the signal input to the AUDIO IN CH1 or AUDIO IN CH2 connector, set the AUDIO IN CH-1 or AUDIO IN CH-2 switch to REAR. To adjust both input signals, set both switches to REAR.
- 2** Set the AUDIO SELECT switch(es) corresponding to the channel(s) selected in step **1** to MANUAL.
- 3** With the LEVEL control for the channel selected in step **1**, adjust so that the audio level meter shows up to -20 dB for a normal input volume.

The second bar from the top may turn on occasionally, but do not allow the top bar (0 dB) to go on. If it goes on, the audio level is too high.

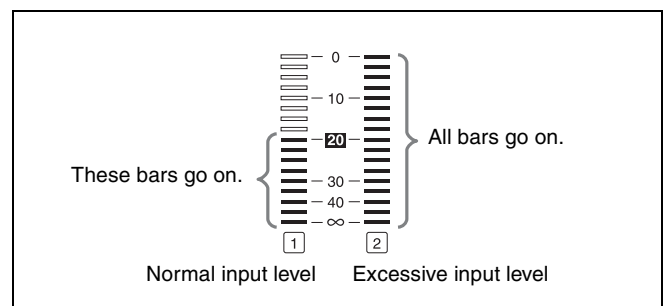

Using the LEVEL controls

You can select the audio level controls to be used to adjust the level of the audio signals input to the AUDIO IN CH1/CH2 connectors on the AUDIO-3 page of the MAINTENANCE menu.

	At the factory setting	Example 1	Example 2
Audio level to CH-1	LEVEL (CH-1) control	MIC LEVEL control	The MIC LEVEL control is linked with LEVEL (CH-1) control.
Audio level to CH-2	LEVEL (CH-2) control	MIC LEVEL control	The MIC LEVEL control is linked with LEVEL (CH-2) control.

Note

When you have operation of the LEVEL (CH-1/CH-2) controls and MIC LEVEL control linked together, if the MIC LEVEL control is set to 0, the audio signals on channels 1 and 2 cannot be recorded. Check the position of the MIC LEVEL control before adjusting the LEVEL (CH-1/CH-2) controls.

4-4-2 Manually Adjusting the Audio Level of the Front Microphone

You can adjust the audio level input from the front microphone connected to the MIC IN connector, which is to be recorded on audio channels 1 and 2.

Notes

- When **1** and **2** are not displayed under the audio channel level meters, the CH-1/2 / CH-3/4 switch is set to the CH-3/4 position. Set this switch to CH-1/2.
- If the XLR connection automatic detection mode is on, when the cables are connected to the AUDIO IN CH1/CH2 connectors, the camcorder detects the connection to the AUDIO IN CH1/CH2 connectors. Thus, the AUDIO IN switches are internally reset to REAR and the audio signals input to the AUDIO IN CH1/CH2 connectors are automatically selected.

Before adjusting the audio level of the front microphone, confirm that no cables are connected to the AUDIO IN CH1/CH2 connectors. Alternatively, set the REAR XLR AUTO item to “OFF” on the AUDIO-1 page of the MAINTENANCE menu.

To adjust the audio level of the front microphone, proceed as follows:

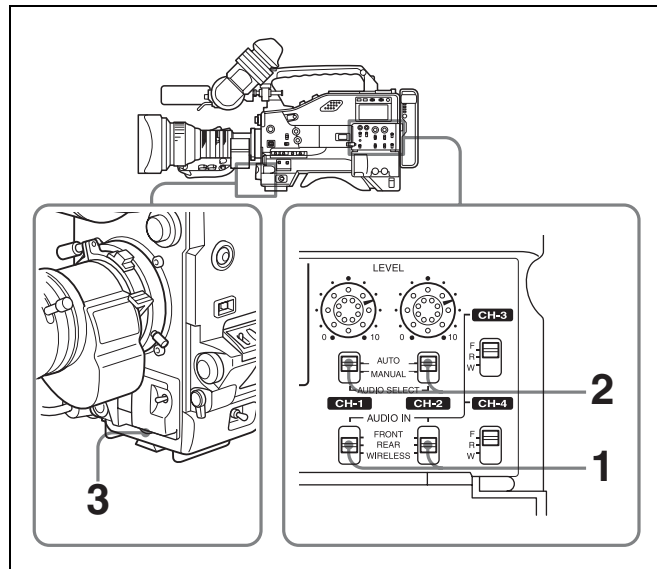

Manual adjustment of the audio levels of the front microphone

- Set either or both of the AUDIO IN switch(es) to FRONT as follows:
 - When using the front microphone input for both channels 1 and 2:** Set both AUDIO IN switches to FRONT.
 - When using the front microphone input for either channel 1 or 2:** Set the AUDIO IN switch for the desired channel to FRONT.
- Set the AUDIO SELECT switch(es) for the desired channel(s) selected in step 1 to MANUAL.
- Turn the MIC LEVEL control, and adjust so that the audio level meter shows up to -20 dB for a normal input volume.
 - The 9 bars from the bottom among 17 bars go on with the normal input volume.
 - The second top bar may turn on occasionally, but do not allow the top bar to go on. If it goes on, the audio level is too high.

Using the LEVEL controls

You can select the audio level controls to be used to adjust the level of the front microphone on the AUDIO-3 page of the MAINTENANCE menu.

	At the factory setting	Example 1	Example 2
Audio level to CH-1	LEVEL (CH-1) control	MIC LEVEL control	The MIC LEVEL control is linked with LEVEL (CH-1) control.
Audio level to CH-2	LEVEL (CH-2) control	MIC LEVEL control	The MIC LEVEL control is linked with LEVEL (CH-2) control.

Note

When you have operation of the MIC LEVEL control and LEVEL (CH-1/CH-2) controls linked together, if the LEVEL (CH-1/CH-2) controls are set to 0, the audio signals on channels 1 and 2 cannot be recorded. Check the position of the LEVEL (CH-1/CH-2) controls before adjusting the MIC LEVEL control.

4-4-3 Input level of audio channels CH-3 and CH-4

The levels of the audio signals recorded in audio channels CH-3 and CH-4 are automatically adjusted. You cannot adjust them manually.

You can select the audio signal to be recorded in audio channels CH-3 and CH-4 using the AUDIO IN CH-3 and CH-4 switches.

Note

The XLR connector automatic detection function does not affect audio signals recorded on audio channels CH-3 and CH-4.

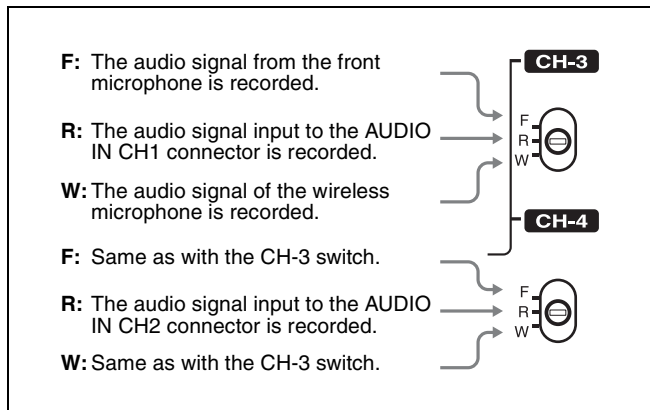

Audio signals to be recorded on audio channels 3 and 4

4-5 Setting the Time Data

4-5-1 Setting the Time Code

The time code setting range is from 00 : 00 : 00 : 00 to 23 : 59 : 59 : 29 (hours : minutes : seconds : frames) for the MSW-970, and from 00 : 00 : 00 : 00 to 23 : 59 : 59 : 24 for the MSW-970P.

To set the time code, proceed as follows:

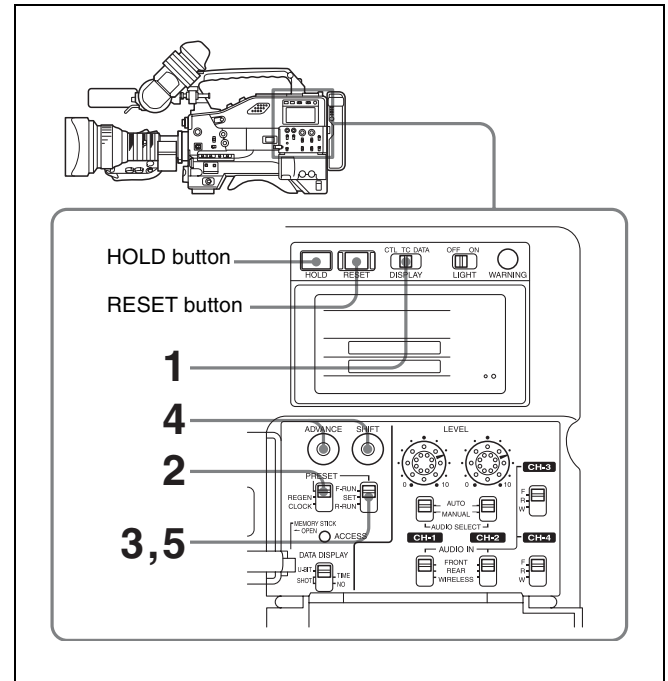

Setting the time code

- 1 Set the DISPLAY switch to TC.
- 2 Set the PRESET/REGEN/CLOCK switch to PRESET.
- 3 Set the F-RUN/SET/R-RUN switch to SET.

The first (leftmost) digit of time code flashes.

- 4 Using the SHIFT and ADVANCE buttons, set the time code.

SHIFT: Selects a digit to set. Each time you press the button, the flashing digit moves one column to the right.

Pressing this button while holding down the HOLD button moves the flashing digit one to the left.

ADVANCE: Increments the value of the flashing digit.

Pressing this button while holding down the HOLD button decrements the flashing digit.

To reset the time code value to 00:00:00:00

Press the RESET button.

- 5 Set the F-RUN/SET/R-RUN switch to F-RUN or R-RUN.

F-RUN: Free run. The time code generator keeps running.

R-RUN: Recording run. The time code generator runs only while recording.

To set the drop frame mode/non-drop frame mode (only for the MSW-970)

You can select the drop frame (DF) mode or non-drop frame (NDF) mode on the FUNCTION 1 page of the USER menu or OPERATION menu or on the TIMECODE page of the MAINTENANCE menu.

To make the time code consecutive

When the F-RUN/SET/R-RUN switch is set to R-RUN, recording a number of scenes on the tape normally produces consecutive time code. However, once you remove the tape and record on another tape, the time code will no longer be contiguous when you use again the original tape for recording. In this case, to make the time code consecutive, proceed as follows:

- 1 Set the PRESET/REGEN/CLOCK switch to REGEN.
- 2 Use the PLAY buttons to play back.
- 3 Watching the playback, find the point of the previous recording on the tape from which you wish to continue recording, and press the STOP button.
- 4 Press the RET button on the lens.

This reads the previous recording and synchronizes the internal time code generator, thus allowing the new time code recorded to follow on consecutively.

4-5-2 Saving the Actual Time in the Time Code

Setting the PRESET/REGEN/CLOCK switch to CLOCK saves the actual time in the time code.

When it is necessary to set the actual time, use the TIME/DATE page of the DIAGNOSIS menu.

For details, see “5-3-6 Setting the Date/Time of the Internal Clock” on page 97.

4-5-3 Setting the User Bits

By setting the user bits (up to 8 hexadecimal digits), you can record user information such as the date, time, or scene number on the time code track.

To set the user bits, proceed as follows:

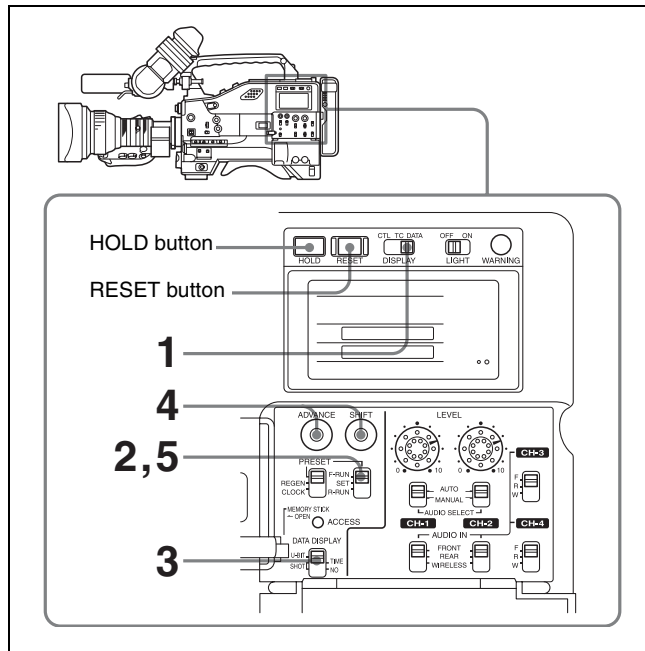

Setting the user bits

- 1 Set the DISPLAY switch to DATA.
- 2 Set the F-RUN/SET/R-RUN switch to SET.
- 3 Set the DATA DISPLAY switch to U-BIT.
- 4 Set the user bits by using the SHIFT and ADVANCE buttons.

SHIFT: Selects a digit to set. Each time you press the button, the flashing digit moves one column to the right. Pressing this button while holding down the HOLD button moves the flashing digit one to the left.

ADVANCE: Increments the value of the flashing digit. Pressing this button while holding down the HOLD button decrements the flashing digit.

Hexadecimal digits A to F are displayed as follows:

Hexadecimal	A	B	C	D	E	F
Display	A	b	C	d	E	F

To reset the user bit data to 00:00:00:00

Press the RESET button.

- Set the F-RUN/SET/R-RUN switch to F-RUN or R-RUN, corresponding to the desired operating mode for the time code generator.

The set user bit data will be recorded for both LTC and VITC.

To store the user bit setting in memory

The user bit setting (apart from the real time) is automatically retained in memory even when the power is turned off.

4-5-4 Synchronizing the Time Code

You can synchronize the internal time code generator of this camcorder with an external generator for the regeneration of an external time code. You can also synchronize the time code generators of other camcorders/VTRs with the internal generator of this camcorder.

Connections for time code synchronization

Connect both the reference video signal and the external time code as illustrated below.

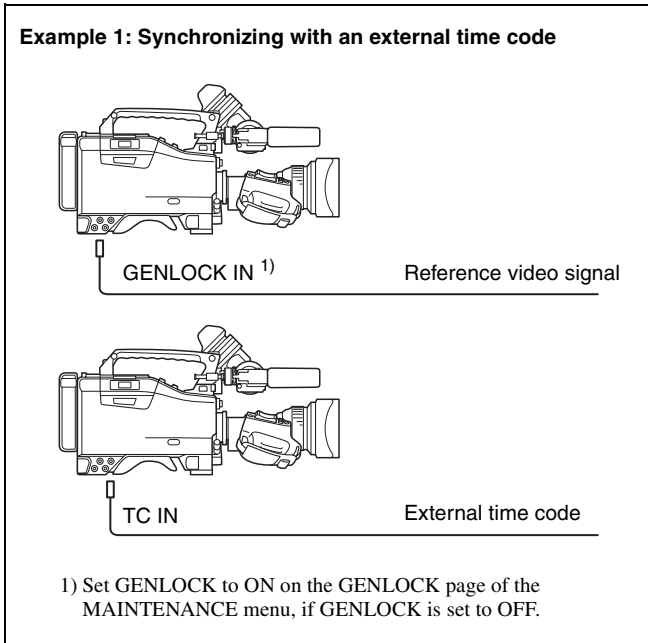

Example 2: Interconnecting a number of camcorders for time code synchronization

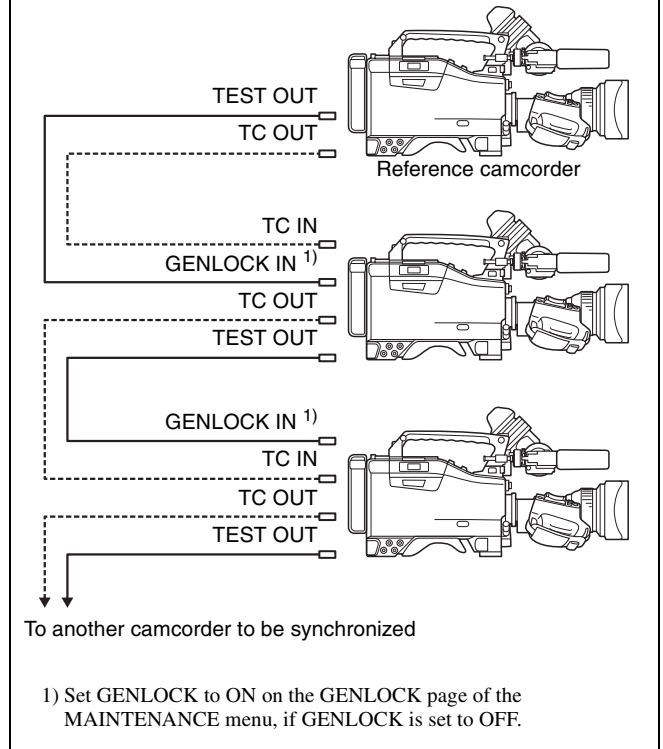

Procedure for time code synchronization

To synchronize the time code, proceed as follows:

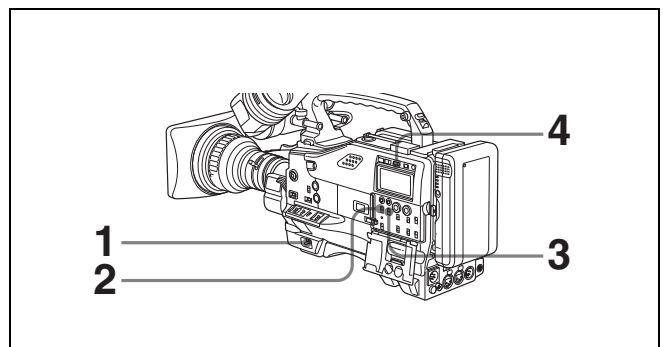

- Turn on the POWER switch.
- Set the PRESET/REGEN/CLOCK switch to PRESET.
- Set the F-RUN/SET/R-RUN switch to F-RUN.
- Set the DISPLAY switch to TC.
- Supply a time code signal and a reference video signal complying with the SMPTE (for the MSW-970) or EBU (for the MSW-970P) standard and in proper phase relationship, to the TC IN connector and to the GENLOCK IN connector, respectively.

This operation synchronizes the internal time code generator with the external time code. After about 10 seconds, you can disconnect the external time code without losing the synchronization. However, there will be noise on the recorded image if you connect or disconnect the time code signal during recording.

Notes

- When you finish the above procedure, the internal time code is immediately synchronized with the external time code and the counter display will show the value of the external time code. However, wait for a few seconds until the sync generator stabilizes before recording.
- If the frequency of the reference video signal is not the same as the frame frequency of the camcorder, the camera cannot be correctly genlocked. In such a case, the internal time code is not correctly synchronized with the external time code.
- When the GENLOCK ON/OFF item is set to “OFF” on the GENLOCK page of the MAINTENANCE menu, the time code cannot be synchronized with the reference video signal. In this case, set the GENLOCK item to “ON” on the GENLOCK page of the MAINTENANCE menu.

User bit settings during time code synchronization

When the time code is synchronized, only the time data is synchronized with the external time code value. Therefore, the user bits can have their own settings for each camcorder.

To synchronize the user bits with external user bit data, set the EXT-LK UBIT item on the TIME CODE page of the MAINTENANCE menu to “EXT.”

To release the time code synchronization

First disconnect the external time code, then set the F-RUN/SET/R-RUN switch to R-RUN.

To change the power supply from the battery pack to an external power supply during time code synchronization

To maintain a continuous power supply, connect the external power supply to the DC IN connector before removing the battery pack. You may lose time code synchronization if you remove the battery pack first.

Camera synchronization during time code synchronization

During time code synchronization, the camera is genlocked to the reference video signal input from the GENLOCK IN connector.

5-1 Menu Organization and Operation

5-1-1 Menu Organization

The following shows the organization of menus that you can use to make various settings and adjustments.

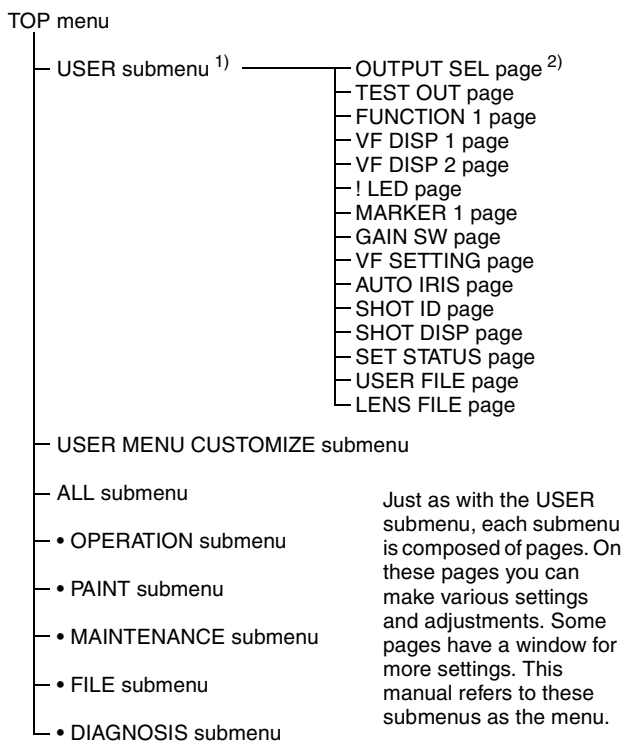

1) In this manual, the USER menu consisting of items and pages registered at the factory is used. You use the USER MENU CUSTOMIZE menu to add or delete pages according to how the camcorder is being used.

2) This menu appears only when the CBK-SD01 is installed.

For details, see “5-1-3 Editing the USER Menu” on page 78.

TOP menu

The menus of the camcorder are composed of submenus classified into categories according to the frequency of use,

purpose of use and so on. The TOP menu allows you to select the desired submenus.

To display the TOP menu screen

While holding down the MENU knob, set the MENU ON/OFF switch from the OFF position to the ON position.

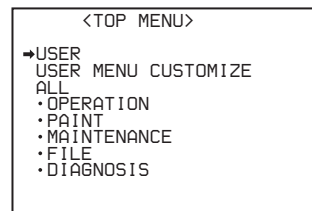

Note

Depending on the internal switch settings, display of the TOP menu may be disabled.

For details, ask your Sony service representative.

Submenus selected in the TOP menu

These are the following menus.

• USER menu

This menu includes monitor output settings, viewfinder settings, and commonly used functions. This menu is normally displayed when the MENU ON/OFF switch is changed to ON.

• USER MENU CUSTOMIZE menu

This menu allows you to add pages to or delete pages from the USER menu to suit your needs.

• ALL menu

This menu contains all items of the OPERATION menu, PAINT menu, MAINTENANCE menu, FILE menu and DIAGNOSIS menu.

• OPERATION menu

This menu contains items for changing settings according to conditions related to the subject when the camcorder is being operated.

• PAINT menu

This menu contains items for making detailed image adjustments while using a waveform monitor to monitor the waveforms output by the camera. Support of a video engineer is usually required to use this menu. Although you can also use an external remote control panel or master setup unit to set the items on this menu, this menu is effective when using the camcorder by itself outdoors.

• MAINTENANCE menu

This menu contains items for performing camera maintenance operations, such as changing the system or using infrequently used “paint” items.

• FILE menu

This menu is for performing file operations, such as writing the reference file.

• DIAGNOSIS menu

This menu enables you to confirm the VTR status or identify a failed circuit board.

Returning to the TOP menu from other menus

There are two methods.

- Align the \blacktriangleright mark with “TOP” at the top right of the menu page, and press the MENU knob.
- Push the CANCEL/PRST / ESCAPE switch down to the ESCAPE position repeatedly until the TOP menu appears.

5-1-2 Basic Menu Operations

When you open the cover of the menu operating section, the MENU ON/OFF switch appears. If the MENU ON/OFF switch is set to ON, the menu is displayed on the viewfinder screen. Closing the cover automatically sets the MENU ON/OFF switch to OFF.

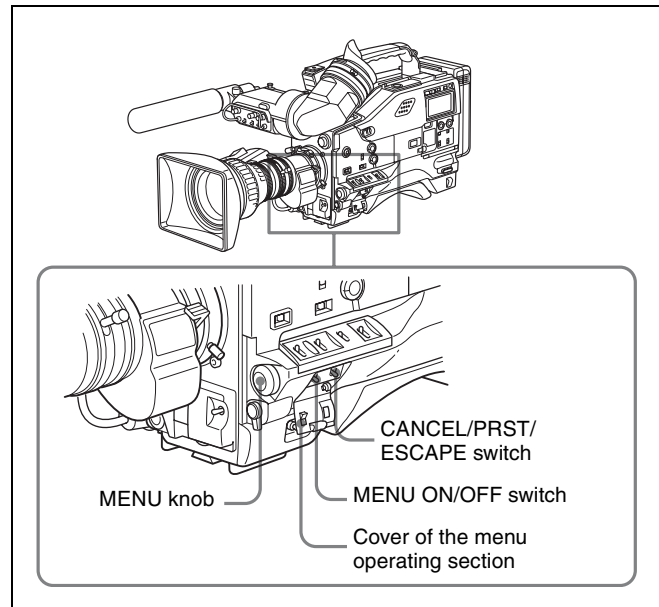

Controls used for the basic use of the menu operations

This section explains operations on the USER menu. But the operations are the same as those on menus other than the USER menu. Also, if the optional extension boards are not installed in your camcorder, some items on the USER menu pages are not displayed.

Proceed as follows:

- 1 Switch the MENU ON/OFF switch from OFF to ON.

A USER menu page normally appears.

Example:

?U030FUNCTION1	
ASSIGN SW <1>	: ATW
ASSIGN SW <2>	: OFF
TURBO SW	: TURBO
DF/NDF	: DF
END SEARCH	: OFF
CACHE/INTVAL REC	: OFF

(For the MSW-970P, the DF/NDF item is not included.)

If the USER menu has been used before, the last accessed page appears. In this case, go to step **2**. If this is the first time the USER menu has been displayed, the CONTENTS page of the USER menu appears. In this case, follow the procedure below.

- ① Turn the MENU knob to move the \blacktriangleright mark to the desired page number.

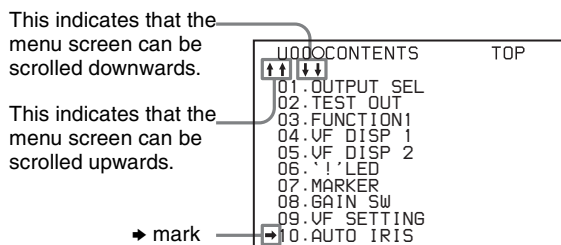

② Press the MENU knob.

The selected page is displayed.
Go to step 4.

2 Turn the MENU knob until the desired page appears.

3 Press the MENU knob.

A → mark appears on the left of the item currently selected on the page.

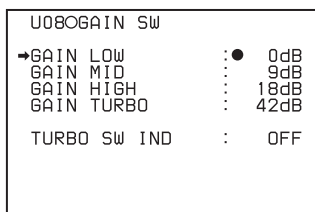

4 Turn the move MENU knob to move the → mark to the desired item.

- Turning the MENU knob counterclockwise as seen from the front of the camera moves the → mark up continuously.
- Turning the MENU knob clockwise as seen from the front of the camera moves the → mark down continuously.

5 Press the MENU knob.

The → mark on the left of the selected item changes to a ● mark, and the ● mark on the left of the setting changes to a ? mark.

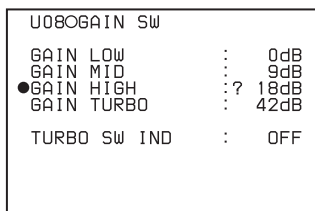

6 Turn the MENU knob to change the setting.

To increase a setting value

Turn the MENU knob counterclockwise as seen from the front of the camera.

To decrease a setting value

Turn the MENU knob clockwise as seen from the front of the camera.

As turning the MENU knob, the setting increases or decreases one step by one step.

If you turn the knob quickly, the numeric value changes rapidly. If you turn it slowly, you can make minute adjustments.

To toggle a setting on or off

To select the ON setting, turn the MENU knob counterclockwise as seen from the front of the camera.

To select the OFF setting, turn the MENU knob clockwise as seen from the front of the camera.

To cancel the setting/to reset the setting to the initial setting

You can cancel the setting and reset it to its initial value (one set at the factory, or preset value) by pushing the CANCEL/PRST / ESCAPE switch to CANCEL/ PRST before pushing the MENU knob in step 7.

When the CANCEL/PRST / ESCAPE switch is set to CANCEL/PRST, the message CANCEL? appears. To cancel the previous setting, push the CANCEL/PRST/ ESCAPE switch to CANCEL/PRST again.

To reset the setting to the initial value, push the CANCEL/PRST/ESCAPE switch to CANCEL/PRST a third time. The message PRESET? appears. To reset to the initial setting, push the CANCEL/PRST/ ESCAPE switch to CANCEL/PRST once more.

The action of the CANCEL/PRST function differs for some setting items. Some items are only affected by PRST. Check the setting procedure for each item for more information.

To interrupt changing the settings

By setting the MENU ON/OFF switch to OFF, the menu disappears from the screen. By setting the MENU ON/OFF switch to ON again, the values that were displayed when you interrupted the setting operations will reappear so you can continue making settings.

7 Press the MENU knob.

The ● mark returns to a → mark, and the ? mark returns to a ● mark. The setting is confirmed.

8 To continue setting other items in the same page, repeat steps from 4 to 7.

To move to another page

Proceed as follows:

1 Turn the MENU knob to move the → mark to the page number, then press the MENU knob.

If the ➔ mark is placed at a position other than the page number, push the CANCEL/PRST / ESCAPE switch to ESCAPE.

A ? mark appears in front of the page number. The camcorder is now in page selecting mode.

- 2 Turn the MENU knob until the desired page appears.
- 3 Press the MENU knob when the desired page appears.

To end menu operations

You can end menu operations using the following two methods:

- Turn the MENU ON/OFF switch to OFF.
- Close the cover of the menu operating section. When you close the cover, the MENU ON/OFF switch is set to OFF automatically.

The menu disappears from the viewfinder screen, and the display indicating the current status of the camcorder appears along the top and bottom of the screen (when the viewfinder DISPLAY switch is set to ON or the VF DISP item on the VF DISP 1 page of the USER menu is set to “ON”).

For details of the viewfinder display, see “5-2-2 Selecting the Display Items” on page 84.

5-1-3 Editing the USER Menu

The USER MENU CUSTOMIZE menu allows you to configure a USER menu that consists only of pages and items that you need by adding, deleting or replacing the pages.

Adding a new page

The USER MENU CUSTOMIZE menu allows you to add a new page to the USER menu.

While the EDIT page contains factory-preset items, the USER 1 EDIT to USER 19 EDIT pages and the ASSIGN SEL EDIT page are all blank in their initial state. You can register up to 10 items, including blank lines, on each of these pages.

To add a new page, proceed as follows:

- 1 While holding down the MENU knob, move the MENU ON/OFF switch from the OFF position to the ON position.

The TOP menu appears.

- 2 Turn the MENU knob to move the ➔ mark to “USER MENU CUSTOMIZE,” then press the MENU knob.

If this is the first time the USER MENU CUSTOMIZE menu has been displayed, the CONTENTS page of the menu appears.

E000	CONTENTS	TOP
01.	EDIT PAGE	
02.	USER 1	EDIT
03.	USER 2	EDIT
04.	USER 3	EDIT
05.	USER 4	EDIT
06.	USER 5	EDIT
07.	USER 6	EDIT
08.	USER 7	EDIT
09.	USER 8	EDIT
10.	USER 9	EDIT

If the USER MENU CUSTOMIZE menu has been used before, the last accessed page appears.

- 3 If the CONTENTS page is displayed, turn the MENU knob to move the ➔ mark to one of USER 1 EDIT to USER 19 EDIT and ASSIGN SEL EDIT, then press the MENU knob to display the page.

If a different page is displayed, turn the MENU knob until the desired page appears, then press the MENU knob to select the page.

Example: When you select the USER 2 EDIT page

E020	USER 2 EDIT	TOP
➔		

- 4 Move the ➔ mark to the item to be added (this operation is unnecessary, if no item exists on the page as shown in the figure for step 3), then press the MENU knob.

The EDIT FUNCTION display appears.

	EDIT FUNCTION	ESC
➔	INSERT	
	MOVE	
	DELETE	
	BLANK	

- 5 Move the ➔ mark to “INSERT,” and press the MENU knob.

The page for the last added item appears.

P250	BLACK/FLARE	ESC
MASTER	BLACK	0
R	BLACK	0
B	BLACK	0
MASTER	FLARE	0
R	FLARE	0
G	FLARE	0
B	FLARE	0
FLARE		ON
TEST OUT	SELECT	ENC

- 6 Add the items.
 - ① Turn the MENU knob until the page that has the desired items appears, then press the MENU knob.
 - ② Turn the MENU knob to move the ► mark to the desired item, then press the MENU knob.

The USER 2 EDIT page appears again, displaying the newly added item.

- 7 Add the remaining items by repeating steps 4 to 6.

You can add up to 10 items on one page.

To delete items from a page by using the CANCEL/PRST / ESCAPE switch

You can delete items from any of the USER 1 EDIT to USER 19 EDIT pages. Proceed as follows:

- 1 Turn the MENU knob to move the ► mark to the item to be deleted.
- 2 Push the CANCEL/PRST / ESCAPE switch to CANCEL/PRST.

The message “PRESET DATA OK?” appears.
- 3 Push the CANCEL/PRST / ESCAPE switch to CANCEL/PRST again.

The item is deleted.

To delete items from a page by using the menu

Proceed as follows:

- 1 Move the ► mark to the item to be deleted, and press the MENU knob.

The EDIT FUNCTION page appears.
- 2 Select “DELETE,” and press the MENU knob.

The previously displayed page appears again, and the message “DELETE OK? YES ► NO” appears at the upper right.
- 3 To delete, turn the MENU knob to move the ► mark to “YES,” and press the MENU knob.

To change the order of the items on a page

Proceed as follows:

- 1 Turn the MENU knob to move the ► mark to the item to be replaced, then press the MENU knob.

The EDIT FUNCTION page appears.

- 2 Select MOVE, then press the MENU knob.

The previously displayed page appears again.

- 3 Turn the MENU knob to move the ► mark to the position where you want to move the item, then press the MENU knob.

E020USER 1 EDIT	TOP
►WHITECH	: AWB
TEST OUT MENU	: OFF
OFFSET WHITE <A>	: OFF
WARM COOL <A>	: 3200
COLOR FINE <A>	: 0
●MASTER BLACK	: 0

The item selected in step 1 moves to the position that you selected in step 3.

In the above example, “MASTER BLACK” is moved to the top and the other items are moved down one line.

To insert a blank line

You can insert a blank line above the selected item. Proceed as follows:

- 1 Turn the MENU knob to move the ► mark to the item above which you want to insert a blank line.

The EDIT FUNCTION page appears.
- 2 Select “BLANK,” and press the MENU knob.

The previously displayed page appears again, and a blank line is inserted above the specified item.

Note

You cannot insert a blank line on a page where 10 items have already been registered.

Adding/deleting/replacing pages

You can add a new page to the USER menu, delete a page from the USER menu or replace pages, using the EDIT PAGE of the USER MENU CUSTOMIZE menu.

To add a page

Proceed as follows:

- 1 While holding down the MENU knob, move the MENU ON/OFF switch from the OFF position to the ON position.

The TOP menu appears.

- 2 Turn the MENU knob to move the ► mark to “USER MENU CUSTOMIZE,” then press the MENU knob.

If this is the first time the USER MENU CUSTOMIZE menu has been displayed, the CONTENTS page of the

menu appears. If the menu has been used before, the last accessed page appears.

- 3 If the CONTENTS page is displayed, turn the MENU knob to move the ➔ mark to “EDIT PAGE,” then press the MENU knob to display the EDIT PAGE screen. If a different page is displayed, turn the MENU knob until the EDIT PAGE screen appears, then press the MENU knob to select the page.

```

EDIT PAGE
E010EDIT PAGE TOP
  ↓↓
01.OUTPUT
➔02.TEST OUT
03.FUNCTION 1
04.VF DISP 1
05.VF DISP 2
06.'! LED
07.MARKER 1
08.GAIN SW
09.VF SETTING
10.AUTO IRIS
  
```

- 4 Turn the MENU knob to move the ➔ mark to where you want to add the page, then press the MENU knob.

The EDIT FUNCTION display appears.

```

EDIT FUNCTION ESC
➔INSERT
MOVE
DELETE
BLANK
  
```

- 5 Select INSERT, and press the MENU knob.

The selection screen appears.

```

CONTENTS ESC
➔01.USER PAGE 1
02.USER PAGE 2
03.USER PAGE 3
04.USER PAGE 4
05.USER PAGE 5
06.USER PAGE 6
07.USER PAGE 7
08.USER PAGE 8
09.USER PAGE 9
  
```

- 6 Turn the MENU knob to move the ➔ mark to the desired page, then press the MENU knob.

This adds the number and name of the selected page above the item selected in step 4.

To cancel adding a page

Before pressing the MENU knob in step 6, turn the MENU knob to move the ➔ mark to “ESC” at the top right of the screen, then press the MENU knob. The EDIT PAGE screen appears again.

To delete a page by using the CANCEL/PRST / ESCAPE switch

Proceed as follows:

- 1 Open the EDIT PAGE and turn the MENU knob to move the ➔ mark to the page to be deleted.
- 2 Push the CANCEL/PRST / ESCAPE switch to CANCEL/PRST.

The message “DELETE PAGE OK?” appears.

```

E010EDIT PAGE
DELETE PAGE OK ?
01.OUTPUT
02.TEST OUT
03.FUNCTION 1
➔04.VF DISP 1
05.VF DISP 2
06.'! LED
07.MARKER 1
08.GAIN SW
09.VF SETTING
10.AUTO IRIS
  
```

- 3 Push the CANCEL/PRST / ESCAPE switch to CANCEL/PRST again.

In the above example, the VF DISP 1 page is deleted.

To delete a page by using the menu

Proceed as follows:

- 1 On the EDIT PAGE screen of the USER MENU CUSTOMIZE menu, move the ➔ mark to the page to be deleted, and press the MENU knob.

The EDIT FUNCTION page appears.

- 2 Select DELETE, and press the MENU knob.

The previously displayed page appears again, and the message “DELETE PAGE OK?” appears at the upper right.

- 3 To delete, turn the menu knob to move the ➔ mark to “YES,” and press the MENU knob.

To change the order of pages

Proceed as follows:

- 1 Display the EDIT PAGE screen of the USER MENU CUSTOMIZE menu. Turn the MENU knob to move the ➔ mark to the page that you want to move.

The EDIT FUNCTION page appears.

- 2 Select MOVE, then press the MENU knob.

The EDIT PAGE screen appears again.

- 3 Turn MENU knob to move the ➔ mark to the position to where you want to move the page selected in step 1.

```
E01OEDIT PAGE
  PUSH TO PAGE INSERT
01.OUTPUT
02.TEST OUT
03.FUNCTION 1
→04.VF_DISP 1
05.' 'LED
06.MARKER 1
07.GAIN SW
08.VF_SETTING
●09.AUTO IRIS
```

4 Press the MENU knob.

The page selected in step **1** is moved to the position selected in step **3**.

In the above example, “AUTO IRIS” moves to the “04” position and the “VF DISP 1” and following items move down one line.

5-2 Status Display on the Viewfinder Screen

The viewfinder screen displays not only the video picture but also characters and messages indicating the camcorder settings and operating status, a center marker, a safety zone marker, etc.

When the MENU ON/OFF switch is set to OFF and the DISPLAY switch is set to ON, the items for which an “ON” setting was made in the VF DISP1 page of the USER menu or with related switches are displayed at the top and bottom of the screen. The messages that give details of the settings and adjustment progress and results can also be made to appear for about 3 seconds while settings are being changed, during adjustment, and after adjustment.

For information about the display item selection, see “5-2-2 Selecting the Display Items” on page 84.

For information about setting change and adjustment progress messages, see “5-2-3 Display Modes and Setting Change Confirmation/Adjustment Progress Messages” on page 85.

For information about marker display, see “5-2-4 Setting the Marker Display” on page 86.

5-2-1 Layout of the Status Display on the Viewfinder Screen

All items that can be displayed on the viewfinder screen are shown below.

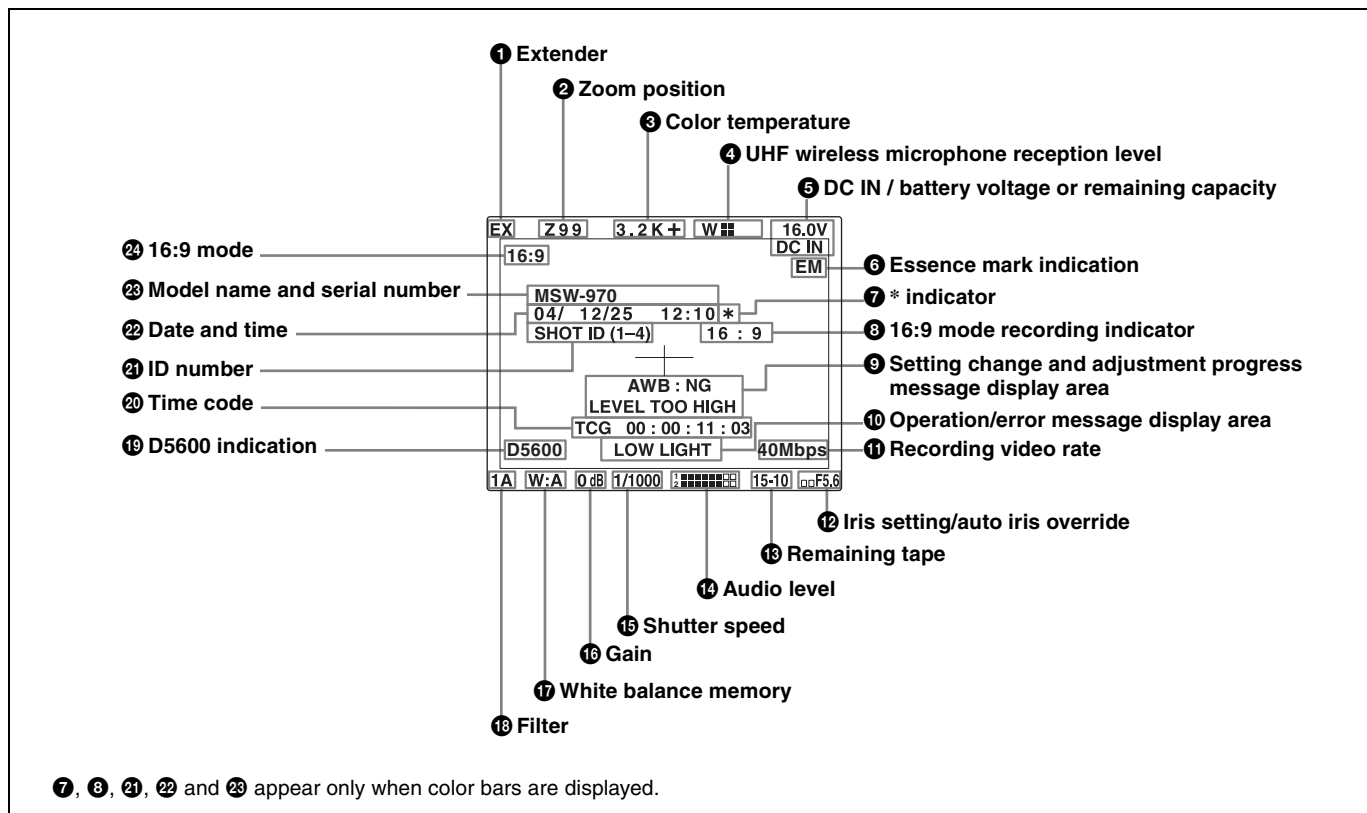

Status display on the viewfinder

① Extender

“EX” is displayed when a lens extender is used.

② Zoom position

This indicator appears only when you use a lens that has a zoom position display function. It indicates the approximate position of the variator¹⁾ of the zoom lens, between wide angle and telephoto.

1) Variator

A group of lenses that are moved to adjust the focal length.

3 Color temperature

This indicates the currently selected color temperature.

4 UHF wireless microphone reception level

This indicates reception level of the wireless microphone when the UHF wireless microphone is attached, using four ■ which appear at the right of “W.” When four ■ are lit, the receiving condition is good.

5 DC IN / battery voltage or remaining capacity

This shows the battery voltage or remaining capacity of an internal battery pack.

When the power is supplied from an AC adaptor connected to the DC IN connector, “DC IN” appears.

When the DISP BATT REMAIN item is set to “INT” on the VF DISP 2 page of the USER menu, the battery voltage is not indicated. However, when the Anton Bauer intelligent battery system or the BP-GL65/GL95/L60S battery pack is used, the remaining battery capacity is automatically detected and indicated as a percentage even when the DISP BATT REMAIN item is set to “OFF.” The indicated value changes in steps of 10%.

- Until the remaining battery capacity is reduced to 40%, the indications MAX, 90%, 80%...40% are displayed for 3 seconds in the viewfinder each time the remaining battery capacity reduces by 10%.
- When the remaining battery capacity is less than 40%, the indication is displayed all the time.
- When the remaining battery capacity is less than 10%¹⁾, the indication flashes. When the remaining battery capacity is reduced further, the LOW indication flashes.

1) This value can be set to either 10% or 20% on the FUNCTION 2 page of the OPERATION menu.

6 Essence mark indication

This appears when an essence mark has been recorded.

7 * indicator

This flashes when the color bars are displayed and is recorded together with the color bars.

8 16:9 mode recording indicator

This indicates recording in the 16:9 mode. This indicator is recorded together with the color bars.

9 Setting change and adjustment progress message display area

For details, see “5-2-3 Display Modes and Setting Change Confirmation/Adjustment Progress Messages” on page 85.

10 Operation/error message display area

For details, see “Operation/error messages” on page 135.

11 Recording video rate

This appears when REC VIDEO RATE is set to 40M or 30M on the VTR MODE page of the MAINTENANCE menu.

12 Iris setting/auto iris override

This indicates the f-stop (iris setting) of the lens.

Also, the auto iris override is displayed using bars which appear in the upper and lower parts to the left of the F number respectively.

For details, see “Changing the Reference Value for Automatic Iris Adjustment” on page 67.

13 Remaining tape

This indicator indicates the remaining tape recording time (in minutes) of the VTR.

Examples of remaining disc recording time indication

Indication	Remaining disc recording time
F – 30	Full to 30 minutes
30 – 25	30 to 25 minutes
25 – 20	25 to 20 minutes
20 – 15	20 to 15 minutes
15 – 10	15 to 10 minutes
10 – 5	10 to 5 minutes
5 – 0	5 to 2 minutes
5 – 0 (flashing)	2 to 0 minute

14 Audio level

These indicate the level of audio channel 1 and channel 2. The peak indication of the VTR level meter is related as follows to the audio level when an 1-kHz sine wave is input.

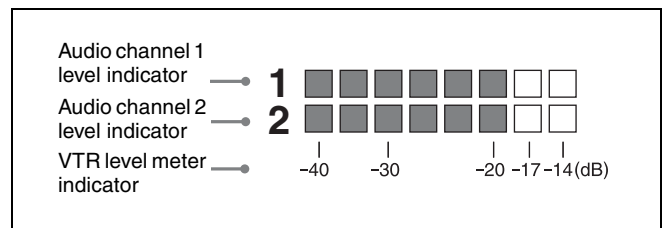
**15 Shutter speed**

This indicates the shutter speed or the shutter mode.

However, if the SHUTTER selector is set to OFF, nothing is displayed.

1/100 (MSW-970) or 1/60 (MSW-970P), 1/125, 1/250, 1/500, 1/1000, 1/2000: Shutter speed (in seconds) in standard mode

ECS: ECS mode

EVS: EVS mode

1F to 8F, 16F: Number of frames in SLS mode

16 Gain

This indicates the gain of the video amplifier, as set by the GAIN selector.

17 White balance memory

This indicates the currently selected white balance automatic adjustment memory.

- A:** Displayed when the WHITE BAL switch is set to A.
- B:** Displayed when the WHITE BAL switch is set to B.
- P:** Displayed when the WHITE BAL switch is set to PRST or when the preset button on the RM-B150/B750 has been pushed.
- T:** Displayed when ATW is being used.

18 Filter

This indicates the currently selected filter types.

19 D5600 indication

This appears when the electric 5600K color temperature filter function has been activated on the FUNCTION 2 page of the MAINTENANCE menu.

20 Time code

This indicates the time code, user bits or other information selected by the DISPLAY switch and DATA DISPLAY switch settings.

For more information, see “Relationships between the DISPLAY switch and DATA DISPLAY switch settings and the time counter displays” on page 32.

21 ID number

This indicates the ID number selected from ID 1 to ID 4. The ID number is recorded together with the color bars.

22 Date and time

This indicates the date and time of recording, which are recorded together with the color bars.

23 Model name and serial number

This indicates the model name and serial number of the camcorder, which are recorded together with the color bars.

24 16:9 mode

This indicates the 16:9 mode.

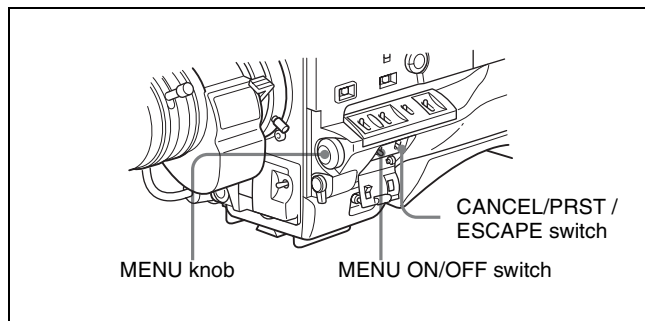

1 Set the MENU ON/OFF switch to ON.

The last accessed menu page appears on the viewfinder screen.

2 Turn the MENU knob until the VF DISP 1 or VF DISP 2 page appears, and press the MENU knob to select the page.

The current setting is displayed on the right of each item.

VF DISP 1 page

U040UF DISP 1		
→VF DISP	●	ON
VF DISP MODE	:	3
DISP EXTENDER	:	ON
DISP FILTER	:	ON
DISP WHITE	:	ON
DISP GAIN	:	ON
DISP SHUTTER	:	ON
DISP AUDIO	:	ON
DISP TAPE	:	ON
DISP IRIS	:	ON

You can select the following items to be displayed on the screen on the VF DISP 1 or VF DISP 2 page.

VF DISP 1 page

Item	Description
VF DISP	Turning on or off the viewfinder display ¹⁾
VF DISP MODE	Selecting the display mode ²⁾
DISP EXTENDER	Extender indicator
DISP FILTER	Types of the ND and CC filters
DISP WHITE	White balance memory indicator
DISP GAIN	Gain indicator
DISP SHUTTER	Shutter speed and ECS mode indicator
DISP AUDIO	Audio level indicator
DISP TAPE	Remaining tape indicator
DISP IRIS	Iris opening indicator

1) The viewfinder display can be also turned on or off by using the DISPLAY switch on the viewfinder.

2) For detailed information on the display mode, see “5-2-3 Display Modes and Setting Change Confirmation/Adjustment Progress Messages” on page 85.

5-2-2 Selecting the Display Items

To select the items to be displayed on the viewfinder screen from the VF DISP 1 and VF DISP 2 pages of the USER menu, turn on or off the indication next to each item.

To select the items to be displayed on the viewfinder screen, proceed as follows:

Item	Description
DISP ZOOM	Zoom position indicator
DISP COLOR TEMP.	Displays the color temperature.
DISP BATT REMAIN ¹⁾	Displays the battery voltage/remaining capacity of an internal battery pack or an external battery connected to the DC IN connector.
DISP DC IN	Displayed when the power is supplied from an external battery connected to the DC IN connector.
DISP 16:9/4:3 ID	Displays the 16:9/4:3 mode indicator.
DISP WRR RF LVL	Displays the reception level of the wireless microphone.
DISP E. MARK IND	Displayed when an essence mark has been recorded.
DISP TIME CODE	Displays the time code.
DISP VIDEO RATE	Displays the recording video signal rate.

1) When an Anton Bauer Intelligent Battery System or the BP-GL65/GL95/L60S battery pack is used, the setting of this item determines the display as follows:

INT: The remaining battery capacity is shown as a percentage when there is a change, and when the capacity is low.

AUTO: The remaining battery capacity is shown as a percentage, except that when this is impossible the battery voltage appears.

VOLT: The battery voltage is shown.

- 3** Turn the MENU knob to move the ➔ mark to the item you want to set, and press the MENU knob.

The ➔ mark on the left of the selected item changes to a ● mark, and the ● mark on the left of the setting changes to a ? mark.

- 4** Turn the MENU knob to select whether the selected item should appear in the viewfinder display (the “ON” setting), or not appear (the “OFF” setting), and press the MENU knob.

The ● mark returns to a ➔ mark, and the ? mark returns to a ● mark.

Note that pressing the CANCEL/PRST / ESCAPE switch to CANCEL/PRST on this page has no effect.

- 5** To set another item to “ON” or “OFF,” repeat steps **3** and **4**.
- 6** To end the menu operation, set the MENU ON/OFF switch to OFF or close the cover of the menu operating section.

The menu disappears from the viewfinder screen, and the display indicating the current status of the camcorder appears along the top and bottom of the screen.

5-2-3 Display Modes and Setting Change Confirmation/Adjustment Progress Messages

You can limit or suppress the messages that give details of setting changes and adjustment progress and results by setting a display mode.

The conditions under which messages are displayed and their correspondence with the display mode are as follows:

Setting change confirmation/adjustment progress messages and display modes

Y: Message is displayed.

N: Message is not displayed.

Message display condition	Message	Display mode setting		
		1	2	3
When the filter selection has been changed	ND : n, CC : m (where n = 1, 2, 3, 4, m = A, B, C, D)	N	N	Y
When the gain setting has been changed	GAIN : n (where n = -3 dB, 0 dB, 3 dB, 6 dB, 9 dB, 12 dB, 18 dB, 24 dB, 30 dB, 36 dB, 42 dB, 48 dB)	N	N	Y
When the setting of the WHITE BAL switch has been changed	WHITE : n (where n = A CH, B CH, PRESET) or ATW : RUN	N	N	Y
When the OUTPUT/DCC selector has been set to DCC ON or OFF	DCC : ON (or OFF)	N	Y	Y
When the shutter speed and mode setting has been changed ¹⁾	SS : 1/100 (MSW-970) or 1/60 (MSW-970P) (or 1/125, 1/250, 1/500, 1/1000, 1/2000, ECS, SLS)	N	Y	Y
When the black or white balance has been adjusted ²⁾	E.g. AWB : OK	N	Y	Y

1) This is also displayed for about 3 seconds when the SHUTTER selector is set to ON.

2) For details, see “4-1 Adjusting the Black Balance and the White Balance” on page 60.

Changing the display mode

The currently set display mode appears on the VF DISP 1 page of the USER menu. To change it, proceed as follows:

- 1** Follow steps **1** and **2** in “5-2-2 Selecting the Display Items” (page 84), until the VF DISP 1 page of the USER menu appears on the screen.

- 2 Turn the MENU knob to move the ➔ mark to “VF DISPLAY MODE,” and press the MENU knob.
The ➔ mark on the left of “VF DISPLAY MODE” changes to a ● mark, and the ● mark on the left of the setting changes to a ? mark.
- 3 Turn the MENU knob until the desired display mode appears, and press the MENU knob.
The ● mark returns to a ➔ mark, and the ? mark returns to a ● mark.
- 4 To end the menu operation, set the MENU ON/OFF switch to OFF or close the cover of the menu operating section.

5-2-4 Setting the Marker Display

Use the MARKER 1 page of the USER menu to switch the display of the center and safety zone markers on or off and to select whether the area indicated by the safety zone marker is 80%, 90% or 100% of the screen area.

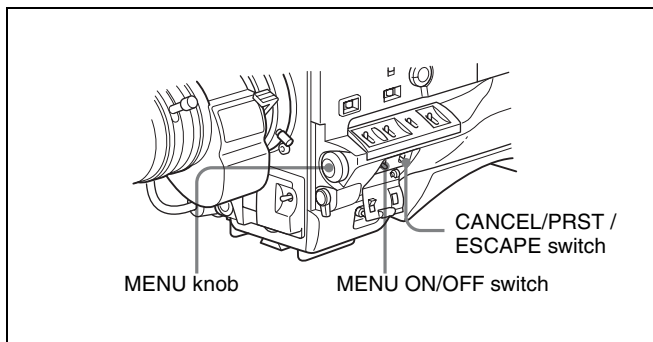

- 1 Set the MENU ON/OFF switch to ON.
The last accessed menu page appears on the viewfinder screen.
- 2 Turn the MENU knob until the MARKER 1 page appears, and press the MENU knob to select the page.
The current setting of each item appears on the right of the item.

MARKER 1 page

U070MARKER 1	TOP
➔MARKER	: ● OFF
CENTER	: OFF
SAFETY ZONE	: OFF
SAFETY AREA	: 90%
ASPECT	: OFF
ASPECT SELECT	: 4:3
ASPECT MASK	: OFF
ASPECT MASK LVL	: 1/4
100% MARKER	: OFF

You can set the following items on the MARKER 1 page.

Item	Description
MARKER	Not to display all markers, set to OFF.
CENTER	To display the center marker, set to ON.
SAFETY ZONE	To display the safety zone, set to ON.
SAFETY AREA	To select the safety zone range (80%, 90%, 92.5% or 95%), when SAFETY ZONE is set to ON.
ASPECT	To display the aspect marker, set to ON.
ASPECT SELECT	To select the type (4:3, 13:9, 14:9) of the aspect marker.
ASPECT MASK ¹⁾	To make the areas out of the selected aspect marker dimmer, set to ON.
ASPECT MASK LVL	To set the mask level (1/2, 1/4 or 1/8), when the ASPECT MASK is set to ON.
100% MARKER	To display the effective pixel area, set to ON.

1) The ASPECT MASK item is for processing the signal to be output to the viewfinder. When R, G, or B is selected for the TEST OUT SELECT item from the menu, the same video signal is output to the viewfinder and the TEST OUT connector. Thus, when the ASPECT MASK item is set to “ON” with R/G/B selected, the masked video signal is output to the TEST OUT connector.

- 3 Perform the settings for each item.
 - ① Turn the MENU knob to move the ➔ mark to the item you want to set, and press MENU knob.

The ➔ mark on the left of the selected item changes to the ● mark, and the ● mark on the left of the setting changes to a ? mark.
 - ② Turn the MENU knob to change the setting, and press the MENU knob.

The ● mark on the left of the selected item returns to a ➔ mark, and the ? mark on the left of the setting returns to a ● mark.
- 4 To continue setting other items, repeat step 3.
- 5 To end the menu operation, set the MENU ON/OFF switch to OFF or close the cover of the menu operating section.

The menu disappears from the viewfinder screen, and the display indicating the current status of the camcorder appears along the top and bottom of the screen.

5-2-5 Setting the Viewfinder

Use the VF SETTING page of the USER menu to select items related to the viewfinder.

Proceed as follows:

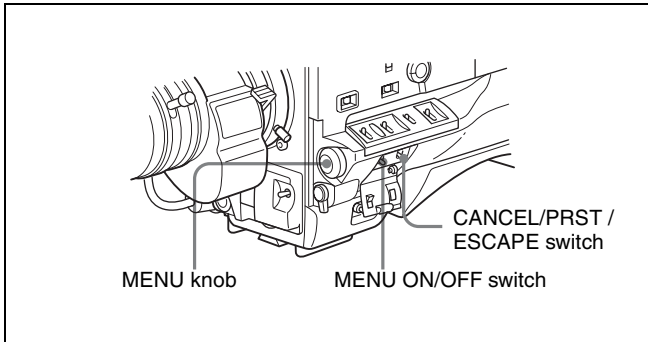

- 1** Set the MENU ON/OFF switch to ON.
The last accessed menu page appears on the viewfinder screen.
- 2** Turn the MENU knob until the VF SETTING page appears, and press the MENU knob to select the page.
The current setting of each item appears on the right of the item.

VF SETTING page

U09OVF SETTING	
→ZEBRA	: ● OFF
ZEBRA SELECT	: 1
ZEBRA1 DET. LEVEL	: 70%
ZEBRA1 APT. LEVEL	: 10%
ZEBRA2 DET. LEVEL	: 100%
VF DETAIL LEVEL	: OFF
VF ASPECT	: AUTO

Item	Description
ZEBRA	Turns the zebra display on or off. ¹⁾
ZEBRA SELECT	Selects ZEBRA 1, ZEBRA 2 or BOTH.
ZEBRA 1 DET. LVL	Adjusts the level of the zebra 1 (factory setting: 70%) display.
ZEBRA 1 APT. LVL	Adjusts the aperture level of the zebra 1 display (1 to 10 to 20).
ZEBRA 2 DET. LVL	Adjusts the level of the zebra 2 (factory setting: 100%) display.
VF DETAIL LEVEL	Adjusts the sharpness of the viewfinder. ²⁾ Turns the VF detail function on or off and adjusts the level.
VF ASPECT	Selects the viewfinder aspect ratio (AUTO/16:9). ³⁾

1) When you use the viewfinder which is not equipped with the ZEBRA switch, turns the display on or off using this item. When you use the viewfinder with the ZEBRA switch, the most recent operation of the ZEBRA switch and this menu operation is effective.
 2) The sharpness setting at the viewfinder does not affect the recorded image.
 3) When the VF ASPECT item is set to "AUTO," this is linked to the 16:9/4:3 selection on the FORMAT page.

- 3** Turn the MENU knob to move the ➔ mark to the item you want to set, and press the MENU knob.
The ➔ mark on the left of the selected item changes to a ● mark, and the ● mark on the left of the setting changes to a ? mark.
- 4** Turn the MENU knob to change the setting, and press the MENU knob.
The ● mark returns to a ➔ mark, and the ? mark returns to a ● mark.
- 5** To continue setting other items, repeat steps **3** and **4**.
- 6** To end the menu operation, set the MENU ON/OFF switch to OFF or close the cover of the menu operating section.

The menu disappears from the screen, and the display indicating the current status of the camcorder appears along the top and bottom of the screen.

5-2-6 Recording Shot Data Superimposed on the Color Bars

In the SHOT DISP page of the USER menu, you can select which shot data is recorded superimposed on the color bars. You can also select which of the shot IDs (1 to 4) set in the SHOT DATA page is recorded superimposed on the picture.

Proceed as follows:

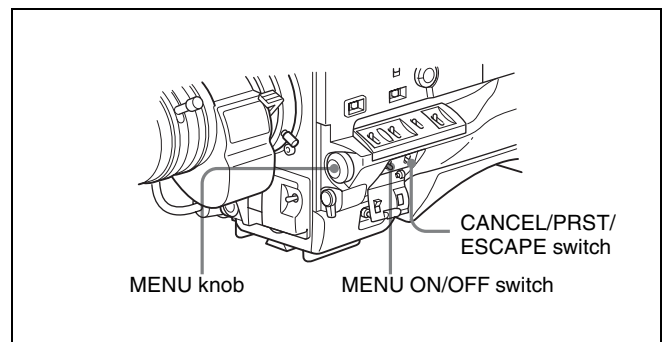

- 1** Set the MENU ON/OFF switch to ON.
The last accessed menu page appears on the viewfinder screen.
- 2** Turn the MENU knob until the SHOT DISP page appears, and press the MENU knob to select the page.
The current setting of each item appears on the right of the item.

SHOT DISP page

```

U120SHOT DISP
➔SHOT DATE      : ● OFF
SHOT TIME       : ● OFF
SHOT MODEL NAME : ● OFF
SHOT SERIAL NO  : ● OFF
SHOT ID SEL     : ● OFF
SHOT 16:9 ID   : ● OFF
SHOT BLINK CHARA: ● OFF
    
```

Item	Description
SHOT DATE	Selects whether or not the shot date is superimposed (ON or OFF).
SHOT TIME	Selects whether or not shot time is superimposed (ON or OFF).
SHOT MODEL NAME	Selects whether or not the model name is superimposed (ON or OFF).
SHOT SERIAL NO	Selects whether or not the serial number is superimposed (ON or OFF).
SHOT ID SEL	Selects whether or not the shot ID set on the SHOT ID ¹⁾ page is superimposed (1 to 4 or OFF).
SHOT 16:9 ID	Selects whether or not the 16:9 mode indicator is superimposed (ON or OFF).
SHOT BLINK CHARA	Selects whether or not the blinking * is superimposed (ON or OFF).

1) To carry out superimposed recording, select the SHOT ID number (1 to 4). Not to carry out superimposed recording, select "OFF."

- Turn the MENU knob to move the ➔ mark to the item you want to set, and press MENU knob.

The ➔ mark on the left of the selected item changes to a ● mark, and the ● mark on the left of the setting changes to a ? mark.

- Turn the MENU knob to select whether or not to record the selected item superimposed on the color bars, and press the MENU knob.

The ● mark on returns to a ➔ mark, and the ? mark returns to a ● mark.

- To continue setting other items, repeat steps 3 and 4.
- To end the menu operation, set the MENU ON/OFF switch to OFF or close the cover of the menu operating section.

Carrying out superimposed recording

To actually record the items selected for superimposed recording on the SHOT DISP page, set the OUTPUT/DCC switch to BARS, DCC OFF.

The items selected for superimposed recording appear on the screen and are recorded superimposed on the color bars.

5-2-7 Setting the Shot ID

On the SHOT ID page of the USER menu, you can set a shot ID of up to 12 alphanumeric characters, spaces, and symbols.

When the OUTPUT/DCC switch is set to BARS, DCC OFF, this shot ID is output with the color bar signal. The shot ID comprises ID1 to ID4, and the setting can be changed using the SHOT DISP page of the USER menu. You can select the SHOT ID to be recorded superimposed on the color bars on the SHOT DISP page.

Note

When the menu is displayed, the shot ID is not displayed even if the color bar signal is output.

To set the shot ID, proceed as follows:

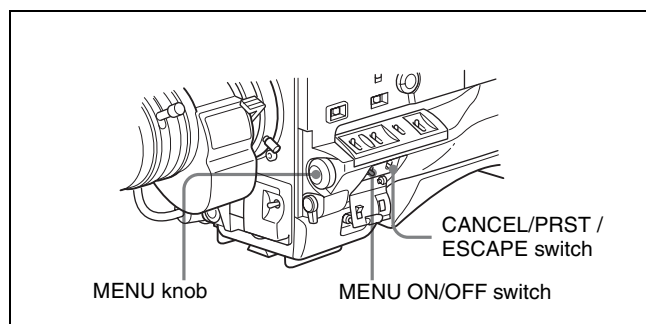

- Set the MENU ON/OFF switch to ON.
The last accessed menu page appears on the screen.
- Turn the MENU knob until the SHOT ID page appears, and press the MENU knob to select the page.

SHOT ID page

```

U110SHOT ID TOP
➔ID-1 : ● □ □ □ □ □ □ □ □ □ □ □ □
ID-2  : □ □ □ □ □ □ □ □ □ □ □ □
ID-3  : □ □ □ □ □ □ □ □ □ □ □ □
ID-4  : □ □ □ □ □ □ □ □ □ □ □ □
    
```

- Turn the MENU knob to move the ➔ mark to the ID (one of ID-1 to ID-4) you want to set, and press the MENU knob.

A ■ mark appears over the first character position in the string, and characters can now be input.

```

U110SHOT ID TOP
●ID-1 : ? ■ □ □ □ □ □ □ □ □ □ □ □ □
ID-2  : □ □ □ □ □ □ □ □ □ □ □ □
ID-3  : □ □ □ □ □ □ □ □ □ □ □ □
ID-4  : □ □ □ □ □ □ □ □ □ □ □ □

!#$%&'()*+,-./012345678
9:;<=>?@ABCDEFGHIJKLMNPO
QRSTUVWXYZ[*]abcdefghijklmnop
lmnopqrstuvwxyz~
INS DEL RET ESC END
    
```

FUNCTION window

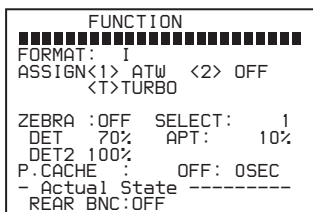

This window allows you to confirm the assigned function of the ASSIGN 1/2 switches, ON/OFF of the Picture Cache function, and ON/OFF of the output of the VIDEO OUT connector.

AUDIO STATUS window

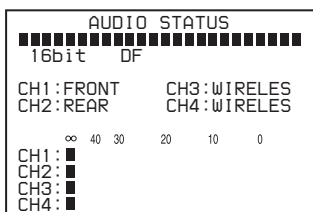

This window allows you to confirm the following items related to audio.

- Audio data length
- DF/NDF setting (only for the MSW-970)
- Type of input signal to audio channels 1 to 4
- Input level of audio channels 1 to 4

You can use the SET STATUS page of the USER menu to set whether or not the status confirmation windows are displayed.

Displaying the status confirmation windows

You can use the CANCEL/PRST / ESCAPE switch as the STATUS ON/SEL / OFF switch when the MENU ON/OFF switch is set to OFF (when the cover of the menu operating section is closed, OFF is automatically selected).

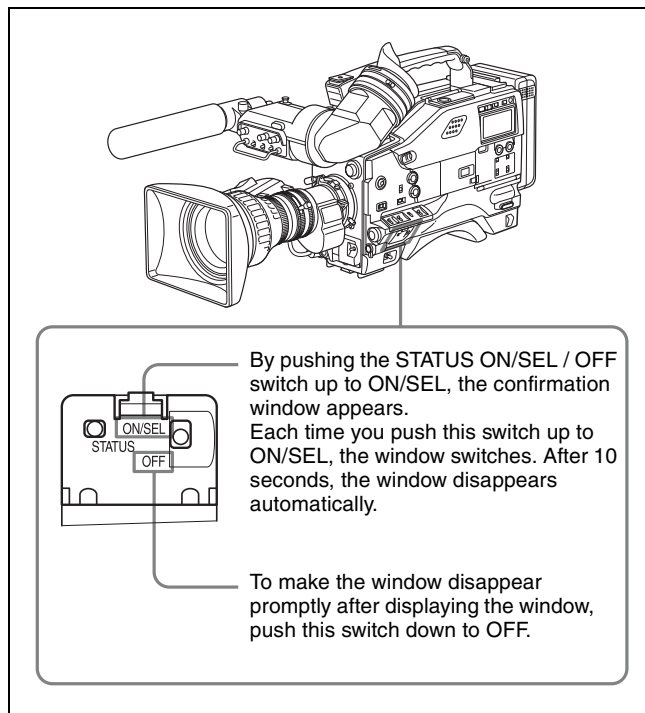

Disabling display of the status confirmation windows

Proceed as follows:

- 1 Set the MENU ON/OFF switch to ON.
The last accessed menu page appears on the viewfinder screen.
- 2 Turn the MENU knob until the SET STATUS page appears, and press the MENU knob to select the page.
The current setting of each item appears on the right of the item.

SET STATUS page

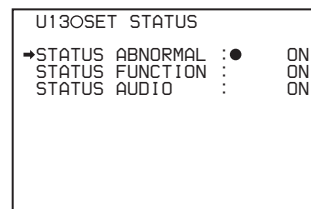

Item	Description
STATUS ABNORMAL	Selects whether or not the ABNORMAL window is displayed (ON or OFF).
STATUS FUNCTION	Selects whether or not the FUNCTION window is displayed (ON or OFF).
STATUS AUDIO	Selects whether or not the STATUS AUDIO window is displayed (ON or OFF).

- Turn the MENU knob to move the ➔ mark to the item you want to set, and press MENU knob.

The ➔ mark on the left of the selected item changes to a ● mark, and the ● mark on the left of the setting changes to a ? mark.

- Turn the MENU knob to select whether or not to display the selected window, then press the MENU knob.

The ● mark returns to a ➔ mark, and the ? mark returns to a ● mark.

- To continue setting other windows, repeat steps 3 and 4.

- To end the menu operation, set the MENU ON/OFF switch to OFF or close the cover of the menu operating section.

5-2-9 Confirming the Image of the Return Video Signal in the Viewfinder

You can set whether or not to see the image of the return video signal in the viewfinder, using the GENLOCK page of the MAINTENANCE menu.

Proceed as follows:

- Set the MENU ON/OFF switch to ON while holding down the MENU knob.

The TOP menu appears.

- Turn the MENU knob to move the ➔ mark to “MAINTENANCE,” then press the MENU knob.

If this is the first time the MAINTENANCE menu has been displayed, the CONTENTS page of the MAINTENANCE menu appears.

If the menu has been used before, the last accessed page appears.

- If the CONTENTS page is displayed, turn the MENU knob to move the ➔ mark to “GENLOCK,” then press the MENU knob to display the GENLOCK page. If a different page is displayed, turn the MENU knob until the GENLOCK page appears, then press the MENU knob to select the page.

The current setting of each item appears on the right of the item.

GENLOCK page

M160GENLOCK			
GENLOCK	:	ON	
RETURN VIDEO	:	OFF	
GL H PHASE	:	0	
GL SC PHASE	:	0	
GL SC 0/180 SEL	:	180	

- Carry out setting operations as follows:

- Turn the MENU knob to move the ➔ mark to “GENLOCK,” and press the MENU knob.

The ➔ mark on the left of “GENLOCK” changes to a ● mark, and the ● mark on the left of the GENLOCK setting changes to a ? mark.

- Turn the MENU knob until “OFF” appears, then press the MENU knob.

The ● mark returns to a ➔ mark, and the ? mark returns to a ● mark, and the setting is executed.

- Turn the MENU knob to move the ➔ mark to “RETURN VIDEO,” and press the MENU knob.

The ➔ mark changes to a ● mark, and the ● mark changes to a ? mark.

- Turn the MENU knob until “ON” appears, then press the MENU knob.

The ● mark returns to a ➔ mark, and the ? mark returns to a ● mark, and the setting is executed.

- To end the menu operation, set the MENU ON/OFF switch to OFF or close the cover of the menu operating section.

To see the image of the return video signal on the viewfinder screen

Hold down the RET switch on the lens. The image of the return video signal input to the GENLOCK IN connector is displayed on the viewfinder screen while you are holding down the RET switch.

When the return video function is assigned to the ASSIGN 1 switch, you can see the image of the return video signal on the viewfinder screen while you are holding down the ASSIGN 1 switch even if the RETURN VIDEO item is set to “OFF” on the GENLOCK page of the MAINTENANCE menu.

Note

When no signal is input to the GENLOCK IN connector, the image is not changed even if you hold down the RET switch on the lens.

However, the image is switched while you are holding down the ASSIGN 1 switch to which the return video function is assigned, even if no signal is input to the GENLOCK IN connector.

5-3 Adjustments and Settings from Menus

The camcorder provides menus for adjustments and settings.

5-3-1 Setting Gain Values for the GAIN Selector Positions

Before using the camcorder, use the GAIN SW page of the USER menu to set the gains corresponding to the L, M, and H positions of the GAIN selector, which switches the gain of the video amplifier.

To set the gain values, proceed as follows:

- 1** Set the MENU ON/OFF switch to ON.
The last accessed menu page appears on the viewfinder screen.
- 2** Turn the MENU knob until the GAIN SW page appears, then press the MENU knob to select the page.
The current setting of each item appears on the right of the item.

GAIN SW page

U080GAIN SW	TOP
→GAIN LOW	: ● 0db
GAIN MID	: 9db
GAIN HIGH	: 18db
GAIN TURBO	: 42db
TURBO SW IND	: OFF

Item	Description
GAIN LOW	Sets the gain value corresponding to the L position of the GAIN selector.
GAIN MID	Sets the gain value corresponding to the M position of the GAIN selector.
GAIN HIGH	Sets the gain value corresponding to the H position of the GAIN selector.
GAIN TURBO	Sets the gain value corresponding to TURBO GAIN button selection.

Item	Description
TURBO SW IND	<p>OFF: When you operate the GAIN selector after pressing the TURBO GAIN button once, the video gain is changed according to the GAIN selector operation.</p> <p>ON: When the video gain is boosted to the video gain to the value preset by pressing the TURBO GAIN button once, the video gain is not changed even if you operate the GAIN selector, until you press the TURBO GAIN button once more.</p>

- Turn the MENU knob to move the ➔ mark to the item you want to set, and press MENU knob.

The ➔ mark on the left of the selected item changes to a ● mark, and the ● mark on the left of the setting changes to a ? mark.

- Turn the MENU knob to change the setting, and press the MENU knob.

The ● mark on the left of the selected item returns to a ➔ mark, and the ? mark on the left of the setting returns to a ● mark.

Any of -3, 0, 3, 6, 9, 12, 18, 24, 30, 36, 42 or 48 dB can be set for each of the L, M, and H positions, in any sequence.

For TURBO, any of -3, 0, 3, 6, 9, 12, 18, 24, 30, 36, 42 or 48 dB can be selected.

To change the gain corresponding to another switch position, return to step 3.

- To end the menu operation, set the MENU ON/OFF switch to OFF or close the cover of the menu operating section.

The menu display disappears, and the current status of the camcorder is shown along the top and bottom of the viewfinder screen.

5-3-2 Selecting the Output Signals

When the optional CBK-SD01 extension board is installed, you can select the type of video signals (VBS/SDI) from the VIDEO OUT SEL connector on the OUTPUT SEL page of the USER menu.

Proceed as follows:

- Set the MENU ON/OFF switch to ON.

The last accessed menu page appears on the viewfinder screen.

- Turn the MENU knob until the OUTPUT SEL page appears, then press the MENU knob to select the page.

OUTPUT SEL page

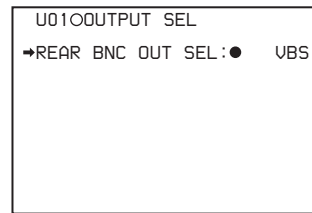

Item	Description
REAR BNC OUT SEL	<p>Selects the type of the video signal to be output from the VIDEO OUT connector.</p> <p>SDI: Outputs the SDI signal. When SDI is selected, connect the VIDEO OUT connector to the SDI IN connector of the video monitor.</p> <p>VBS: Outputs the analog composite video signal. When VBS is selected, connector the VIDEO OUT connector to the VIDEO IN connector of the video monitor.</p>

- Turn the MENU knob to move the ➔ mark to “REAR BNC OUT SEL,” and press the MENU knob.

The ➔ mark on the left of “REAR BNC OUT SEL” changes to a ● mark, and the ● mark on the left of the setting changes to a ? mark.

- Turn the MENU knob to change the desired setting, and press the MENU knob.

The ● mark returns to a ➔ mark, and the ? mark on the left of the setting returns to a ● mark.

- To end the menu operation, set the MENU ON/OFF switch to OFF or close the cover of the menu operating section.

5-3-3 Setting the Color Temperature Manually

You can adjust the value of the white balance manually by setting the color temperature.

Proceed as follows:

- Holding down the MENU knob, move the MENU ON/OFF switch to ON.

The TOP menu appears.

- Turn the MENU knob to move the ➔ mark to “PAINT,” and press the MENU knob.

If this is the first time the PAINT menu has been displayed, the CONTENTS page appears. If the menu has been used before, the last accessed page appears.

- 3 If the CONTENTS page is displayed, turn the MENU knob to move the ➔ mark to “WHITE,” and press the MENU knob to display the WHITE page. If a different page is displayed, turn the MENU knob until the WHITE page appears, and press the MENU knob to select the page.

The current setting of each item appears on the right of the item.

WHITE page

```

P020WHITE
➔COLOR TEMP <A>: ● 3200
COLOR FINE <A>: 0
R GAIN <A>: 0
B GAIN <A>: 0
D5600K <A>: OFF
COLOR TEMP <B>: 3200
COLOR FINE <B>: 0
R GAIN <B>: 0
B GAIN <B>: 0
D5600K : OFF
  
```

Item	Description
COLOR TEMP <A>	Sets the color temperature for the desired value. Adjust the value while looking at the real image because error tends to be bigger for adjustment of high color temperature.
COLOR FINE <A>	Adjusts the value more precisely when the color temperature adjustment through COLOR TEMP is not satisfactory.
R GAIN <A>	Only the value of R GAIN is changed.
B GAIN <A>	Only the value of B GAIN is changed.
D5600K	Sets the color temperature to approximately 5600K.

The above table shows the adjustment of the white balance of channel A. Items followed by “” are used to adjust the white balance of channel B.

- 4 Turn the MENU knob to move the ➔ mark to the item you want to set, and press MENU knob.
- 5 Turn the MENU knob to change the setting, and press the MENU knob.

The ➔ mark on the left of the selected item changes to a ● mark, and the ● mark on the left of the setting changes to a ? mark.

The ● mark returns to a ➔ mark, and the ? mark returns to a ● mark.

To set other items, go back to step 3.

- 6 To end the menu operation, set the MENU ON/OFF switch to OFF or close the cover of the menu operating section.

5-3-4 Specifying an Offset for the Auto White Balance Setting

By setting an offset for the value of auto white balance, you can make the picture warmer or colder. The OFFSET WHT page of the OPERATION menu allows you to do this setting.

Proceed as follows:

- 1 Holding down the MENU knob, move the MENU ON/OFF switch from OFF to ON.
- 2 Turn the MENU knob to move the ➔ mark to “OPERATION,” and press the MENU knob.

The TOP menu appears.

If this is the first time the OPERATION menu has been displayed, the CONTENTS page appears. If the menu has been used before, the last accessed page appears.

- 3 If the CONTENTS page is displayed, turn the MENU knob to move the ➔ mark to “OFFSET WHITE,” and press the MENU knob to display the OFFSET WHT page. If a different page is displayed, turn the MENU knob until the OFFSET WHT page appears, and press the MENU knob to select the page.

The current settings of each item appears on the right of the item.

OFFSET WHT page

```

1600OFFSET WHT
➔OFFSET WHITE <A>: ● OFF
WARM COOL <A>: 3200
COLOR FINE <A>: 0

OFFSET WHITE <B>: OFF
WARM COOL <B>: 3200
COLOR FINE <B>: 0
  
```

Item	Description
OFFSET WHITE <A>	Turns the setting of the offset for channel A ON or OFF. ON: Adds the offset adjusted on this page to the white balance.
WARM-COOL <A>	When OFFSET WHITE <A> is ON, sets the offset for the white balance of channel A, using the color temperature. Adjust the value while looking at the real image because error tends to be bigger for adjustment of high color temperature.

Item	Description
COLOR FINE <A>	Adjusts the value more precisely if the adjustment by WARM-COOL <A> is not satisfactory.
OFFSET WHITE 	Turns the setting of the offset for channel B ON or OFF. ON: Adds the offset adjusted on this page to the white balance.
WARM-COOL 	Sets the offset for the white balance of channel B, using the color temperature. Adjust the value while looking at the real image because error tends to be bigger for adjustment of high color temperature.
COLOR FINE 	Adjusts the value more precisely if the adjustment by WARM-COOL is not satisfactory.

- 4** Set the WHITE BAL switch to the position corresponding to the desired channel (A or B).

Note

If the WHITE BAL switch is not set to A or B when you operate the camcorder, the adjustment value will not be reflected in the output signal.

- 5** Turn the MENU knob to move the ➔ mark to the item you want to set, and press MENU knob.

The ➔ mark on the left of the selected item changes to a ● mark, and the ● mark on the left of the setting changes to a ? mark.

- 6** Turn the MENU knob to change the setting, and press the MENU knob.

The ● mark returns to a ➔ mark, and the ? mark returns to a ● mark.

To set other items, go back to step **3**.

To set the other white balance channel, go back to step **2**.

- 7** To end the menu operation, set the MENU ON/OFF switch to OFF or close the cover of the menu operating section.

Note

When using the OFFSET WHITE function, “+” is displayed as the WARM color temperature indication and “-” is displayed as the COOL temperature indication in the viewfinder.

5-3-5 Assigning Functions to Assignable Switches

You can assign the desired function to the ASSIGN 1/2 switches and the TURBO GAIN button.

Proceed as follows:

- 1 Set the MENU ON/OFF switch to ON.
The last accessed menu page appears on the viewfinder screen.
- 2 Turn the MENU knob until the FUNCTION 1 page appears, then press the MENU knob to select to page.

The current settings of each item appears on the right of the item.

FUNCTION 1 page

?U03OFUNCTION1	
ASSIGN SW <1>	: ATW
ASSIGN SW <2>	: OFF
TURBO SW	: TURBO
DF/NDP	: DF
END SEARCH	: OFF
CACHE/INTVAL REC	: OFF

Item	Description
ASSIGN SW <1>	Assigns the function to ASSIGN 1 (push-type) switch.
ASSIGN SW <2>	Assigns the function to ASSIGN 2 (slide-type) switch.
TURBO SW	Assigns the function to the TURBO GAIN button.

- 3** Turn the MENU knob to move the ➔ mark to the item corresponding to the switch to which you want to assign the function, and press the MENU knob.

The corresponding ASSIGN SEL window appears.

ASSIGN <1> SEL window

ASSIGN <1> SEL ESC	
↓ ↓	
→ OFF	
PICTURE CACHE ON/OFF	
TEST OUT CHARACTER	
MARKER	
RE-TAKE	
ATW	
RETURN VIDEO	
LENS RET	
REC SWITCH	
TURBO SWITCH	

ASSIGN <2> SEL window

ASSIGN <2> SEL ESC
↕
↕
→OFF
PICTURE CACHE ON/OFF
TEST OUT CHARACTER
MARKER
REC VIDEO SOURCE
ZEBRA
D5600
EXT REC CONTROL

TURBO SW SEL window

TURBO SW SEL ESC
↕
↕
→OFF
PICTURE CACHE ON/OFF
TEST OUT CHARACTER
MARKER
RE-TAKE
ATW
RETURN VIDEO
LENS RET
REC SWITCH
TURBO SWITCH

Functions to be assigned to the ASSIGN 1 (push-type) switch and TURBO GAIN button

Function	Description
OFF	Disables the switch.
PICTURE CACHE ON/OFF ¹⁾	Assigns Picture Cache mode ON/OFF function.
TEST OUT CHARACTER	Assigns the function to switch whether or not text is superimposed on the video signal to be output from the TEST OUT connector.
MARKER	Assigns the ON/OFF function to display all markers. ²⁾
RE-TAKE	Assigns the RE-TAKE function.
ATW	Assigns the ON/OFF function of auto-tracing white balance.
RETURN VIDEO	Assigns the ON/OFF function to display the image of the return video signal on the viewfinder. ³⁾
LENS RET	Assigns the same function as that of the RET switch on the lens.
REC SWITCH	Assigns the VTR S/S (start/stop) function.
TURBO SWITCH	Assigns the turbo gain function.
TELE-FILE MARK	Assigns the function to record shot marks (OK/NG/KP).
ZEBRA	Assigns the zebra pattern display function.
D5600	Applies an electrical 5600K filter.
UA01 to UA10 ⁴⁾	Assigns the items assigned in the ASSIGN SEL menu.

- 1) This does not appear if the MSDW-903 is not installed.
- 2) Even when the MARKER item is set to "OFF" on the MARKER page of the USER menu, the ASSIGN 1 switch (or TURBO GAIN button) allows you to display or not to display all markers.

- 3) Even if the RETURN VIDEO item is set to "OFF" on the GENLOCK page of the MAINTENANCE menu, you can use this switch to display the image of the return video signal on the viewfinder.
- 4) This does not appear if nothing is assigned in the Assign menu.

Functions to be assigned to the ASSIGN 2 (slide-type) switch

Function	Content
OFF	Disables the switch.
PICTURE CACHE ON/OFF ¹⁾	Assigns Picture Cache mode ON/OFF function.
TEST OUT CHARACTER	Assigns the function to switch whether or not the characters are mixed to the video signal to be output from the TEST OUT connector.
MARKER	Assigns the ON/OFF function to display all markers. ²⁾
REC VIDEO SOURCE ³⁾	Selects which signals you will record pictures being shot by the camcorder or video signals from external equipment connected to GENLOCK IN connector.
ZEBRA	Assigns the zebra pattern display function.
D5600	Applies an electrical 5600K filter.
EXT REC CONTROL	Selects whether or not recording control of external devices connected through the CCZ connector (26-pin) of a CA-702 is possible.
UA01 to UA10 ⁴⁾	Assigns the items assigned in the ASSIGN SEL menu.

- 1) This does not appear if the MSDW-903 is not installed.
- 2) Even when the MARKER item is set to "OFF" on the MARKER page of the USER menu, the ASSIGN 2 switch allows you to display or not to display all markers.
- 3) This does not appear if the MSDW-904 is not installed.
- 4) This does not appear if nothing is assigned in the Assign menu.

Note

For functions that are assigned to the ASSIGN 2 (slide-type) switch, you cannot change those settings using other menus. The function assigned to ASSIGN 2 switch takes precedence over the menu setting.

- 4 Turn the MENU knob to move the ➔ mark to the item you want to set, and press MENU knob.

The ➔ mark changes to a ● mark, and the ● mark by the setting changes to a ? mark.

- 5 Turn the MENU knob to switch to the desired setting, and press the MENU knob.

The ● mark returns to a ➔ mark, and the ? mark returns to a ● mark, confirming the setting.

- 6 To continue with other settings, repeat steps 3 and 4.

To return to the previous page

Turn the MENU knob to move the ➔ mark to “ESC” at the right top of the window and press the MENU knob. Alternatively, push the CANCEL/PRST / ESCAPE switch down to the ESCAPE side.

To end the menu operation

Set the MENU ON/OFF switch to OFF or close the cover of the menu operating section.

Operation of the assignable switches when UA01 to UA10 are assigned

When an on/off switchable function (or menu item) is assigned to one of the assignable switches, each time the switch is pressed toggles the function on or off. When another type of menu item is assigned, pressing the switch displays the item and its setting value on the viewfinder screen.

You can then change the setting by pressing and turning the MENU knob.

The viewfinder screen display disappears approximately 3 seconds after the last operation.

5-3-6 Setting the Date/Time of the Internal Clock

You can set or change the date and time of the internal clock. The date and time set are reflected in the time code.

Proceed as follows:

- 1 Holding down the MENU knob, move the MENU ON/OFF switch to ON.

The TOP menu appears.

- 2 Turn the MENU knob to move the ➔ mark to “DIAGNOSIS,” and press the MENU knob.

If this is the first time the DIAGNOSIS menu has been displayed, the CONTENTS page appears. If the menu has been used before, the last accessed page appears.

- 3 If the CONTENTS page is displayed, turn the MENU knob to move the ➔ mark to “TIME/DATE,” and press the MENU knob to display the TIME/DATE page. If a different page is displayed, turn the MENU knob until the TIME/DATE page appears, then press the MENU knob to select the page.

The ➔ mark is displayed at “ADJUST.”

TIME/DATE page

D020TIME/DATE		
➔ADJUST	:D	EXEC
HOUR	:	12
MIN	:	55
SEC	:	58
YEAR	:	00
MONTH	:	07
DAY	:	31

- 4 Press the MENU knob.

The TIME ADJUST setting window appears.

TIME ADJUST ESC		
HOUR	:	12
MIN	:	55
SEC	:	58
YEAR	:	00
MONTH	:	07
DAY	:	31
OK		

Item	Description
HOUR	Sets the hour value.
MIN	Sets the minutes value.
SEC	Sets the seconds value.
YEAR	Sets the year.
MONTH	Sets the month.
DAY	Sets the day.

- 5 Turn the MENU knob to move the ➔ mark to the item you want to set, and press MENU knob.

The ➔ mark on the left of the selected item changes to a ● mark, and the ● mark on the left of the setting changes to a ? mark.

- 6 Turn the MENU knob to display the desired value, and press the MENU knob.

The ● mark returns to a ➔ mark, and the ? mark returns to a ● mark.

- 7 To continue the remaining settings, repeat steps 5 and 6.

- 8 When you finish settings, turn the MENU knob to move the ➔ mark to “OK,” then press the MENU knob.

The internal clock is set with the date and time set in steps 5 to 7. The TIME/DATE page of the DIAGNOSIS menu appears again. The time set on the TIME ADJUST setting window is displayed.

To cancel the setting

Before executing step 8, move the ➔ mark to “ESC” at the top right of the window and press the MENU knob. Alternatively, push the CANCEL/PRST / ESCAPE switch down to the ESCAPE side.

All settings or changes are discarded and the TIME/DATE page of the DIAGNOSIS menu appears.

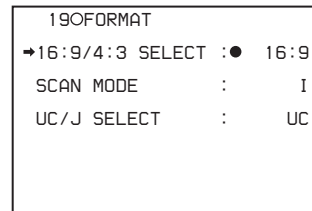

("UC/J SELECT" is displayed only for the MSW-970.)

5-3-7 Selecting the Lens File

The LENS FILE page of the USER menu allows you to change the lens file according to the lens in use.

Proceed as follows:

- 1 Set the MENU ON/OFF switch to ON.
The last accessed menu page appears on the viewfinder screen.
- 2 Turn the MENU knob until the LENS FILE page appears, then press the MENU knob to select the page.
The LENS FILE page shows the lens name and the f-stop (iris setting) of the lens file currently selected.

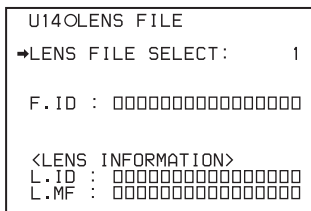

- 3 Turn the MENU knob to move the ➔ mark to LENS FILE SELECT, and press the MENU knob.
The ➔ mark changes to a ● mark, and the ● mark changes to a ? mark.
- 4 Turn the MENU knob until the lens file No. in use appears, then press the MENU knob.
The ● mark returns to a ➔ mark, and the ? mark returns to a ● mark.
- 5 To end the menu operation, set the MENU ON/OFF switch to OFF or close the cover of the menu operating section.

- 2 Turn the MENU knob to move the ➔ mark to "16:9/4:3 SELECT," and press MENU knob.

The ➔ mark on the left of the selected item changes to a ● mark, and the ● mark on the left of the setting changes to a ? mark.

- 3 Turn the MENU knob to display the desired aspect ratio, and press the MENU knob.

The ● mark returns to a ➔ mark, and the ? mark returns to a ● mark.

- 4 To end the menu operation, set the MENU ON/OFF switch to OFF or close the cover of the menu operating section.

To display the aspect ratio of 16:9/4:3 on the viewfinder screen

By setting the "DISP 16:9/4:3 ID" item on the VF DISP 2 page of the USER menu to "ON," "16:9" or "4:3" appears on the viewfinder screen according to the setting on the FORMAT page.

For details, see "5-2-2 Selecting the Display Items" on page 84.

To display "16:9" in color bars

By setting the "SHOT 16:9 ID" on the SHOT DISP page of the USER menu to ON, you can record a "16:9" mode indicator superimposed on the color bars.

For details, see "5-2-6 Recording Shot Data Superimposed on the Color Bars" on page 87.

5-3-8 Selecting the Aspect Ratio

The FORMAT page of the OPERATION menu allows you to select the aspect ratio of the video output signal.

Proceed as follows:

- 1 Follow the procedure of steps 1 to 3 described in "5-3-4 Specifying an Offset for the Auto White Balance Setting" on page 94 to display the FORMAT page of the OPERATION menu.

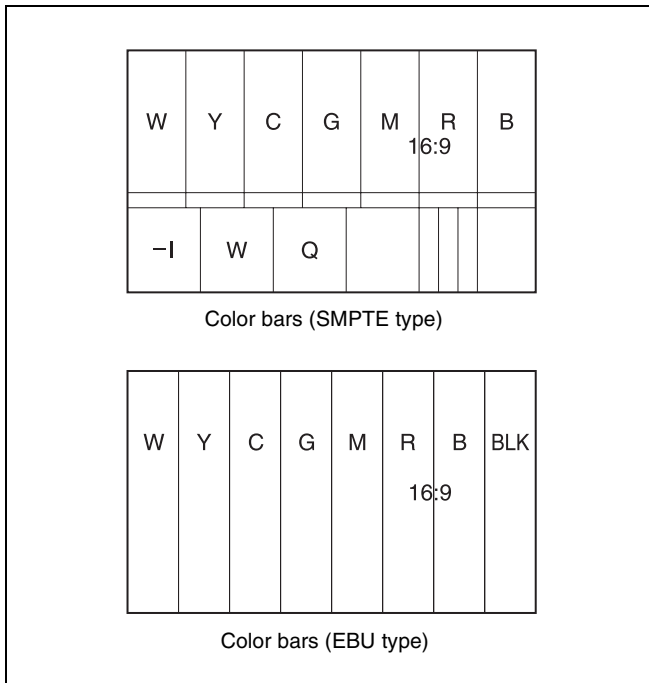

16:9 mode indicator on the color bar display

5-3-9 Setting the CCD Scan Mode

Since the camcorder has CCDs that use an “all pixels read-out method,” a progressive scan mode is also available in addition to the conventional interlace scan mode.

You can select either of the following modes using the FORMAT page of the OPERATION menu.

- I (interlace scan) mode
- PsF (progressive scan) mode

Installing the CBK-FC01 allows you to select the 24P mode (MSW-970 only).

Each mode is described below using timing charts.

I (interlace scan) mode

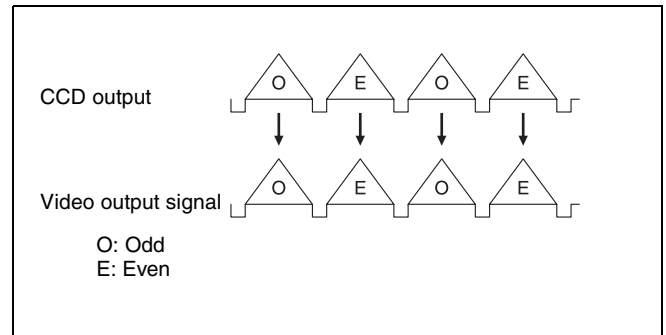

Interlace scan mode timing chart

The video signal of an odd scanning line and that of an even scanning line are output from the CCD alternately. Thus, the timing of the odd-field video signal and even-field video signal are different.

PsF (progressive scan) mode

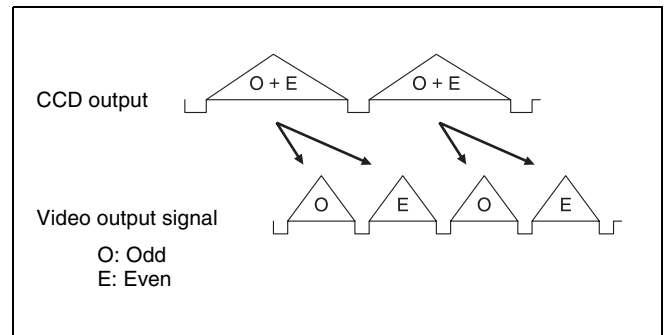

Progressive scan mode timing chart

The video signal of an odd scanning line and that of an even scanning line are output from the CCD at the same time. Then they are sent to the memory and separated into odd-field and even-field scanning lines. Thus the timing of an odd-field video signal and an even-field video signal are the same.

24P (pull-down) mode (MSW-970 with CBK-FC01 only)

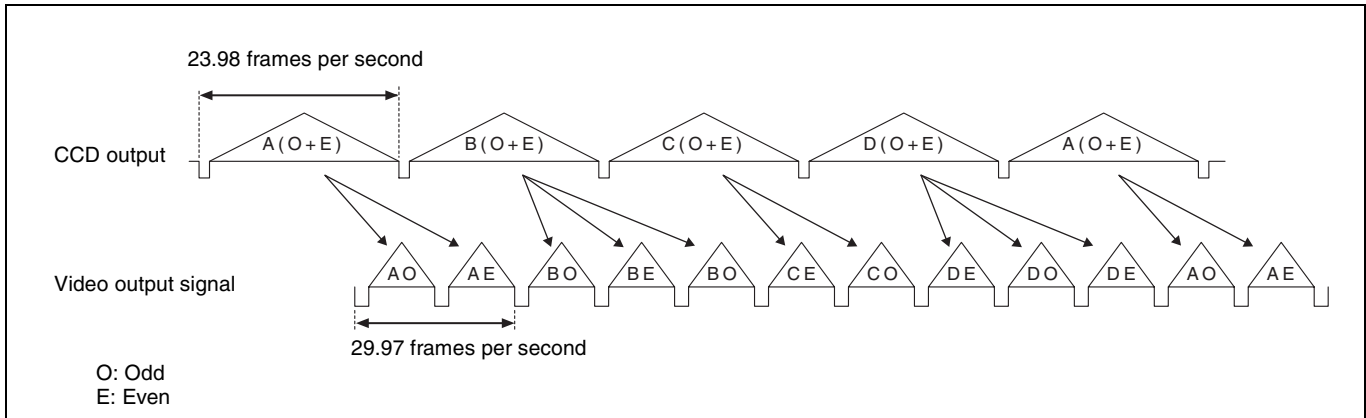

24P mode timing chart

After reading from the CCDs in 24P mode (23.98 frames per second), a pull-down conversion is carried out to the 30 frames (29.97 frames per second) of the normal progressive scan mode.

Setting the CCD scan mode to the progressive scan mode

The scan mode of the camcorder has been set to the interlace scan mode at the factory. The FORMAT page of the OPERATION menu allows you to change the CCD scan mode to the progressive scan mode or 24P mode (MSW-970 with CBK-FC01 only).

- 1 Follow the procedures given in steps 1 to 3 described in “5-3-4 Specifying an Offset for the Auto White Balance Setting” on page 94, to display the FORMAT page of the OPERATION menu.
- 2 Turn the MENU knob to move the ➔ mark to “SCAN MODE,” and press the MENU knob.

The ➔ mark on the left of “SCAN MODE” changes to a ● mark, and the ● mark on the left of the setting changes to a ? mark.

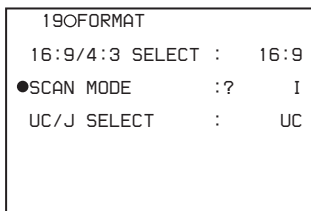

(“UC/J SELECT” is displayed only for the MSW-970.)

- 3 Turn the MENU knob to display “PsF” or “24P,” and press the MENU knob.

The ● mark changes to a ➔ mark, and the ? mark changes to a ● mark.

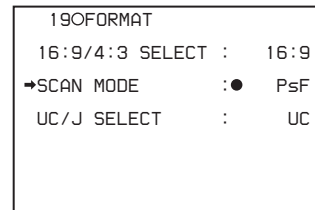

- 4 To end the menu operation, set the MENU ON/OFF switch to OFF.

Note

When the CBK-FC01 is connected, “V LPF (24P/30P) OFF/ON” is displayed under “SCAN MODE” on the menu. With this function set to “ON,” flicker in the vertical direction of horizontal/slanted lines in PsF/24P mode will be decreased (default is “ON”).

5-3-10 Using UMID Data

To perform operations from interviewing to editing effectively and to detect audio-visual materials easily when reusing them, metadata that provides additional information is recorded along with audio-visual data on a tape. As one of application of metadata, the UMID (Unique Material Identifier) is internationally standardized.

What is a UMID?

The UMID (Unique Material Identifier) is a unique identifier for audio-visual material defined by the SMPTE330M-2003 standard.

The UMID may be used either as the 32-byte Basic UMID or as the Extended UMID, which includes an additional 32 bytes of Source Pack to make a total 64 bytes.

For details, refer to SMPTE 330M.

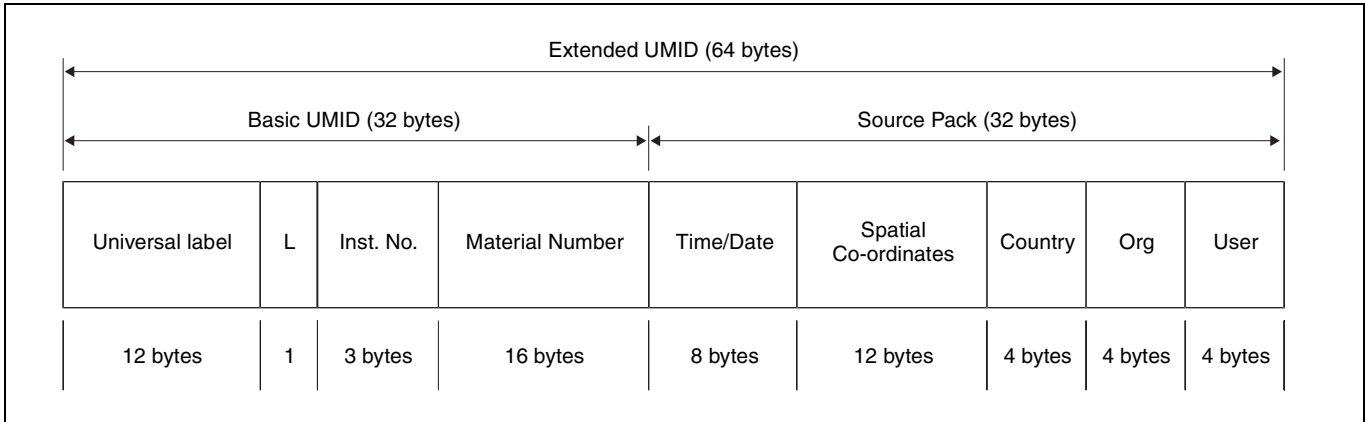

Globally unique ID is automatically recorded every shooting.

The Extended UMID is metadata that provides additional information such as location, time/date, company and so on.

The UMID is applied as follows:

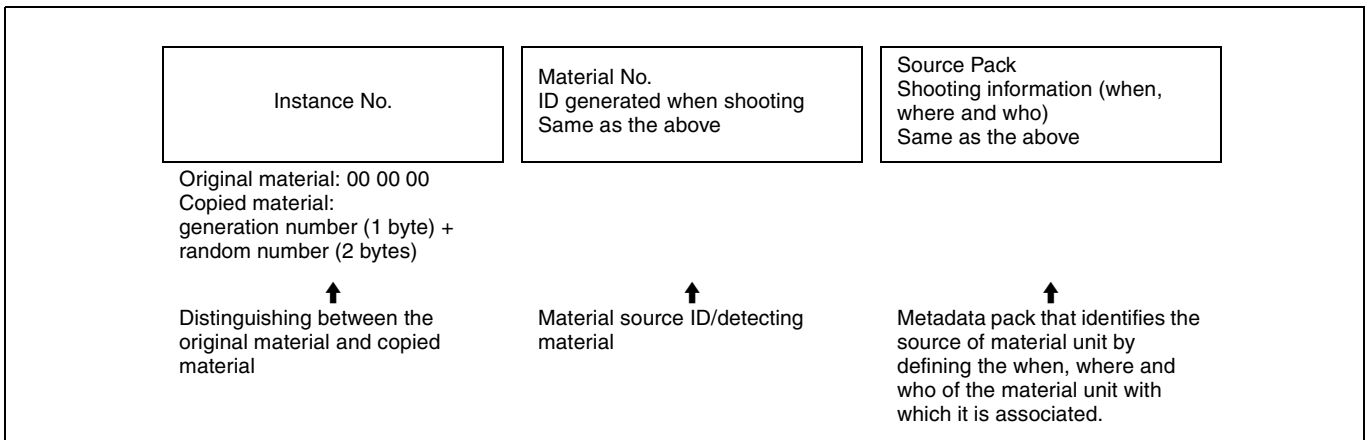

Using the Extended UMID

You have to enter a country code, organization code and user code. Set the country code referring to the ISO-3166 table, and set the organization code and user code independently.

For details, see "UMID menu setup" on page 102.

Functions of UMID data

The UMID data enables the following:

- Add a globally unique ID to every shot of audio-visual material. The unique ID is used to detect the material source and to link it with the original source material.
- Distinguishing between original material and copied material. 00 is added to the Instance Number for original material.

- Recording based on the UTC. The UTC is used when recording the UMID. This enables uniform control of source material recorded all over the world based on the universal time code.
- Calculating the date difference among source materials. The source material is recorded based on the MJD (Modified Julian Date), which enables easy calculation of date difference among source materials.

UMID menu setup

The UMID SET page of the OPERATION menu allows you to make settings for UMID data.

Proceed as follows:

- 1 Holding down the MENU knob, set the MENU ON/OFF switch from OFF to ON.

The TOP menu appears.

- 2 Turn the MENU knob to move the \blacktriangleright mark to “OPERATION,” and press the MENU knob.

If this is the first time the Operation menu has been displayed, the CONTENTS page appears.

If the menu has been used before, the last accessed page appears.

- 3 If the CONTENTS page is displayed, turn the MENU knob to move the \blacktriangleright mark to “UMID SET,” and press the MENU knob.

If a different page is displayed, turn the MENU knob until the UMID SET page appears, then press the MENU knob.

The current settings appear on the right side of each item.

UMID SET page

?210UMID SET	
EX-OWNERSHIP REC:	OFF
COUNTRY CODE	: 000 ◀
ORGANIZATION	: 00000
USER CODE	: 00000
INSTANCE NO	: RND
TIME ZONE	: 00 : +00:00
MACHINE	: 00000000000000

Proceed as follows:

Item	Contents
EX-OWNERSHIP REC	Specifies whether to record the user data.
COUNTRY CODE	Sets the country code.
ORGANIZATION	Sets the organization code.
USER CODE	Sets the user code.
INSTANCE NO.	Specifies how to generate the instance number.

Item	Contents
TIME ZONE	Sets the time difference from UTC.
MACHINE	Displays the machine-specific number.

- 4 Turn the MENU knob to move the \blacktriangleright mark to the item you want to set, and press the MENU knob.

The \blacktriangleright mark to the left of the selected item changes to a \bullet mark, and the \bullet mark to the left of the setting changes to a ? mark.

- 5 Turn the MENU knob to change the setting of the selected item or to display the desired value, and press the MENU knob.

The \bullet mark returns to a \blacktriangleright mark, and the ? mark returns to a \bullet mark.

- 6 To end the menu operation, set the MENU ON/OFF switch to OFF.

Additional information on the UMID SET menu items

EX-OWNERSHIP REC

Specify whether to record the user data.

ON: The user data (COUNTRY CODE, ORGANIZATION, and USER CODE) are recorded on the tape.

OFF: The user data are not recorded.

COUNTRY CODE

When you select this item, the character table appears.

21 UMID SET	TOP
EX-OWNERSHIP REC:	OFF
\bullet COUNTRY CODE	: 000 ◀
ORGANIZATION	: 00000
USER CODE	: 00000
INSTANCE NO	: RND
-0123456789ABCDEFGHIJKL	
MNOPQRSTUVWXYZabcdefghij	
klmnopqrstuvwxyz~	
INS DEL RET	ESC END

Enter an abbreviated alphanumeric string (4-byte alphanumeric strings) according to the values defined in ISO 3166-1.

There are about 240 country codes.

Find your own country code on the following home page.

Refer to ISO-3166-1:

http://www.din.de/gremien/nas/nabd/iso3166ma/codlstp1/en_listp1.html

When the country code is less than 4 bytes, the active part of the code will occupy the first part of the 4-bytes and the remainder must be filled with the space character (20h).

Example: In the case of Japan

For Japan, if the country code is JP, it is 2 bytes, if JPN, it is 3 bytes.

Thus, enter the following:

JP _ _

or

JPN _

where _ represents a space.

ORGANIZATION (organization code)

When you select this item, the character table appears. (Refer to COUNTRY CODE above.)

Enter an abbreviated 4-byte alphanumeric string for the organization code.

Note

There are no problems in recording or playing back audio-video signals, if ORGANIZATION is not set.

Organization codes must be acquired by applying to the SMPTE registration office. When no organization code has been acquired, it is forbidden to enter an arbitrary string.

As a rule, the code "00" must be entered. Freelance operators who do not belong to an origination should enter "~."

USER CODE

When you select this item, the USER CODE window appears.

(Refer to the COUNTRY CODE window above.)

Enter the 4-byte alphanumeric strings for user identification.

The user code is registered with each organization locally. It is usually not centrally registered.

When the user code is less than 4 bytes, enter the user code from the beginning of the 4 bytes and enter the space character (20h) in the remaining strings.

This user code is determined by the organization. The methods used depend on the organization.

Note

User bits cannot be entered when no organization code has been entered.

INSTANCE NO.

Select the method for generating the numbers to be used to identify the original video images.

RND: Random

GEN: Generation (number of times of copy)

Ask the system administrator for selection.

TIME ZONE

When you select this item, the TIME ZONE window appears.

The UTC is calculated based on the local time, using the time zone. If the time zone is not set, the UTC is not recorded correctly.

TIME ZONE	ESC
00. UTC	GREENWICH
01. UTC-01:00	AZORES
02. UTC-02:00	M-ATLANTIC
03. UTC-03:00	ARGENTINE
04. UTC-04:00	HALIFAX
05. UTC-05:00	NEW YORK
06. UTC-06:00	CHICAGO
07. UTC-07:00	DENVER
→08. UTC-08:00	LOSANGELES
09. UTC-09:00	ALASKA

Set the time difference from UTC. When setting the summer time or daylight savings time, change the code to one which will advance the time by 1 hour.

Note

When you change the time zone, adjust the built-in clock to local time and turn the power of the camcorder off and then the power on again.

MACHINE

An identification number specific to the machine is displayed. This number cannot be set or modified by users.

5-4 Resetting USER Menu Settings to the Standard Settings

You can return all settings in the USER menu to the standard settings.

Proceed as follows:

- 1 Set the MENU ON/OFF switch to ON.

The last accessed menu appears on the screen.

- 2 Turn the MENU knob until the USER FILE page appears, and press the MENU knob.

USER FILE page

```
F01USER FILE
➔USER FILE LOAD :D EXEC
USER FILE SAVE : EXEC
F.ID : □□□□□□□□□□□□□□□□
USER PRESET : EXEC
```

- 3 Turn the MENU knob to move the ➔ mark to “USER PRESET,” and press the MENU knob.

The message “PRESET OK? YES ➔ NO” appears.

```
F01USER FILE
PRESET OK? YES ➔NO
USER FILE LOAD : EXEC
USER FILE SAVE : EXEC
F.ID : □□□□□□□□□□□□□□□□
➔USER PRESET :D EXEC
```

- 4 Turn the MENU knob to move the ➔ mark to “YES,” and press the MENU knob.

The settings for all items in the USER menu are reset to the standard settings.

6-1 Saving and Loading User Files

The camcorder is equipped with a “Memory Stick” drive, which enables you to save user files, scene files, lens files, reference files and “ALL” files. You can load these files from the “Memory Stick” for immediate recall of a particular setting configuration.

When a menu page is displayed, you can set up the camcorder so that inserting a “Memory Stick” automatically jumps to the appropriate file-related menu page.

For details about scene files, see “6-2 Saving and Loading Scene Files” on page 109.

For details of the function for jumping to the appropriate file-related menu page, see “6-3 Jumping to a File-Related Menu Page When Inserting a “Memory Stick”” on page 113.

“Memory Sticks” usable with this camcorder

With this camcorder, you can use “Memory Sticks” whose capacity does not exceed 128 MB.

For details, see “Memory Stick” in “Specifications” on page 138.

6-1-1 Handling the “Memory Stick”

The “Memory Stick” can be inserted to or removed from the camcorder with the power turned on or off.

Inserting the “Memory Stick”

Proceed as follows:

- 1 Push the MEMORY STICK OPEN button.
The cover of the “Memory Stick” compartment opens.

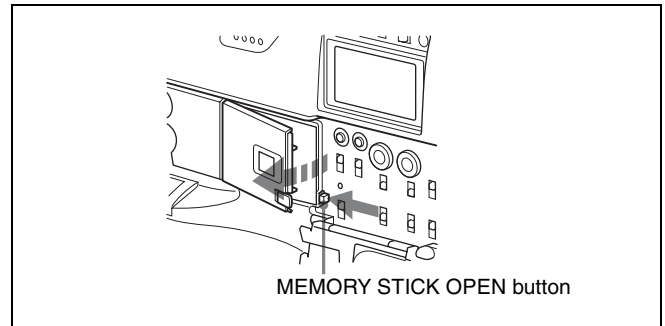

- 2 Hold the “Memory Stick” with the notch facing downward and the label side facing toward you, and insert the “Memory Stick” into the “Memory Stick” insertion slot until it clicks into place. Then, close the cover.

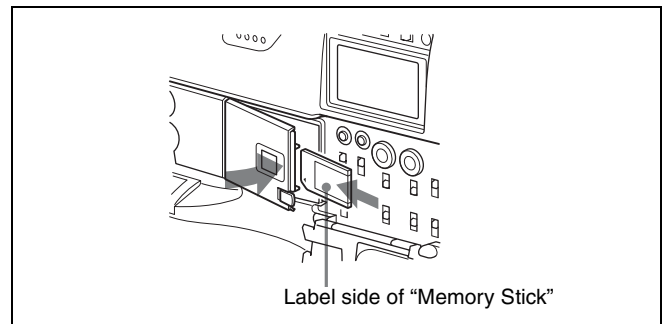

Note

If it does not fit into the slot properly or if there is some resistance when you insert it, the “Memory Stick” may be turned around or upside down. Do not force the “Memory Stick” into the slot. Confirm the direction of the notch and arrow on the “Memory Stick” before inserting the “Memory Stick,” and then try inserting it again.

Removing the “Memory Stick”

Press the MEMORY STICK OPEN button to open the cover of the “Memory Stick” compartment. Push the eject button after confirming that the ACCESS indicator is not lit. The “Memory Stick” pops out.

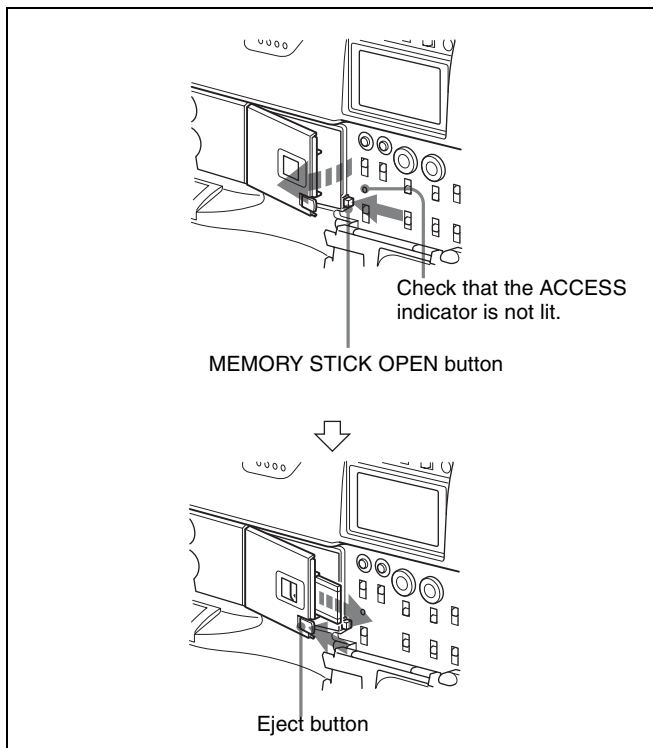

Note

Do not remove the “Memory Stick” while the ACCESS indicator is lit. You may lose data, or damage the “Memory Stick.”

Protecting saved data

To prevent accidental erasure of important setup data, use the LOCK switch on the “Memory Stick.” Slide the switch right to the write protect position. The message “MEMORY STICK LOCKED” is displayed. It is now impossible to write or delete data on the “Memory Stick.”

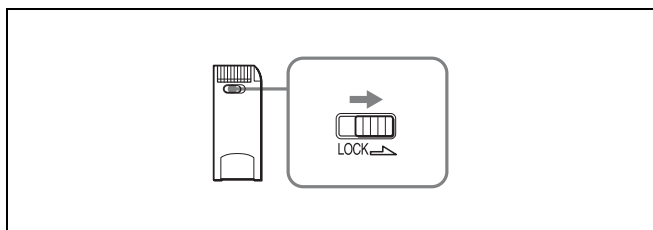

LOCK switch on the “Memory Stick”

Notes on using and storing the “Memory Stick”

- Avoid touching the connector of the “Memory Stick” or contacting it with a metal object.
- When attaching a label to the “Memory Stick,” use only the label supplied for the “Memory Stick.”
- Do not drop, bend, or submit the “Memory Stick” to external shock.
- Do not disassemble or modify the “Memory Stick.”

- Avoid getting liquids on the “Memory Stick.”
- Avoid using or storing the “Memory Stick” in a location subject to:
 - extremely high temperature such as the hot inside of a car or the outdoors exposed to a burning sun, or a place near a heater
 - direct sunlight
 - high humidity
 - excessive dust
- When storing and carrying the “Memory Stick,” keep it in its original case to ensure protection of important data.
- When carrying the camcorder with the “Memory Stick” inserted, close the cover of the menu operating section.
- Avoid removing the “Memory Stick” from the insertion slot while the access indicator is lit.
- Do not format the “Memory Stick” using a PC.
- Formatting of “Memory Sticks” can be performed on the MEMORY STICK page of the FILE menu.

6-1-2 Saving USER Menu Data (User File) to the “Memory Stick”

You can save USER menu settings held in the camcorder as user files in the “Memory Stick.”

You can save up to 100 user files in the “Memory Stick.” Insert the “Memory Stick,” then proceed as follows:

- 1 Set the MENU ON/OFF switch to ON.

The last accessed menu page appears on the viewfinder screen.
- 2 Turn the MENU knob until the USER FILE page appears, then press the MENU knob to select the page. Alternately, select “USER FILE” on the CONTENTS page.

USER FILE page

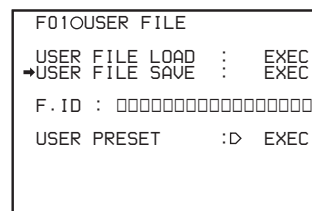

If you want to set a file ID for the data to be saved
Set the file ID before going to step 3.

For details on setting the file ID, see “Setting the file ID” on page 107.

- 3 Turn the MENU knob to move the ► mark to USER FILE SAVE, and press the MENU knob.

The P00 USER SAVE page appears.

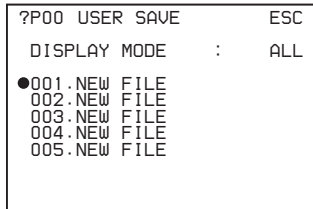

When a ? appears on the left of “P00” at the top left of the page, you can change the page. Up to 20 pages, from P00 to P19, can be used to save user files in the “Memory Stick.” Each page can hold up to 5 files.

- Turn the MENU knob until the page which contains the desired file number appears, and press the MENU knob.

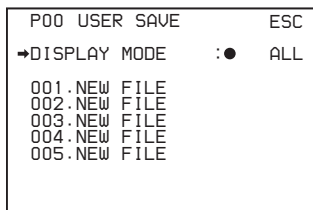

- Turn the MENU knob to move the ➡ mark to the desired file number, and press the MENU knob.

The message “SAVE OK? YES ➡ NO” appears.

When a file number is shown as “NEW FILE,” this means that the file is empty. When data is stored in a file number, the file name appears.

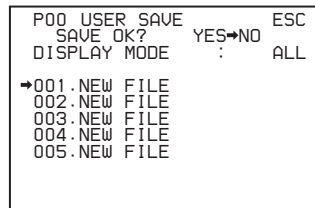

- To carry out the save, move the ➡ mark to “YES” and press the MENU knob. To cancel, press the MENU knob leaving the ➡ mark pointing to “NO.”

The ACCESS indicator lights.

When the saving is completed, the message “COMPLETE” appears and the ACCESS indicator goes off.

If no “Memory Stick” has been inserted, the message “NO MEMORY STICK” will appear. Insert a “Memory Stick.”

If you select a file number where data has already been saved

The message “OVERWRITE OK? YES ➡ NO” appears. In this case, the ➡ mark appears on the left of “NO,” which is flashing.

- To stop overwriting, press the MENU knob.

- To overwrite, move the ➡ mark to “YES” and press the MENU knob.

You can select the information displayed on each USER SAVE or USER LOAD page by changing the DISPLAY MODE setting.

For details, see “Selecting the display contents” on page 108.

- To end the menu operation, set the MENU ON/OFF switch to OFF or close the cover of the menu operating section.

The menu disappears from the viewfinder screen, and the display indicating the current status of the camcorder appears along the top and bottom of the screen.

USER menu settings to be saved in the “Memory Stick”

Settings for items on all pages of the USER menu are saved in the “Memory Stick” as a user file. However, you can select the items which are not to be saved in the “Memory Stick.”

Use the items LOAD CUSTOM DATA, LOAD OUT OF USER, BEFORE FILE PAGE and USER LOAD WHITE on the USER FILE2 page of the FILE menu.

If data cannot be saved

If one of the following error messages appears during or after the save operation, then the data was not saved.

Data save error messages

Error message	Cause	Action
NO MEMORY STICK (flashing)	No “Memory Stick” is inserted.	Insert or reinsert the “Memory Stick.”
MEMORY STICK LOCKED	The LOCK switch on the “Memory Stick” is set to the write protect position.	Set the LOCK switch to the write enable position.
MEMORY STICK ERROR (flashing)	Circuit or “Memory Stick” fault.	Check the circuitry, or replace the “Memory Stick”.

Setting the file ID

Before data is saved to a “Memory Stick,” it is useful to set a file ID for the “Memory Stick” to identify it. When data is saved to a “Memory Stick,” the file ID is saved to the “Memory Stick” together with the data.

Note

Set the file ID before saving data in the “Memory Stick.” Otherwise, the file ID is not saved with the other data.

Proceed as follows:

- 1 On the USER FILE page, turn the MENU knob to move the **▶** mark to “F. ID.”

```

F010USER FILE      TOP
USER FILE LOAD   : EXEC
USER FILE SAVE   : EXEC
▶F. ID : ████████████████████████
USER PRESET      : EXEC
  
```

- 2 Press the MENU knob.

A character table appears, allowing you to select characters you want to enter.

```

F010USER FILE      TOP
USER FILE LOAD   : EXEC
USER FILE SAVE   : EXEC
●F. ID : ?■      ◀
!#$%&'()*+,-./012345678
9:;<=>?@ABCDEFGHIJKLMNPO
QRSTUVWXYZ[^\]abcdefghijklmnop
lmnopqrstuvwxyz~
INS DEL RET      ESC END
  
```

- 3 Follow the procedure of steps 4 and 5 described in “5-2-7 Setting the Shot ID” (page 88) to enter the file ID.

- 4 When you finish entering the file ID, turn the MENU knob to move the **■** mark to “END,” then press the MENU knob.

The entered file ID is now displayed.

```

F010USER FILE      TOP
USER FILE LOAD   : EXEC
USER FILE SAVE   : D
F. ID : ████████████████████████
USER PRESET      : EXEC
  
```

File ID set in step 3

After setting the file ID, carry out the procedure from step 3 in “6-1-2 Saving USER Menu Data (User File) to the “Memory Stick”” (page 106).

The set file ID is saved in the “Memory Stick” with the data.

Selecting the display contents

You can select the contents of the file to be displayed on the USER SAVE page and USER LOAD page.

Proceed as follows:

- 1 Turn the MENU knob to move the **▶** mark to “DISPLAY MODE,” and press the MENU knob.

- 2 Turn the MENU knob to move the **▶** mark until the desired type of the display contents (see the following table) appears, then press the MENU knob.

```

P00 USER LOAD      ESC
▶DISPLAY MODE      : ● F. ID
001. USER1
002. USER2
003. NO FILE
004. USER4
005. USER5
  
```

Display type	Description
ALL	File ID (10 characters) and date ((month/day/year) for the MSW-970 and (day/month/year) for the MSW-970P))
F.ID	File ID (16 characters)
DATE	Saved date (year/month/day/hours/minutes/seconds)
MODEL	Information on the model

6-1-3 Loading Saved Data from a “Memory Stick”

Note

The data loaded from the “Memory Stick” overwrites the data saved in the camcorder.

Proceed as follows:

- 1 Set the MENU ON/OFF switch to ON.
The last accessed menu page appears on the screen.
- 2 Turn the MENU knob until the USER FILE page appears, then press the MENU knob. Alternatively, select “USER FILE” on the CONTENTS page.
- 3 Turn the MENU knob to move the **▶** mark to “USER FILE LOAD,” and press the MENU knob.

The P00 USER LOAD page appears.

```

?P00 USER LOAD      ESC
DISPLAY MODE        : ALL
001. USER1         JAN/01/04
002. USER2         JAN/15/04
003. NO FILE
004. USER4         FEB/05/04
005. USER5         FEB/20/04
  
```

- 4 Turn the MENU knob until the page which contains the desired file number appears, then press the MENU knob.

```

P00 USER LOAD      ESC
➔DISPLAY MODE      :    ALL
001 . USER1       JAN/01/04
002 . USER2       JAN/15/04
003 . NO FILE
004 . USER4       FEB/05/04
005 . USER5       FEB/20/04

```

- Turn the MENU knob to move the ➔ mark to the desired file number to be loaded, and press the MENU knob.

The message “LOAD OK? YES ➔ NO” appears.

```

P00 USER LOAD      YES➔NO  ESC
LOAD OK?          :    ALL
DISPLAY MODE      :    ALL
001 . USER1       JAN/01/04
➔002 . USER2       JAN/15/04
003 . NO FILE
004 . USER4       FEB/05/04
005 . USER5       FEB/20/04

```

- To carry out the load, move the ➔ mark to “YES” and press the MENU knob. To cancel, press the MENU knob leaving the ➔ mark pointing to “NO.”

The ACCESS indicator lights. When the load is completed, the message “COMPLETE” appears and the ACCESS indicator goes off. The USER FILE page appears again.

- To end the menu operation, set the MENU ON/OFF switch to OFF or close the cover of the menu operating section.

If data cannot be loaded

If one of the following error messages appears during or after the load operation, then the data was not loaded.

Data load error messages

Error message	Cause	Action
NO MEMORY STICK (flashing)	No “Memory Stick” is inserted.	Insert or reinsert the “Memory Stick.”
MEMORY STICK ERROR (flashing)	Circuit or “Memory Stick” fault.	Recheck, and consult your Sony representative.
OTHER MODEL'S FILE (flashing)	The “Memory Stick” contains data that cannot be loaded into this camcorder.	Do not try to load data saved from another camcorder.

6-2 Saving and Loading Scene Files

You can save various settings for shooting a particular scene as a scene file. Loading the scene file, you can quickly recreate setup conditions suitable for the scene. You can save up to five scene files in the camcorder memory and up to 100 scene files in a “Memory Stick.” You can also load data from the “Memory Stick” into the camcorder memory.

Data that can be saved in a scene file

You can save the following data in a scene file:

- Values adjusted using the PAINT menu (except the items that return to the default values when power is on, such as TEST OUT SELECT)
- Shutter speed settings made in the standard mode and ECS mode

The white balance data can be loaded only when the SCENE WHITE DATA setting on the REFERENCE page of the FILE menu is ON.

6-2-1 Saving a Scene File

Proceed as follows to save a scene file in the camcorder memory or the “Memory Stick.”

To save a scene file in the “Memory Stick,” insert the “Memory Stick” before starting the operation.

- In the TOP menu, select the FILE menu.
- Turn the MENU knob until the SCENE FILE page appears, then press the MENU knob to select the page. Alternatively, select “SCENE FILE” on the CONTENTS page to display the SCENE FILE page.

SCENE FILE page

```

F040SCENE FILE      TOP
01  : STANDARD
02  : STANDARD
03  : STANDARD
04  : STANDARD
05  : STANDARD
05  : STANDARD
SCENE RECALL      : EXEC
SCENE STORE       : EXEC
F. ID:

```

If you want to set a file ID for the data to be saved
Set the file ID before going to step 3.

For details on setting the file ID, see “Setting the file ID” on page 111.

- Turn the MENU knob to move the \blacktriangleright mark to “SCENE STORE,” and press the MENU knob.

```

F040SCENE FILE      TOP
□1  :STANDARD
□2  :STANDARD
□3  :STANDARD
□4  :STANDARD
□5  :STANDARD
□STANDARD
SCENE RECALL      : EXEC
→SCENE STORE      : EXEC
F.ID:
  
```

The SCENE STORE page appears.

```

?P00 SCENE STORE    ESC
DISPLAY MODE      : ALL
MEM-01:STANDARD
MEM-02:STANDARD
MEM-03:STANDARD
MEM-04:STANDARD
MEM-05:STANDARD
  
```

- Select the desired file number.

When no “Memory Stick” has been inserted

Turn the MENU knob to move the \blacktriangleright mark to the desired file number, and press the MENU knob. When the save is completed, the SCENE FILE page appears again.

When you select a file number where data has already been saved

The message “OVERWRITE OK? YES \blacktriangleright NO” appears. In this case, the \blacktriangleright mark is placed on the left of “NO.”

- To stop overwriting, press the MENU knob.
- To overwrite, move the \blacktriangleright mark to “YES” and press the MENU knob.

When a “Memory Stick” has been inserted

You can use up to 20 pages, from P01 to P20, to save scene files in the “Memory Stick.” Each page can hold up to 5 files.

To select a file, proceed as follows:

- Turn the MENU knob until the page which contains the desired file number appears, then press the MENU knob.

```

P01 SCENE STORE      ESC
→DISPLAY MODE      : ● ALL
001 .SCENE1         FEB/05/02
002 .STANDARD
003 .STANDARD
004 .STANDARD
005 .STANDARD
***.5FILE SAVE ← MEM1-5
  
```

- Turn the MENU knob to move the \blacktriangleright mark to the desired file number, and press the MENU knob. The message “STORE OK? YES \blacktriangleright NO” appears.

```

P01 SCENE STORE      ESC
STORE OK?          YES→NO
DISPLAY MODE       : ALL
001 .SCENE1         FEB/05/02
002 .STANDARD
003 .STANDARD
→004 .STANDARD
005 .STANDARD
***.5FILE SAVE ← MEM1-5
  
```

- To carry out the storing, move the \blacktriangleright mark to “YES” and press the MENU knob. To cancel, press the MENU knob leaving the \blacktriangleright mark pointing to “NO.”

You can select the contents of the user file to be displayed on the page.

For details, see “Selecting the display contents” on page 111.

- To end the menu operation, set the MENU ON/OFF switch to OFF or close the cover of the menu operating section.

To return to the SCENE FILE page

After the message “COMPLETE” is displayed, move the \blacktriangleright mark to “ESC” at the top right of the page by turning the MENU knob, then press the MENU knob.

White balance setting data to be saved in the scene file

The white balance setting data selected when you save the scene file is saved. For example, when the WHITE BAL switch is set to A, the adjusted values in memory A are saved in the scene file, and when the WHITE BAL switch is set to PRST, the preset value is saved.

Saving scene files from the camcorder memory to the “Memory Stick”

You can save five scene files from the camcorder to the “Memory Stick” in a single operation.

Proceed as follows:

- After displaying the SCENE FILE page (page 109) turn the MENU knob to move the \blacktriangleright mark to “SCENE STORE,” then press the MENU knob.

One of the SCENE STORE pages appears.

- Turn the MENU knob until the desired SCENE STORE page appears, then press the MENU knob.

```

P01 SCENE STORE      ESC
➔DISPLAY MODE      : ● ALL
001 . SCENE1        FEB/05/02
002 . SCENE2        FEB/06/02
003 . NO FILE
004 . SCENE4        FEB/08/02
005 . SCENE5        FEB/08/02
***.5FILE SAVE ← MEM1-5

```

- Turn the MENU knob to move the ➔ mark to “5FILE SAVE ← MEM1-5,” and press the MENU knob.

The message “SAVE OK? YES ➔ NO” appears.

```

P01 SCENE STORE      ESC
SAVE OK?           YES➔NO
DISPLAY MODE      : ALL
001 . SCENE1
002 . SCENE2
003 . NO FILE
004 . SCENE4
005 . SCENE5
➔***.5FILE SAVE ← MEM1-5

```

- To carry out the save, move the ➔ mark to “YES” and press the MENU knob.

To cancel, press the MENU knob leaving the ➔ mark pointing to “NO.”

When the save is completed, the message “COMPLETE” appears.

- To end the menu operation, set the MENU ON/OFF switch to OFF.

Note

If files have been saved in the page selected in step 2, those files are replaced with files loaded from the camcorder memory. For example, files from 001 to 005 are replaced.

Setting the file ID

Before the data is saved as a scene file, it is useful to set a file ID to identify it. The set file ID is saved together with the data.

To set the file ID, proceed as follows:

- On the SCENE FILE page, turn the MENU knob to move the ➔ mark to “F. ID.”

```

F04OSCENE FILE      TOP
01 : STANDARD
02 : STANDARD
03 : STANDARD
04 : STANDARD
05 : STANDARD
0 STANDARD
SCENE RECALL       : EXEC
SCENE STORE        : EXEC
➔F. ID:

```

- Press the MENU knob.

A character table appears, allowing you to select characters you want to enter.

```

F04OSCENE FILE      TOP
!#$%&'()*+,-./012345678
9:;<=>?@ABCDEFGHIJKLMN
OPQRSTUVWXYZ[^\]abcdefghijklmnop
lmnopqrstuvwxyz~
INS DEL RET        ESC END
0 STANDARD
SCENE RECALL       : EXEC
SCENE STORE        : EXEC
➔F. ID:

```

- Carry out the operations for steps 4 and 5 described in 5-2-7 “Setting the Shot ID” (page 88) to enter the file ID.

Note

Set the file ID before saving the scene file in the “Memory Stick” or the camcorder memory. Otherwise, the file ID is not saved with the other data.

- When you finish entering the file ID, turn the MENU knob to move the ■ mark to “END,” then press the MENU knob.

The SCENE FILE page appears again.

```

F04OSCENE FILE      TOP
01 : STANDARD
02 : STANDARD
03 : STANDARD
04 : STANDARD
05 : STANDARD
0 STANDARD
SCENE RECALL       : EXEC
SCENE STORE        : EXEC
➔F. ID: SCENE21

```

Carry out the procedure from step 3 in 6-2-1 “Saving a Scene File” (page 109).

The set file ID is saved together with the data.

Selecting the display contents

You can select the items of file information to be displayed on the SCENE STORE pages (P01 to P20) or the SCENE RECALL pages (P01 to P20) used for saving data to or loading data from a “Memory Stick.”

For details, see “Selecting the display contents” on page 108.

6-2-2 Loading a Scene File

Proceed as follows:

- In the TOP menu, select the FILE menu.
- Turn the MENU knob until the SCENE FILE page appears, then press the MENU knob to select the page. Alternatively, on the CONTENTS page select “SCENE FILE,” and press the MENU knob to display the SCENE FILE page.

3 Load a scene file.

To load a scene file stored in the camcorder

Turn the MENU knob to move the \blacktriangleright mark to the desired file number, and press the MENU knob. The \square which is displayed on the left of the file number changes to \blacksquare .

The camcorder is set up according to the loaded scene file.

```

F040SCENE FILE      TOP
□1  :SCENE 25
 $\blacktriangleright$ 2 :SCENE 26
□3  :SCENE 27
□4  :SCENE 28
□5  :NO FILE
□STANDARD

SCENE RECALL      : EXEC
SCENE STORE      : EXEC
F.ID: SCENE21

```

To cancel the selected scene file

Move the \blacktriangleright mark to \blacksquare , and press the MENU knob. \blacksquare changes to \square .

The camcorder returns to the settings before selecting this scene file.

To load a scene file saved in the “Memory Stick”

Proceed as follows:

- 1 Turn the MENU knob to move the \blacktriangleright mark to “SCENE RECALL,” and press the MENU knob.

The P00 SCENE RECALL page appears.

```

?P00 SCENE RECALL  ESC
DISPLAY MODE      : F.ID

MEM<1>:STANDARD
MEM<2>:STANDARD
MEM<3>:STANDARD
MEM<4>:STANDARD
MEM<5>:NO FILE

```

- 2 Turn the MENU knob until the page which contains the desired file number appears, then press the MENU knob.
- 3 Turn the MENU knob to move the \blacktriangleright mark to the desired file number, and press the MENU knob.

The message “RECALL OK? YES \blacktriangleright NO” appears.

```

P01 SCENE RECALL  ESC
RECALL OK? YES $\blacktriangleright$ NO
DISPLAY MODE      : ● ALL

001 .SCENE1
002 .SCENE2
003 .NO FILE
004 .SCENE4
005 .SCENES

***.5FILE LOAD  $\blacktriangleright$  MEM1-5

```

- 4 To carry out the recall, move the \blacktriangleright mark to “YES” and press the MENU knob.

To cancel, press the MENU knob leaving the \blacktriangleright mark pointing to “NO.”

When the loading is completed, the message “COMPLETE” appears. The camcorder is set up according to the loaded scene file.

If no file is present with a particular file number, this is shown as “NO FILE.”

- 5 To end the menu operation, set the MENU ON/OFF switch to OFF.

Loading scene files from a “Memory Stick” into the camcorder memory

You can load up to five scene files stored in the “Memory Stick” into the camcorder memory in a single operation.

- 1 After displaying the SCENE FILE page (*page 109*), turn the MENU knob to move the \blacktriangleright mark to “SCENE RECALL,” and press the MENU knob.

A SCENE RECALL page appears.

- 2 Turn the MENU knob until the SCENE RECALL page which contains the desired scene files appears, then press the MENU knob.

- 3 Turn the MENU knob to move the \blacktriangleright mark to “5FILE LOAD \blacktriangleright MEM 1-5,” and press the MENU knob.

The message “RECALL OK? YES \blacktriangleright NO” appears.

```

P01 SCENE RECALL  ESC
RECALL OK? YES $\blacktriangleright$ NO
DISPLAY MODE      : ALL

001 .SCENE1
002 .SCENE2
003 .NO FILE
004 .SCENE4
005 .SCENES

 $\blacktriangleright$ ***.5FILE LOAD  $\blacktriangleright$  MEM1-5

```

- 4 To carry out the recall, move the \blacktriangleright mark to “YES” and press the MENU knob. To cancel, press the MENU knob leaving the \blacktriangleright mark pointing to “NO.”

When loading is complete, the message “COMPLETE” appears and the ACCESS indicator goes off.

- 5 To end the menu operation, set the MENU ON/OFF switch to OFF or close the cover of the menu operating section.

Notes

- The scene files loaded from the “Memory Stick” overwrite data saved in the camcorder memory.

- To load the scene file saved in the camcorder memory when the “Memory Stick” is inserted, return to the P00 SCENE RECALL page and load the desired scene file in the camcorder memory.
- When there is no file to be loaded (shown as “NO FILE”), an existing file of the same number is unaffected. In the example shown in step 3, MEM(3) is not overwritten.

6-2-3 Resetting the Settings of the Camcorder to the Standard Settings Saved in the Reference File

You can reset the settings of the camcorder to the settings saved in the reference file (standard settings).

For details about the items in the reference file, refer to the Maintenance Manual.

On the SCENE FILE page, turn the MENU knob to move the ➔ mark to “STANDARD,” and press the MENU knob.

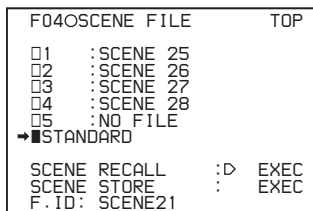

The displayed on the left of STANDARD changes to . When changes to , the settings of the camcorder are reset to the settings saved in the reference file.

If you press the MENU knob again while is displayed, the operation is cancelled and the camcorder returns to the settings before STANDARD was selected.

6-3 Jumping to a File-Related Menu Page When Inserting a “Memory Stick”

A “Memory Stick” enables you to save user files, scene files, lens files, reference files and “ALL” files. The camcorder menu system allows you to make a setting so that when a “Memory Stick” holding these files is inserted while in menu operating mode, a menu page relating to the desired file is automatically displayed on the screen. Thus you can proceed to file operation quickly. This is very convenient especially when you manage data files using “Memory Sticks.”

The page to be displayed can be selected on the MEMORY STICK page of the FILE menu.

To make this setting, proceed as follows:

- 1 In the TOP menu, select the FILE menu.
- 2 Turn the MENU knob until the MEMORY STICK page of the FILE menu appears, then press the MENU knob to select the page. Alternatively, on the CONTENTS page select MEMORY STICK.

MEMORY STICK page

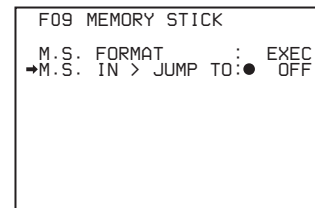

- 3 Turn the MENU knob to move the ➔ mark to “M.S. IN > JUMP TO,” and press the MENU knob.

The ➔ mark on the left of “M.S. IN > JUMP TO” changes to a ● mark, and the ● mark on the left of the setting changes to a ? mark.

- 4 Turn the MENU knob to select the desired setting (target FILE menu page).

Setting	Description
OFF	Disables this function.
USER	Jumps to the USER FILE page.
ALL	Jumps to the ALL FILE page.
SCENE	Jumps to the SCENE FILE page.
LENS	Jumps to the LENS FILE 1 page.

Setting	Description
REFER	Jumps to the REFERENCE page.
USER 1	Jumps to the USER 1 page.

5 Press the MENU knob to confirm the selection.

The ● mark returns to a ➔ mark, and the ? mark returns to a ● mark.

Notes

In the following cases, jumping to the target page is impossible.

- When the power is turned on after you insert a “Memory Stick.”
- When OFF is selected for the M.S. IN > JUMP TO item.
- When any of the following menu pages is already displayed.
 - A file-related page such as the USER FILE page of the FILE menu
 - MEMORY STICK, ALL FILE, SCENE FILE, LENS FILE, REFERENCE FILE or ROM VERSION page



7-1 Power Supply

The following power supplies can be used with the camcorder.

- BP-GL65/GL95/L60S Lithium-ion battery pack
- AC power using the AC-550/550CE or AC-DN10 AC adaptor

7-1-1 Using a Battery Pack

When a BP-GL95 battery pack is used, the camcorder will operate continuously for about 180 minutes. When a BP-GL65 is used, the camcorder will operate continuously for about 120 minutes.

Before use, charge the battery pack with a BC-M50/M150 Battery Charger. It takes about 145 minutes to charge one BP-GL95.

For details, refer to the battery charger operation manual.

Note on using the battery pack

A warm battery pack may not be able to be fully recharged.

Attaching the battery pack

- 1 Press the battery pack against the back of the camcorder, aligning the line on the side of the battery pack with the matching line on the camcorder.

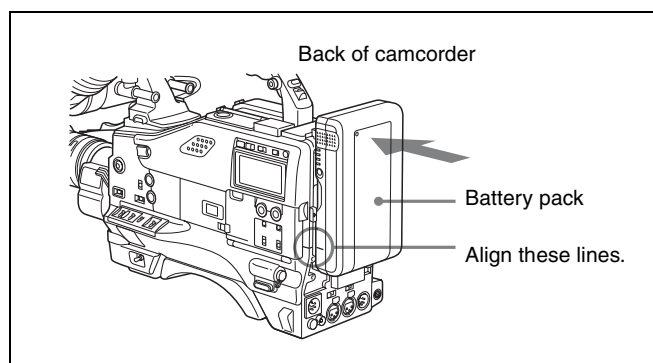

- 2 Slide the battery pack down until its "LOCK" arrow points at the matching line on the camcorder.

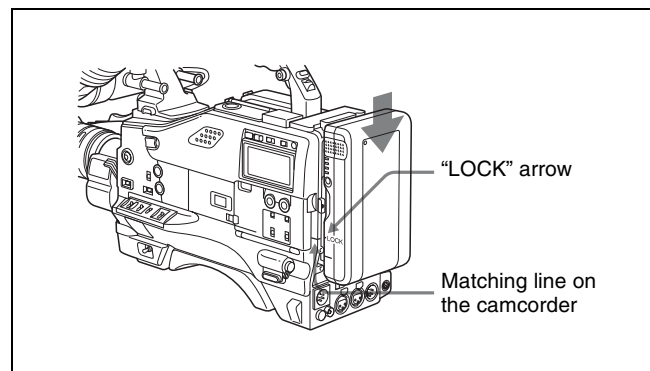

Detaching the battery pack

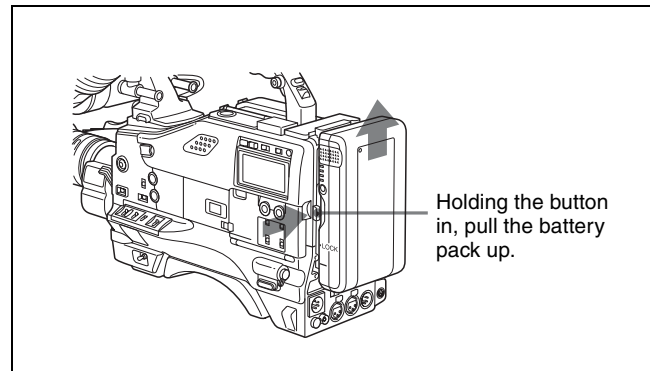

Detaching the battery pack

7-1-2 Avoiding Breaks in Operation Due to an Exhausted Battery

If you use both an internal battery pack (attached to the camcorder) and an external battery (connected to the DC IN connector) at the same time, you can avoid breaks in operation due to dead batteries.

When the external battery begins to fail and an internal battery pack is also used

Remove the DC output cable from the DC IN connector. The power source will switch to the internal battery pack.

When the external battery begins to fail and an internal battery pack is not used

First load the camcorder with a fully charged internal battery pack, then remove the DC output cable of the external battery from the DC IN connector. The power source will switch to the internal battery pack. To use an external battery again, connect a fully charged external battery to the DC IN connector before unloading the internal battery pack. The power source will switch to the external battery.

Continuous operation when operating with only an internal battery pack

First, connect a fully charged external battery to the DC IN connector, then change the internal battery.

Notes

- When an internal battery pack is loaded and an external battery is connected to the DC IN connector, the external battery is always used as the power source.
- There may be some noise on the video signal at the instant the power sources are switched.

7-1-3 Using an AC Adaptor

Using the AC-550/550CE AC adaptor

Connect the camcorder to the AC power supply through the AC-550/550CE AC Adaptor as shown in the following figure, and turn the POWER switch of the AC-550/550CE on.

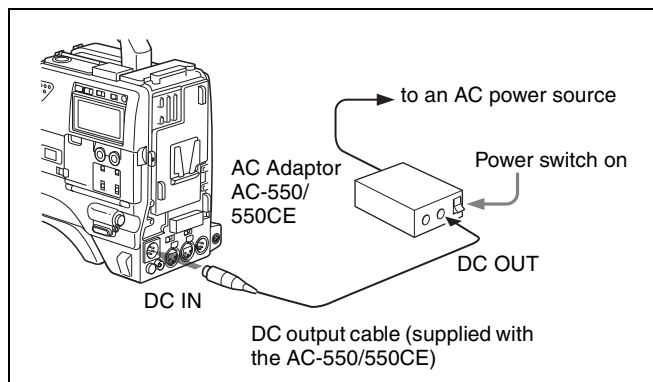

Using an AC adaptor

Using the AC-DN10 AC adaptor

Mount the AC-DN10 on the camcorder in the same way as a battery pack, then connect to the AC power supply. The AC-DN10 can supply up to 100 W of power.

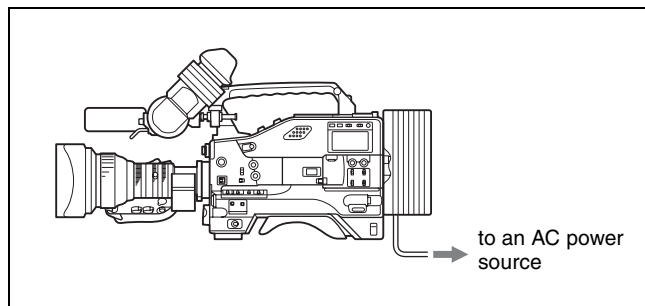

Connecting to an AC power source using the AC-DN10 AC Adaptor

7-1-4 Using the Anton Bauer Ultralight System

By fitting the camcorder with the Anton Bauer Ultralight system, and setting the LIGHT switch to AUTO, you can switch the light on and off automatically as you start and stop VTR operation. This system operates with lights powered by 12 V, with a maximum power consumption of 50 W.

7-2 Adjusting the Viewfinder

For maximum viewing convenience, you can adjust the viewfinder position in the left-right and backward-forward directions.

7-2-1 Adjusting the Viewfinder Position

Adjusting the position to the left or right

Proceed as follows:

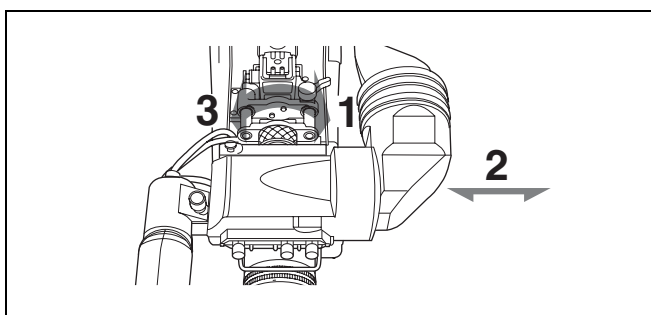

Adjusting the position to the left or right

- 1 Loosen the viewfinder left-right positioning ring.
- 2 Slide the viewfinder to the most convenient position.
- 3 Tighten the viewfinder left-right positioning ring.

To store the camcorder in the carrying case

Always store the camcorder with the viewfinder moved fully in the direction opposite to the barrel and the viewfinder left-right positioning ring tightened.

Adjusting the position backward or forward

Proceed as follows:

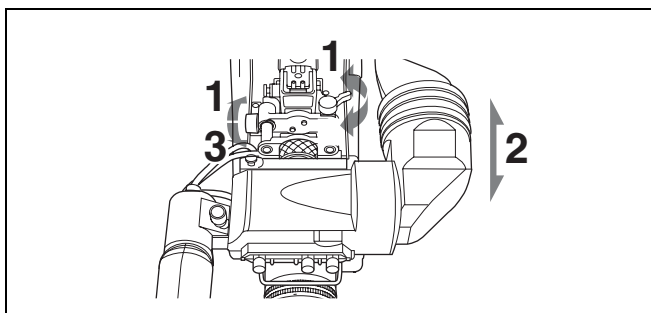

Adjusting the position backward or forward

- 1 Loosen the viewfinder front-rear positioning lever and the LOCK knob.
- 2 Slide the viewfinder longitudinally to the most convenient position.
- 3 Tighten the viewfinder front-rear positioning lever and the LOCK knob.

7-2-2 Adjusting the Viewfinder Focus and Screen

Adjusting the viewfinder focus

Turn the diopter adjustment ring until the viewfinder image is sharpest.

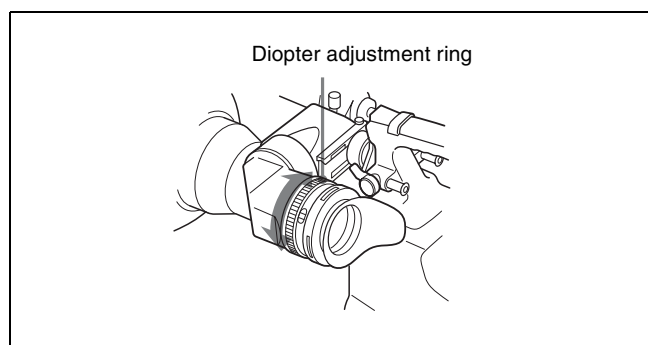

Adjusting the viewfinder focus

Adjusting the viewfinder screen

Adjust the brightness, contrast, and peaking of the viewfinder screen with the controls shown below:

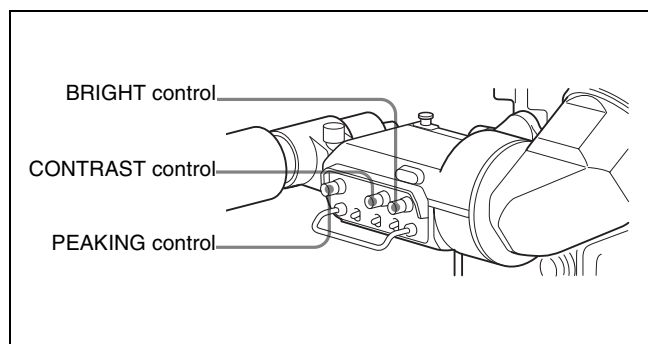

Adjusting the viewfinder screen

7-2-3 Detaching the Viewfinder

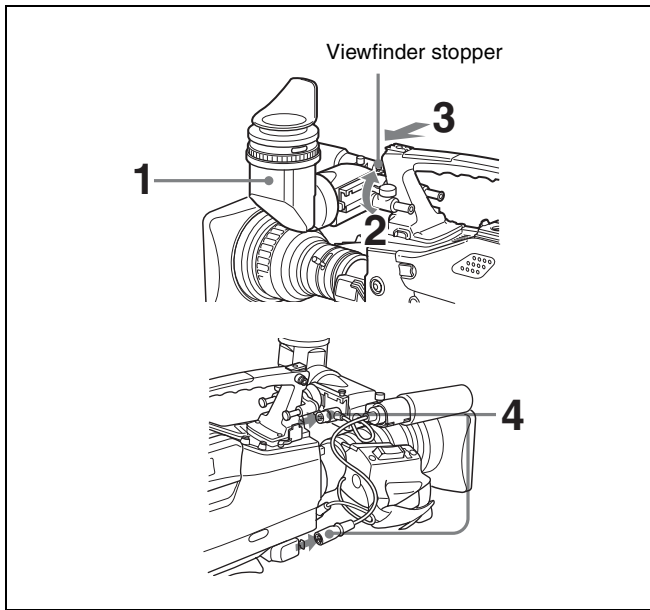

Detaching the viewfinder

- 1 Point the viewfinder barrel up or down.
- 2 Loosen the viewfinder left-right positioning ring.
- 3 Holding the viewfinder stopper up, slide the viewfinder in the direction indicated by the arrow and detach it.
- 4 Remove the viewfinder cable and microphone cable from the clamps and disconnect them.

Using the viewfinder rotation bracket

By fitting a BKW-401 Viewfinder Rotation Bracket (not supplied), you can rotate the viewfinder out of the way so that your right leg does not hit the viewfinder while you are carrying the camcorder.

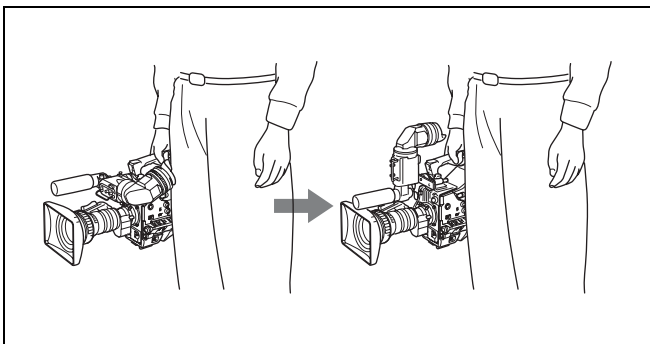

Using the BKW-401 Viewfinder Rotation Bracket

For more information, refer to the BKW-401 manual.

7-2-4 Detaching the Eyepiece

Removing the eyepiece gives a clearer view of the screen from further away. It is also easy to remove dust from the viewfinder screen and mirror when the eyepiece is detached.

- 1 Turn the eyepiece locking ring fully counterclockwise, to align the red marks on the locking ring and the viewfinder barrel.

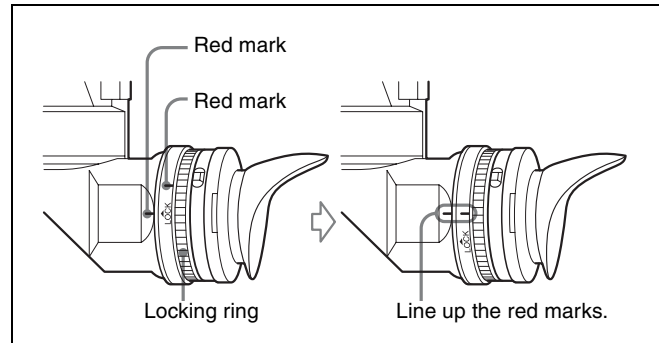

- 2 Detach the eyepiece.

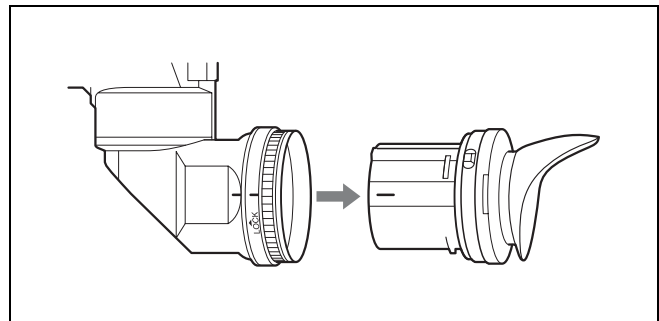

Reattaching the eyepiece

- 1 Align the red marks on the eyepiece locking ring and the viewfinder barrel.
- 2 Align the red mark on the end of the eyepiece end with the red marks on the eyepiece locking ring and the viewfinder barrel. Then insert the eyepiece into the viewfinder barrel.

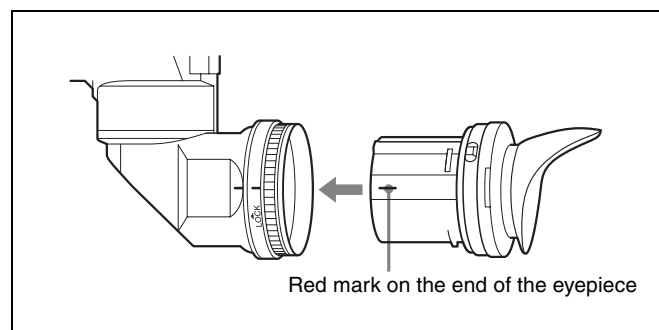

- 3 Turn the eyepiece locking ring clockwise until its “LOCK” arrow points at the red mark on the viewfinder barrel.

Note

When the eyecup is worn out, replace it with a new one (service part number 3-723-079-03).

7-3 Mounting the Lens

To mount the lens, proceed as follows:

For information about using the lens, refer to the lens manual.

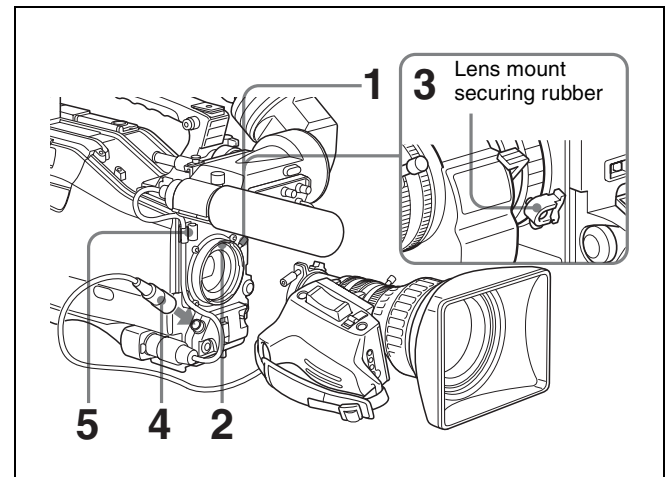

Mounting the lens

- 1 Push the lens locking lever upward and remove the lens mount cap from the lens mount.
- 2 Align the center slot in the lens mount with the center pin on the lens and insert the lens into the mount.
- 3 Holding the lens in place, push the lens locking lever downward to mount the lens.

Note

If the lens is not firmly locked, it may come off while the camcorder is being used. This could cause a serious accident. Make sure the lens is firmly locked. It is recommended that the lens mount securing rubber (supplied) be put on the lens-locking lever as illustrated above.

- 4 Connect the lens cable to the LENS connector.

Note

Connecting a cable to the LENS connector while in powered status may cause a malfunction or damage the unit. Turn off the power before you make a connection with the LENS connector.

- 5 Secure the lens cable with the cable clamps.

7-4 Adjusting the Flange Focal Length

If the lens does not stay in focus properly as you zoom from telephoto to wide angle, adjust the flange focal length (the distance from the plane of the lens mounting flange to the imaging plane). Make this adjustment after mounting or changing the lens.

Adjusting the flange focal length

The position of the controls for adjusting the flange focal length vary somewhat from lens to lens. Check the identification of the various controls in the lens manual.

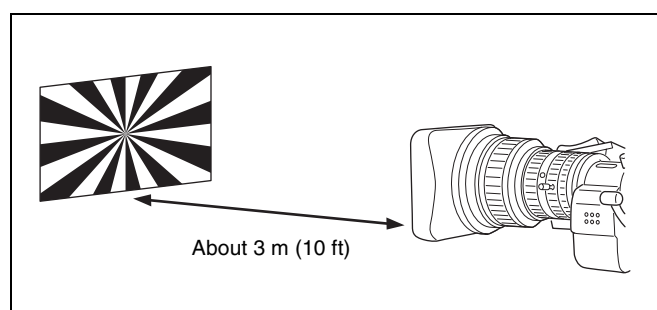

Adjusting the flange focal length

- 1 Set the iris to manual.
- 2 Open the iris. Place the flange focal length adjustment chart about 3 m (10 ft) away from the camera, lit well enough to provide a satisfactory video output level.
- 3 Loosen the fixing screws on the F.f or F.B ring (flange focal length adjustment ring).
- 4 Use manual or power zoom to set the lens to telephoto.
- 5 Point the camera at the chart by turning the focus ring and focus on it.
- 6 Set the zoom ring to wide angle.
- 7 Turn the F.f or F.B ring until the chart is in focus, being careful not to disturb the focus ring.
- 8 Repeat steps 4 to 7 until the chart stays in focus all the way from wide angle to telephoto.
- 9 Tighten the F.f or F.B ring fixing screws.

7-5 Audio Input System

7-5-1 Using the Supplied Microphone

You can use the supplied microphone either detached from or attached to the camcorder.

Using the microphone detached from the camcorder

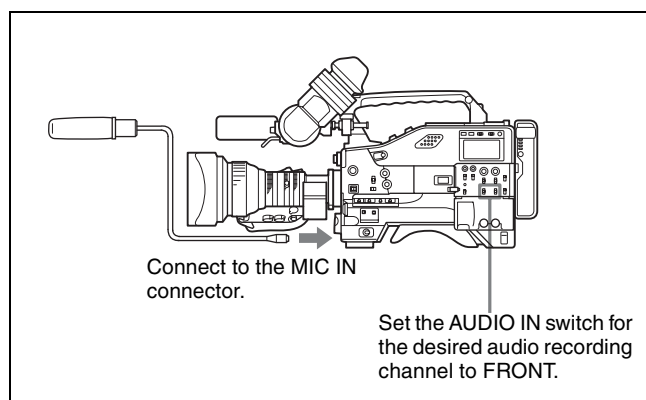

Using the supplied microphone detached from the camcorder

Note

When using the supplied microphone with an extension cable, always use an external power supply type cable.

Using the microphone attached to the camcorder

- 1 Loosen the screw and open the microphone holder clamp.

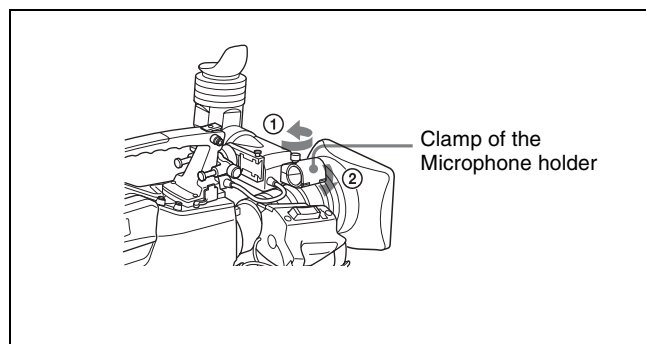

- Place the microphone in the microphone holder.

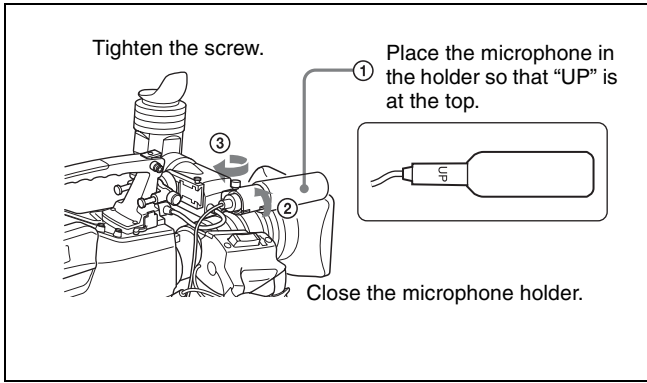

- Plug the microphone cable into the MIC IN connector, then set the AUDIO IN switch for the desired recording channel to FRONT.

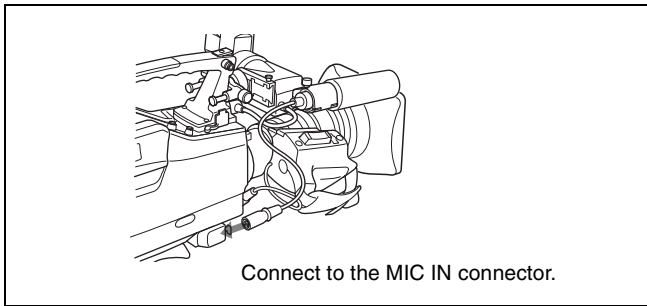

7-5-2 Using an External Microphone

You can connect up to two external microphones using the AUDIO IN CH1 and CH2 connectors.

When using a condenser microphone that requires external power (phantom power), set the LINE/MIC/+48 V ON switch to +48 V ON.

If the microphone being used does not require external power (dynamic microphone), set the LINE/MIC/+48 V ON switch to MIC.

Using a detached external microphone

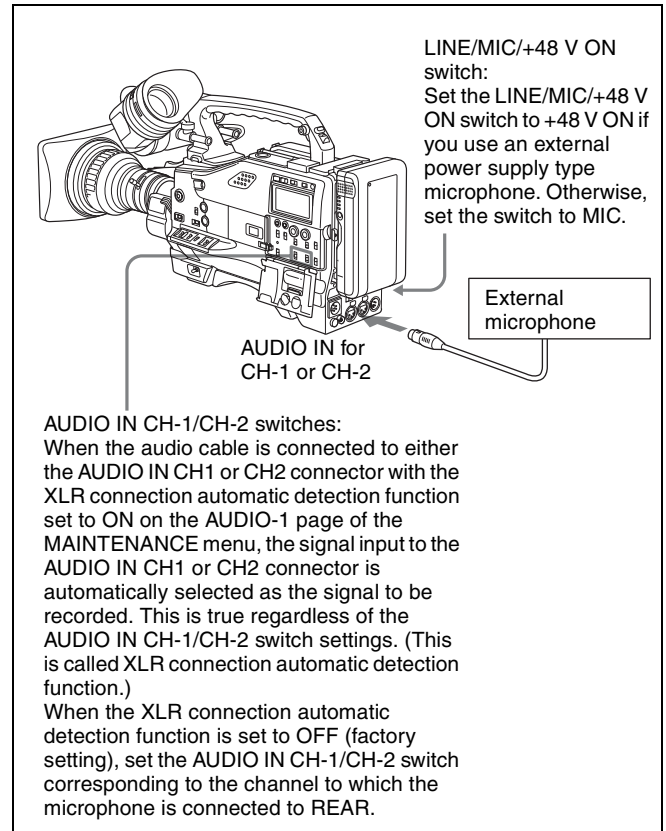

Note

In order for the AUDIO IN CH1 and CH2 connectors on the camcorder to be able to provide a phantom 48 V power supply, female XLR connectors (3-pin) are fitted. If the microphone cable has a female connector, use an adaptor.

Using an external microphone attached to the camcorder

You can attach an external microphone to the camcorder using the optional CAC-12 microphone holder.

- Remove the fixing screws for external microphone holder.

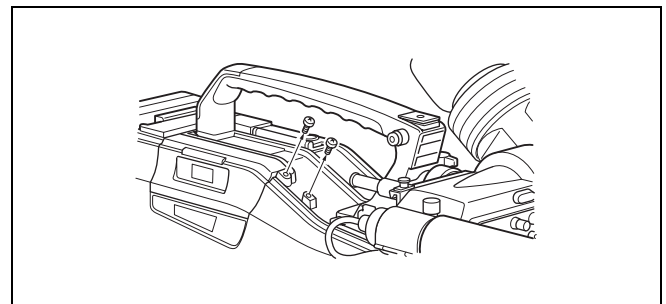

- Attach the CAC-12 Microphone Holder.

Screws removed
in step 1

CAC-12

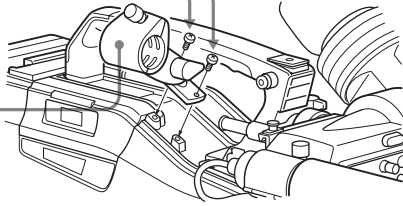

- 3** Open the CAC-12 and remove the microphone adaptor.

Open the CAC-12.

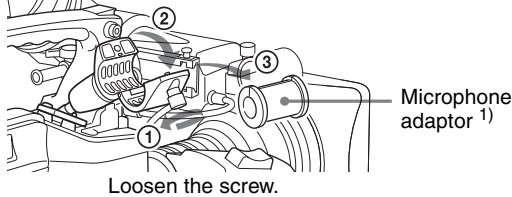

Loosen the screw.

1) Attach the microphone adaptor when using a small-diameter external microphone.

- 4** Place an ECM-672 electret condenser microphone in the CAC-12.

Close the CAC-12.

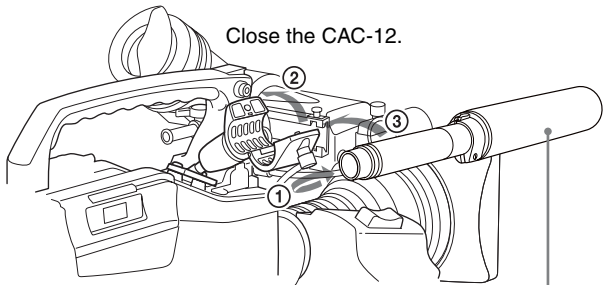

Tighten the screw.

ECM-672 or similar
microphone

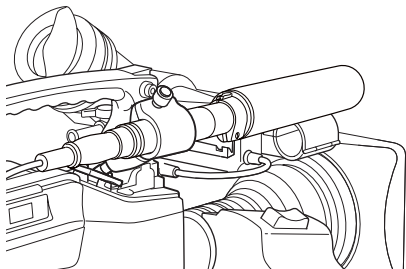

- 5** Connect the microphone cable to the AUDIO IN CH1 or AUDIO IN CH2 connector.
Set the LINE/MIC/+48 V ON switch to +48 V ON if you use an external power supply type microphone. Otherwise, set the switch to MIC.

Note

When you detach the CAC-12 Microphone Holder once you have attached to the camcorder, be careful not to lose the two screws fixing the CAC-12. After detaching the CAC-12, be sure to put the two screws back into their original places (*see the figure illustrating the step 1 operation*).

7-5-3 Attaching a UHF Portable Tuner (for a UHF Wireless Microphone System)

To use a Sony UHF wireless microphone system, fit one of the following UHF portable tuners.

- WRR-855A/855B UHF Synthesized Tuner Unit
- WRR-860/862 UHF Portable Tuner.

For each of these UHF portable tuners, use the following attachment procedure.

For details, refer to the UHF portable tuner manual.

Fitting the WRR-855A/855B

You can use the WRR-855A/855B UHF Synthesized Tuner Unit simply by inserting it into the slot in the camcorder, and fastening the fixing screws.

- 1** Undo the four fixing screws holding the cover of the

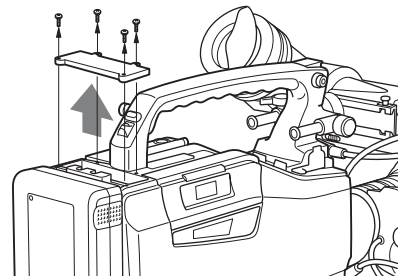

- 2** Insert the WRR-855A/855B, and fasten the four fixing screws.

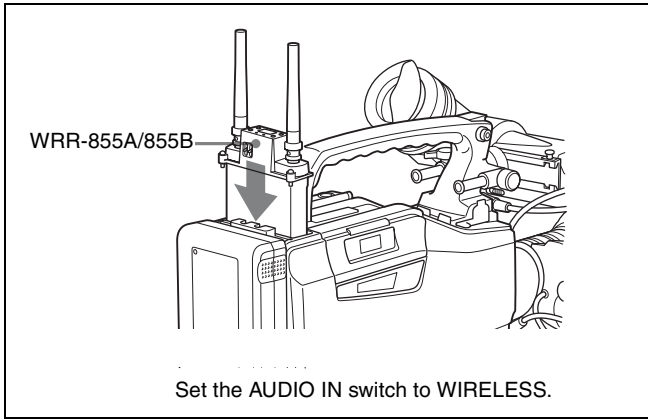

For the operation of the WRR-855A/855B, refer to the manual supplied with the WRR-855A/855B.

Notes

- When the XLR connection automatic detection function is on, even if the AUDIO IN CH-1 or CH-2 switch is set to WIRELESS, the signal input to the AUDIO IN CH1 or CH2 connector is automatically selected when an audio cable is connected to the AUDIO IN CH1 or CH2 connector. In such a case, set REAR XLR AUTO to OFF on the AUDIO-1 page of the MAINTENANCE menu.
- The audio signals to be recorded on audio channels 3 and 4 depend on the settings of the AUDIO IN CH-3/CH-4 switches without being affected by the XLR connection automatic detection function.

Fitting the WRR-862 (with a battery pack)

- 1** (1) Attach the WRR tuner fitting (not supplied, service part number: A-8278-057-A) to the back of the camcorder.

 - ① Use a Phillips-type screwdriver to tighten the four screws placed in the tuner fitting. For three of these screws, insert the screwdriver through the corresponding hole and tighten the screw.
 - ② Loosen the adjustment screws.
 - ③ Adjust the tuner fitting position for a battery pack to be attached, and tighten the adjustment screws to fix its position.
 - ④ Attach the mount plate supplied with the WRR-862.

(2) Attach the battery pack.

For details about attaching the battery pack, see “7-1-1 Using a Battery Pack” on page 115.

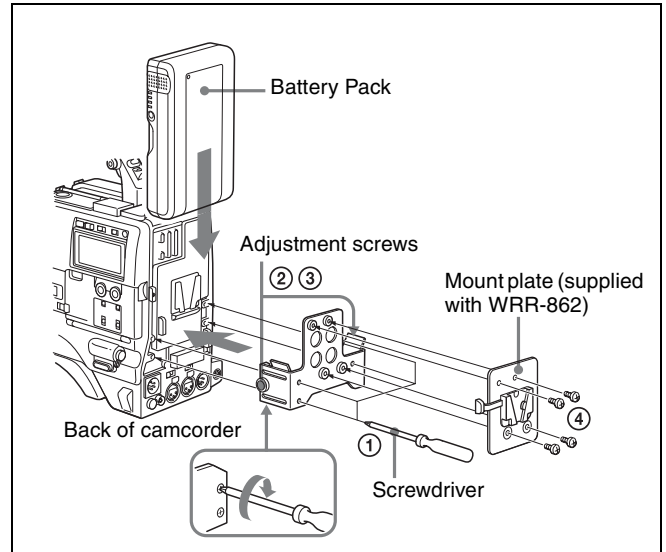

2 Mount the tuner on the WRR tuner fitting.

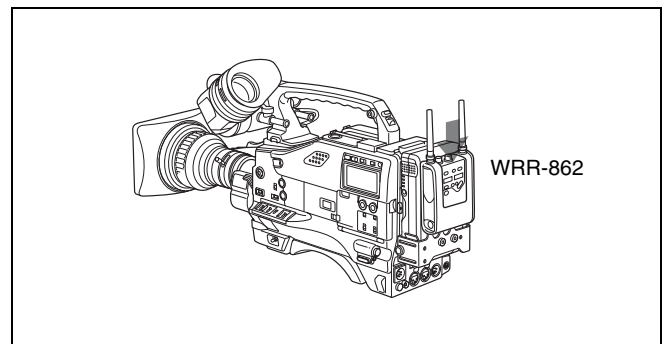

3 Connect the tuner power cord to the DC OUT connector of the camcorder, and the audio output cable to the AUDIO IN CH1 or CH2 connector.

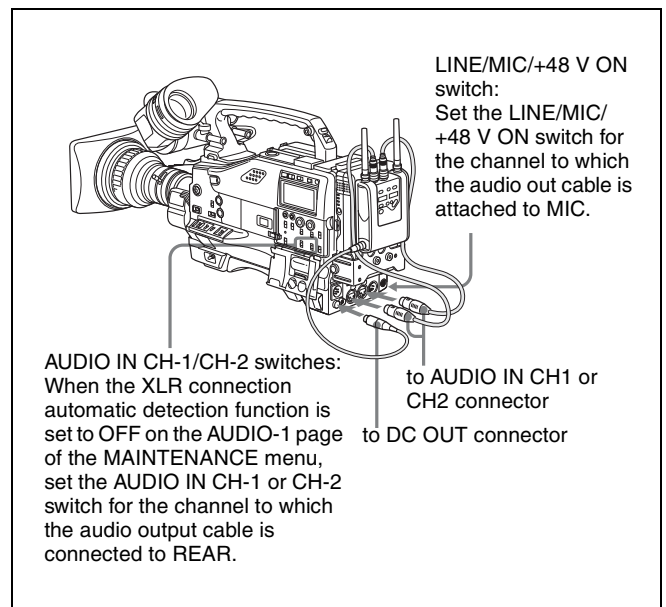

7-5-4 Connecting Line Input Audio Equipment

Connect the audio output connector of the audio equipment that supplies the line input signal to the AUDIO IN CH1 or CH2 connector.

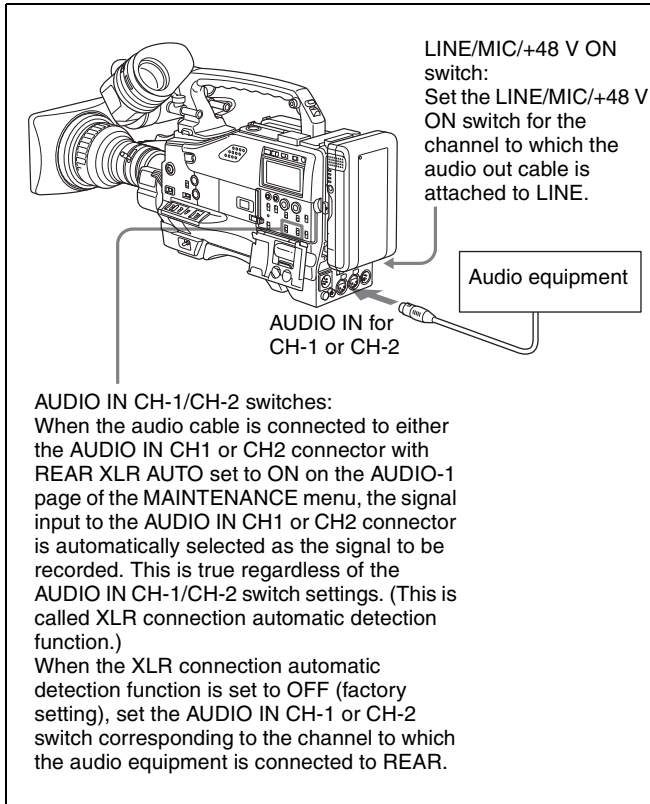

7-6 Tripod Mounting

You can easily mount and dismount the camcorder on a tripod by using the VCT-14 tripod adaptor (not supplied).

1 Attach the tripod adaptor to the tripod.

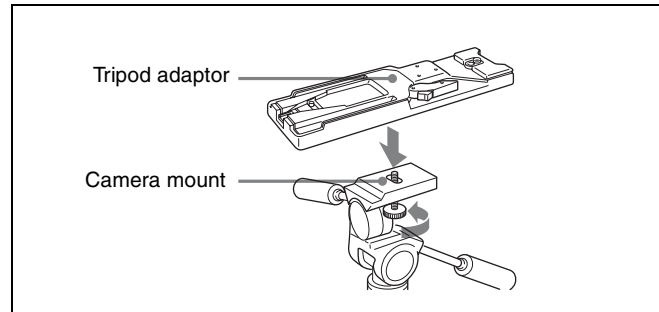

2 Mount the camcorder on the tripod adaptor.

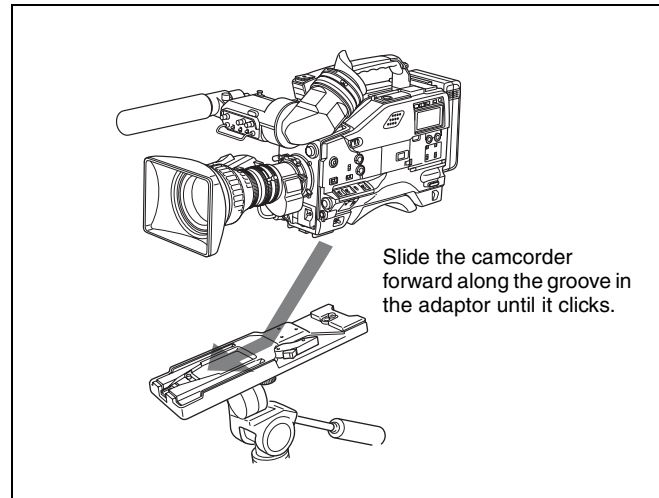

Removing the camcorder from the tripod adaptor

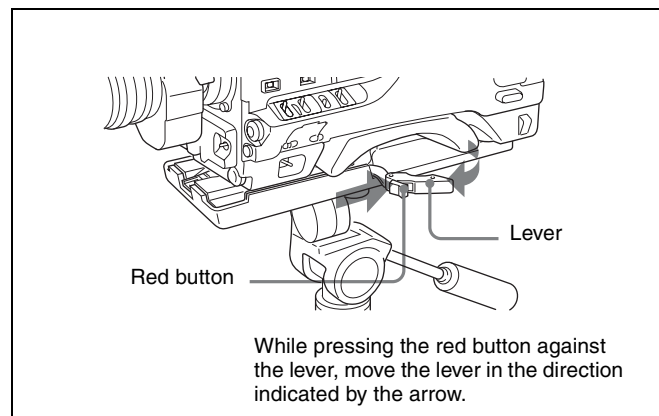

Removing the camcorder from the tripod adapter

Note

The tripod adaptor pin may remain in the engaged position even after the camcorder is removed. If this happens, press the red button against the lever a second time and move the lever as shown below until the pin returns to the stowed position. If the pin remains in the engaged position, you will not be able to mount the camcorder on the tripod adaptor.

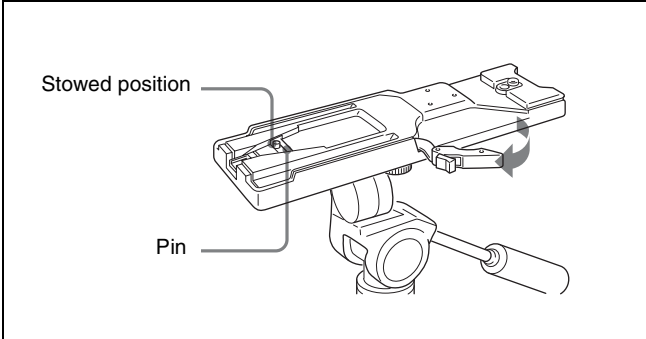

If the pin remains in the engaged position

7-7 Attaching/Detaching the Shoulder Strap

Attaching the shoulder strap

Attach the supplied shoulder strap as shown below:

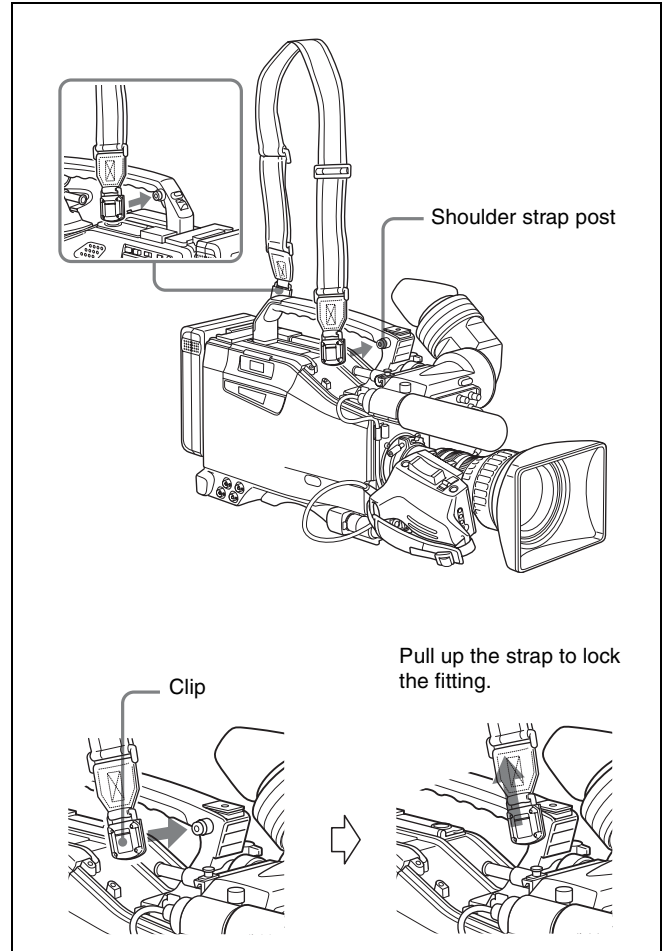

Removing the shoulder strap

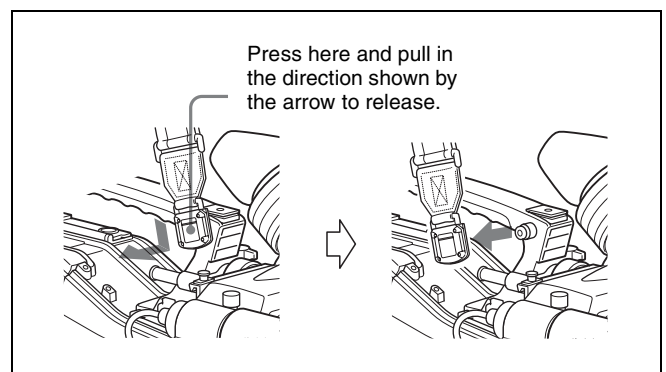

7-8 Adjusting the Shoulder Pad Position

You can shift the shoulder pad from its center position (factory setting) backward by up to 10 mm (3/8 inch) or forward by up to 25 mm (1 inch). This adjustment helps you get the best balance for shooting with the camcorder on your shoulder.

Proceed as follows:

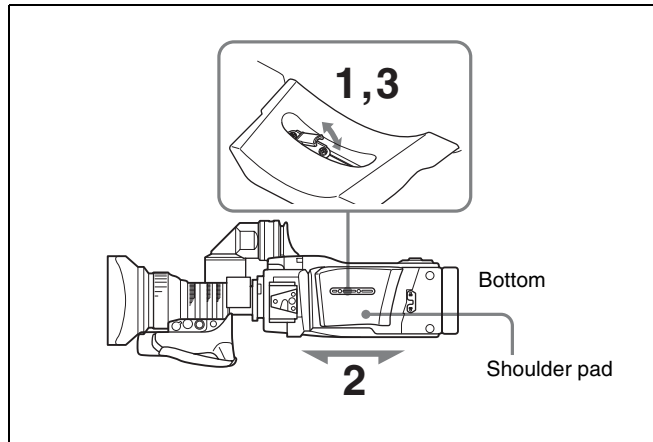

Adjusting the shoulder pad position

- 1 Raise the lever in the center of the shoulder pad to unlock the shoulder pad.
- 2 Slide the shoulder pad backward or forward until it is in the most convenient position.
- 3 Bring down the lever to lock the shoulder pad in the selected position.

7-9 Putting on the Rain Cover (Not Supplied)

Attach the rain cover (part number 3-191-064-02) as illustrated below. You can insert and remove cassette tapes, operate various switches and controls, and mount the camcorder on the tripod adaptor with the rain cover attached.

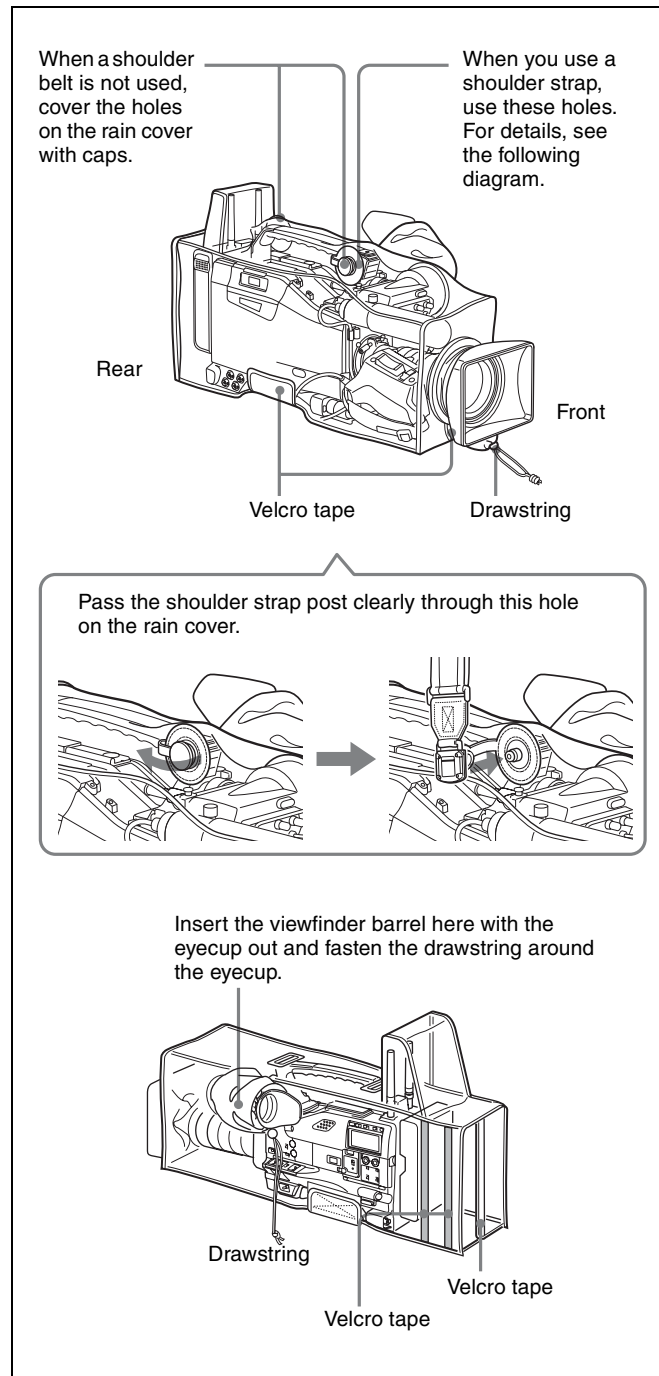

7-10 Connecting the Remote Control Unit

Connecting the RM-B150/B750 Remote Control Unit (optional) enables remote control of the principal camera functions.

Connecting the remote control unit to the REMOTE connector (8-pin) automatically puts the camcorder into remote control mode. If you disconnect the remote control unit, the remote control mode is cancelled.

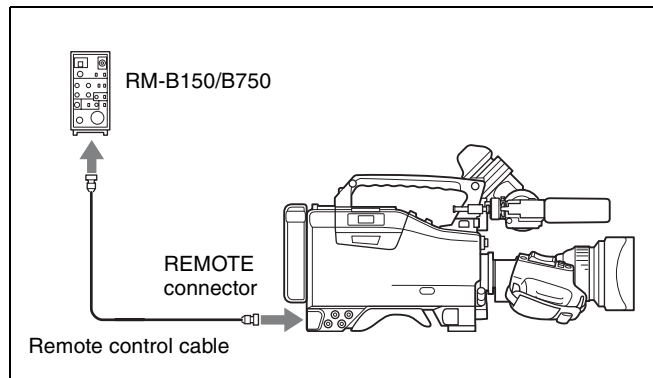

Camcorder switch functions when the remote control unit is connected

The following switches on the camcorder do not function.

- GAIN selector
- OUTPUT/DCC switch
- WHITE BAL switch
- AUTO W/B BAL switch
- SHUTTER selector
- TURBO GAIN button (ASSIGN 1 switch to which the TURBO GAIN function is assigned)
- VTR START button (VTR button on the lens and the ASSIGN 1 or the TURBO GAIN switch to which the VTR START/STOP function is assigned) (When the RM REC START item on the FUNCTION 3 page of the MAINTENANCE menu is set to RM.)

For details of the function of the VTR START button, see the item “Function of the VTR START button when the remote control unit is connected” on this page.

Paint adjustment when the remote control unit is connected

If RM COMMON MEMORY is set to OFF on the FUNCTION 3 page of the MAINTENANCE menu. The settings of the paint adjustment that were in effect the last time the remote control unit was used are recalled.

Function of the VTR START button when the remote control unit is connected

You can select the function of the VTR START button on the camcorder when the remote control unit is connected, using the RM REC START item on the FUNCTION 3 page of the MAINTENANCE menu.

To disable the camcorder VTR START button and the lens VTR button

On the FUNCTION 3 page of the MAINTENANCE menu, set RM REC START to “RM.”

If the same function as that of the VTR START button is assigned to the ASSIGN 1 switch or the TURBO GAIN button, this setting also disables these controls.

To enable the camcorder VTR START button and the lens VTR button

On the FUNCTION 3 page of the MAINTENANCE menu, set RM REC START to “CAM” or “PARA.”

If the same function as that of the VTR START button is assigned to the ASSIGN 1 switch or the TURBO GAIN button, this setting also enables these controls.

When the monitor is connected to the remote control unit

The MONITOR connector (BNC type) of the RM-B150/B750 outputs the same signal as that from the TEST OUT connector on the camcorder.

Use the black cable supplied with the RM-B150/B750 to connect the monitor to the MONITOR connector on the RM-B150/B750.

When the remote control unit is disconnected from the camcorder

The camcorder settings return to the settings in effect before the remote control unit was connected.

By making a menu setting, the setting of the paint adjustment made with the remote control unit can be retained even after the remote control unit is removed from the camcorder.

For details, see “Structure of the paint adjustment data” below.

Structure of the paint adjustment data

The non-volatile memory of the camcorder used for storing paint adjustment data consists of two regions as shown below: one is the “independent data region” that is used when a remote control unit is not connected, and the other is the “remote control data region” that is used when a remote control unit is connected. Paint adjustment data is automatically selected and output to the hardware of the camcorder depending on whether or not a remote control unit, such as the RM-B150, is connected.

For details on menu operations, see “5-1-2 Basic Menu Operations” on page 76.

To keep the video quality before a remote control unit is connected

Set RM COMMON MEMORY to ON on the FUNCTION 3 menu of the MAINTENANCE menu, and set all the volume on the remote control unit to the relative value mode. After making these settings, connect the remote control unit.

For details, refer to the operation manual supplied with the remote control unit.

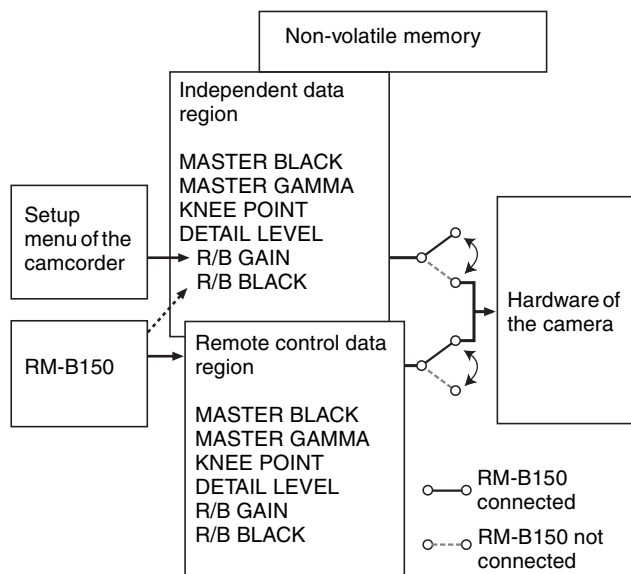

Thus, when a remote control unit is connected to the camcorder, the effective data region is switched to the “remote control data region” and the settings of the paint adjustment that were in effect last time the remote control unit was used are recalled.

Settings of the absolute value volume ¹⁾ and absolute value switches ²⁾ are overwritten by those on the remote control unit after the remote control unit is connected.

When the remote control unit is removed from the camcorder, the “independent data region” becomes effective. Thus the camcorder will return to the settings that were in effect before the remote control unit was connected.

1) Absolute value volume

The data corresponding to the rotation degree (position) of the volume knob is output. The data corresponding to the rotation amount (change) is called the relative value volume.

2) Absolute value switch

Toggle switches or slide switches (except the temporary switches) (or controls) whose positions must coincide with their functions are called absolute value switches.

To use settings of the paint adjustment data stored in the “independent data region” even when you disconnect a remote control unit

Set RM COMMON MEMORY to ON on the FUNCTION 3 page of the MAINTENANCE menu.

In this case, the settings stored in the “independent data region” will be renewed according to the change of settings in the “remote control data region.” Thus, the settings of the paint data made with the remote control unit can be retained even if the remote control unit is removed.

However, if the switch position on the remote control unit differs from the one on the camcorder, the switch position on the camcorder takes precedence over that on the remote control unit.

8-1 Testing the Camcorder Before Shooting

Check the functions of the camcorder before setting out for a shooting session, preferably by operating the camcorder together with a color video monitor.

8-1-1 Preparations for Testing

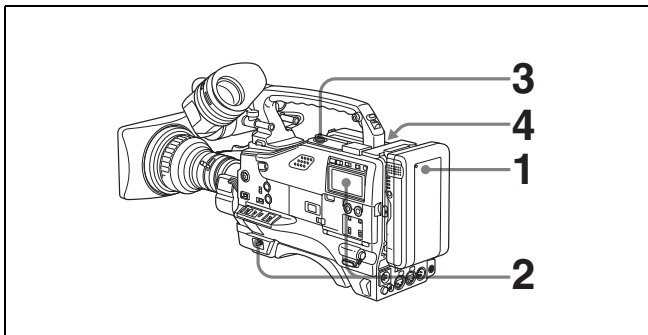

- 1** Attach a fully charged battery pack.
- 2** Set the POWER switch to ON and check that the HUMID indicator does not appear and that the battery power level is sufficient.
If the HUMID indicator appears, wait until it disappears.
- 3** Check that there are no obstructions near the cassette lid, and then press the EJECT button to open the cassette lid.
- 4** After checking the points below, load the cassette and close the cassette lid.
 - The cassette is not write-protected.
 - There is no slack in the tape.
 - Condensation does not form in the tape.

Condensation

If you move the camcorder from a very cold place to a warm place, or use it in a damp location, condensation may form on the head drum. Then, if the camcorder is operated in this state, the tape may adhere to the drum and cause a failure or even permanent damage. Do the following to prevent this from happening.

- When moving the camcorder from a cold place to a warm place, be sure no cassette is loaded in the camcorder.
- Whenever you turn on the power, check that the HUMID indicator does not appear. If it appears, wait until it disappears before loading a cassette.

For more information, see “3-1-1 Loading and Unloading a Cassette” on page 34 and “8-3 Operation Warnings” on page 134.

8-1-2 Testing the Camera

Set the switches and selectors as follows:

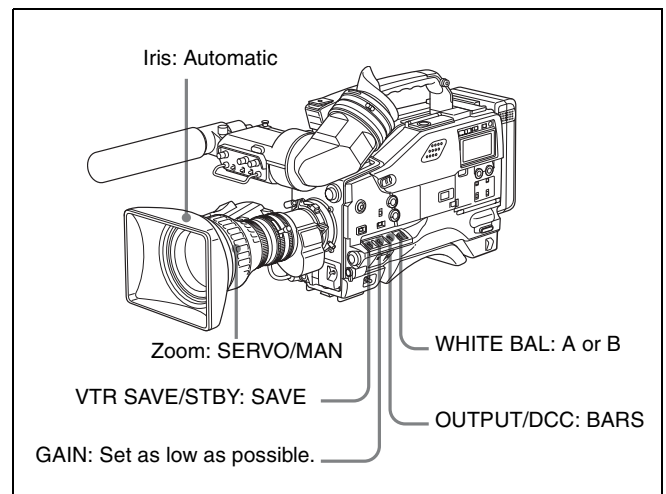

Testing the viewfinder

Proceed as follows:

- 1** Adjust the position of the viewfinder.

2 Check that the color bars are displayed on the viewfinder screen, and adjust the BRIGHT, CONTRAST, and PEAKING controls to give the best color bar display.

3 Check each of the following operations.

- The menu is displayed on the viewfinder screen.
- Turn the MENU knob and check that the menu page changes to the next page.
- Press the MENU knob and check that settings of each item of the selected page are displayed.
- Turn the MENU knob and check that the ► mark moves within the page.
- Press the MENU knob and check that the ► mark placed before the item changes to a ● mark and the ● mark placed before the setting of the item changes to a ? mark.
- Turn the MENU knob and check that the setting of the selected item changes.

4 Set the OUTPUT/DCC switch to CAM, and change the inner FILTER (ND filter) selector position in the sequence of 1, 2, 3 and 4, and the outer FILTER (CC filter) selector position in the sequence B, C, D, A and B.

Check that the FILTER indicator on the viewfinder screen displays the correct numbers.

5 Carry out of the following operations, and check that that the / indicator lights if the corresponding item has been turned on on the '!' LED page of the USER menu.

- Set the gain to anything but 0 dB by using the GAIN selector and the GAIN SW page of the OPERATION menu.
- Set the SHUTTER selector to ON.
- Set the WHITE BAL switch to PRST.
- Use the lens extender.
- Set the inner FILTER (ND filter) selector to anything but 1.
- Set the outer FILTER (CC filter) selector to anything but B.
- Set the iris override to a value other than 0.

6 Move the SHUTTER selector from ON to SEL repeatedly, and check that the shutter setting changes on the viewfinder screen.

7 Pointing the camera at a suitable subject, focus the camera and check the picture on the viewfinder screen.

8 Set both of the AUDIO IN switches to FRONT, and check that when sound is input to a microphone connected to the MIC IN connector on the front of the camcorder, the audio level indicators appear on the viewfinder screen.

9 Check that setting the ZEBRA switch to ON and OFF makes the zebra pattern appear and disappear on the viewfinder screen.

Note

The results of checking in steps **3** to **9** may not be as expected, depending on the settings relating to the viewfinder display function. In this case, set the desired items on the VF DISP 1 and VF DISP 2 pages of the USER menu.

For details, see “5-2-2 Selecting the Display Items” on page 84.

Testing the iris and zoom functions

1 Set the zoom to automatic zoom mode and check that the power zoom operates correctly.

2 Set the zoom to manual zoom mode and check the zoom functions manually.

3 Set the iris switch on the lens to AUTO and point the camera at objects of different brightness. Check that the automatic iris adjustment operates correctly.

4 Set the iris switch on the lens to MANUAL and check that turning the iris ring manually adjusts the iris correctly.

5 Set the iris switch on the lens back to AUTO and check the following points when the GAIN selector is moved from L to M to H.

- For objects of the same brightness, the iris is adjusted to correspond to the change in setting.
- The gain indicator on the viewfinder screen changes to correspond to the change in setting.

6 If an extender mechanism is incorporated in your lens, put the extender lever of the lens into the 2x position and check the following points.

- The indication “EX” appears at the top left on the viewfinder screen.
- The auto iris functions correctly.

8-1-3 Testing the VTR

Perform tests (1) to (7) consecutively.

(1) Testing the tape transport functions

- 1** Set the VTR SAVE/STBY switch to VTR SAVE and check that the SAVE indicator in the viewfinder goes on.
- 2** Set the VTR SAVE/STBY switch to STBY and check that the VTR SAVE indicator in the viewfinder goes off.
- 3** Set the F-RUN/SET/R-RUN to R-RUN.
- 4** Set the DISPLAY switch to CTL.
- 5** Press the VTR START button and check the following points.
 - The tape reels are turning.
 - The counter indication is changing.
 - The REC indicator in the viewfinder is on.
 - The RF and SERVO indicators on the display panel are off.
- 6** Press the VTR START button again and check that the tape stops and that the REC indicator in the viewfinder goes off.
- 7** Repeat the checks of steps **5** and **6**, this time using the VTR button on the lens.
- 8** Press the RESET button and check that the indication in the counter display is "00:00:00:00."
- 9** Turn on the LIGHT switch and check that the display panel is illuminated.
- 10** Hold down the REW button to rewind the tape for a while, then press the PLAY button. Check that the rewind and playback functions operate normally.
- 11** Press the STOP button and press the F FWD button. Check that the fast forward function operates normally.

(2) Testing the automatic audio level adjusting functions

- 1** Set the AUDIO IN CH-1 and CH-2 switches to FRONT.
- 2** Set the AUDIO SELECT CH-1/CH-2 switches to AUTO.

- 3** Set the CH-1/2 / CH-3/4 switch to CH-1/2.
- 4** Aim the microphone connected to the MIC IN connector at a suitable sound source. Check that the level indications for channels 1 and 2 correspond to the sound level, respectively.
- 5** Set the AUDIO IN CH-3 and CH-4 switches to F.
- 6** Set the CH-1/2 / CH-3/4 switch to CH-3/4.
- 7** Aim the microphone connected to the MIC IN connector at a suitable sound source. Check that the level indications for both channels 3 and 4 correspond to the sound level.
- 8** Be sure to reset the CH-1/2 / CH-3/4 switch to CH-1/2 after checking the channels 3 and 4.

(3) Testing the manual audio level adjusting functions

- 1** Set the AUDIO IN CH-1 and CH-2 switches to FRONT.
- 2** Set the AUDIO SELECT CH-1 and CH-2 switches to MANUAL.
- 3** Turn the MIC LEVEL control. Check that the channel-1 and -2 audio level meter in the display panel show more and more segments as you turn the control counterclockwise as seen from the front of the camcorder.

(4) Testing the earphone and speaker

- 1** Turn the MONITOR volume control and check that the speaker volume changes accordingly.
- 2** Connect an earphone to the front or rear EARPHONE jack. Check that the speaker sound is cut off and that you can hear the sound from the microphone in the earphone.
- 3** Turn the MONITOR volume control and check that the earphone volume changes accordingly.
- 4** Connect the earphone to the other EARPHONE jack. Check the earphone as in step **3**.

(5) Testing external microphones.

- 1** Connect external microphones to the AUDIO IN CH1/CH2 connectors.

- 2** Set the LINE/MIC/+48V ON switches as follows:
 - If the connected microphone is of the internal power supply type, set the switch to MIC.
 - If the connected microphone is of the external power supply type, set the switch to +48V ON.
- 3** Set the AUDIO IN switches to REAR.
- 4** Aim the microphones at a sound source.
- 5** Check that the audio level meter in the display panel and the audio level indicators in the viewfinder reflect the changing sound level.

(6) Checking the XLR connection automatic detection function

Before starting to check, remove the front microphone connected to the MIC IN connector if it is connected.

- 1** Perform the operations of steps **1** and **2** explained in (5) “Testing external microphones.”
- 2** Set the AUDIO IN CH1 and CH2 switches to FRONT.
- 3** Perform the operations of steps **4** and **5** explained in (5) “Testing external microphones.”

When performing the operation of step **5** in (5) Testing external microphones, if the audio level meters in the display panel and audio level indicators in the viewfinder reflect the changing sound level, the function of the XLR connection automatic detection works correctly.

If it does not reflect the changing sound level, the function of the XLR connection automatic detection function is off. Set REAR XLR AUTO to “ON” on the AUDIO-1 page of the MAINTENANCE menu.

If it does not reflect even after making this setting, the XLR connection automatic detection function does not work correctly.

(7) Checking the user bit and time code functions

- 1** Set the user bits as required.

For the operation, see “4-5-3 Setting the User Bits” on page 72.
- 2** Set the time code.

For the operation, see “4-5-1 Setting the Time Code” on page 71.
- 3** Set the F-RUN/SET/R-RUN switch to R-RUN.

- 4** Press the VTR START button, and check that recording starts and that the counter indication changes.
- 5** Press the VTR START button again, and check that the tape stops and that the counter indication also stops changing.
- 6** Set the F-RUN/SET/R-RUN switch to F-RUN, and check that the counter indication changes regardless of whether the tape is running.
- 7** Set the DISPLAY switch to DATA and the DATA switch to U-BIT, and check that the user bit data that was set is displayed.

8-2 Maintenance

8-2-1 Cleaning the Video Heads

To clean the video heads, use a Sony BCT-D12CL Cleaning Cassette. Follow the instructions given with the cleaning cassette, as incorrect or excessive use could damage the video heads.

To clean the heads, perform the following:

Load the cleaning cassette according to the procedure described in “Loading a cassette” (page 34).

The tape runs automatically in PLAY mode for about 3 seconds to clean the head.

After the tape runs, the cleaning cassette is automatically ejected.

Note

Do not run the cleaning cassette 5 or more times consecutively.

8-2-2 Cleaning the Viewfinder

Use a dust blower to clean the CRT screen and mirror inside the viewfinder barrel.

Clean the lens and protecting filter with a commercially available lens cleaner.

Caution

Never use organic solvents such as thinner.

Disassembling the eyepiece for cleaning

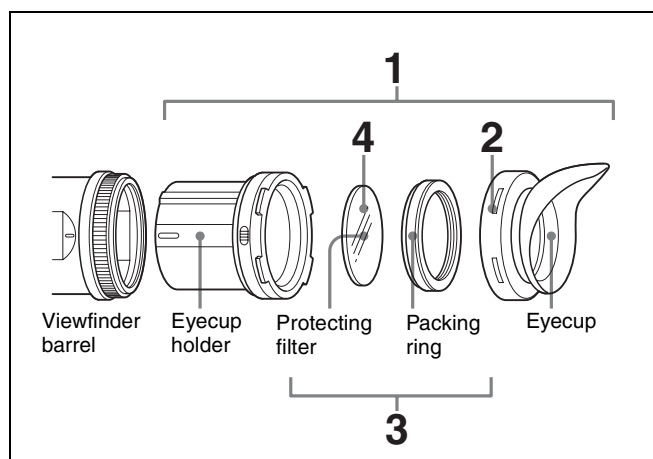

- 1 Detach the eyepiece from the viewfinder barrel.

For the detaching procedure, see “7-2-4 Detaching the Eyepiece” on page 118.

- 2 Remove the eyecup from the eyecup holder.
- 3 Remove the protecting filter, together with the packing ring, from inside the eyecup holder.
- 4 Detach the protecting filter from the packing ring.

Fog-proof filter

Depending on the temperature and humidity, the protecting filter may mist because of vapor or your breath. To ensure that the viewfinder is always clear, replace the protecting filter with a fog-proof filter (Part No. 1-547-341-11, not supplied).

Fitting the fog-proof filter

Replace the protecting filter on the packing ring with the fog-proof filter.

Be sure to correctly assemble the fog-proof filter, the packing ring, and the eyecup so that the reassembled eyepiece is waterproof.

Note

When cleaning the fog-proof filter, wipe it very gently with a soft cloth to avoid damaging the anti-fogging coating.

8-3 Operation Warnings

When a problem occurs at power on or during operation, a warning is given by the relevant indicators in the display

panel, in the viewfinder and on the camcorder body. The speaker and earphone also give audible warnings.

Operation warnings

Display panel		Indicators in viewfinder			Warning sounds	Problem	VTR operation	Action to take
Warning/Battery status indication	Status (Flashing/Lit)	WARNING	REC/tally	BATT				
		☀ : Lit ☀ : 1 flash/s ☀ : 4 flashes/s			●●●●●●●● : 4 beeps/s ●●●●●●●● : 1 beep/s ●●●●●●●●●● : Continuous beep			
RF	Lit ¹⁾	☀	☀	—	●●●●●●●● ¹⁾	Video head gap clogged or problem in recording circuit	After clogged head is detected, recording continues but may be substandard.	Clean the head. If recording is still substandard, turn off the power, and consult your Sony service representative
SERVO	Lit	☀	☀	—	●●●●●●●●	Servo lock lost	Recording continuous but may be substandard.	Turn off the power and contact your Sony service representative. (This indication may be given momentarily when the tape starts moving, but this does not indicate a problem.)
HUMID!	Lit	☀	☀	—	●●●●●●●● ¹⁾ ●●●●●●●●●● ²⁾	Condensation on the optical pickup.	Recording continues but stops if the tape sticks to the head drum. Playback, fast forward, and rewind do not operate.	Stop the tape, and wait until the HUMID indicator disappears.
SLACK	Lit	☀	☀	—	●●●●●●●●●●	The tape cannot be wound properly.	VTR stops. An error code appears in the time code display section of the display panel. Look up the error code in the Maintenance Manual.	Remove the cassette by the method described in the Maintenance Manual. Close the cassette lid without loading a cassette, turn off the power, and consult your Sony service representative.
TAPE	Flashing ⁴⁾	☀ ¹⁾	☀		●●●●●●●●	Near the end of tape	Operation continues.	Be prepared to change the cassette.
TAPE and E	Flashing	☀	☀		●●●●●●●●●●	End of tape	Recording stops.	Change the cassette.
BATT	Flashing	☀	☀	☀	●●●●●●●● ⁴⁾	Battery almost exhausted.	Operation continues. ⁵⁾	Change the battery.
BATT and E	Flashing	☀	☀	☀	●●●●●●●●●●	Battery exhausted.	Operation stops.	Change the battery.

1) During recording

2) During playback, fast forward, or stop

3) Additionally "5-0" appears for the tape remaining indication.

4) During recording or in stop mode

5) The VTR once stops recording in auto interval recording mode.

Operation/error messages

An operation or error message is displayed in the operation/error message display area (*see page 82*) in the viewfinder.

Operation/error message	Meaning
AUTO INTERVAL **M**S	Indicates the camera is in the Auto Interval Rec mode. **M**S indicates the shooting interval.
MANU INTERVAL *FRAME	Indicates the camera is in the single shot mode of the Manual Interval Rec mode. *FRAME indicates the number of frames.
INTERVAL **S(M/ H)*FRAME	Indicates the camera is in the consecutive mode of the Manual Interval Rec mode. **S(M/H) indicates the trigger interval and *FRAME indicates the number of frames.
40Mbps (30Mbps)	Indicates the recording bit rates. When the recording bit is set to 50M, 50Mbps is not displayed.
LOW LIGHT	Appears, if set to ON on the menu, to indicate the subject illumination is inadequate.
TAPE REC INH.	Appears when recording on a write-protected cassette.
TELE FILE MEMORY FULL	Appears when you load a cassette with a full memory label.
TELE FILE NEAR FULL	Appears when you load a cassette with a memory label that is nearly full.
Retake Search Failed	Appears when the camcorder fails to position the tape at recording starting point when recording using the RE-TAKE function. ¹⁾
Humid Disturbed INT REC	Appears when there are portions where recording has failed due to condensation while shooting pictures at intervals (using the interval rec function).
INVALID OPERATION	Appears when: <ul style="list-style-type: none"> • there is only one recorded cut when recording using the RE-TAKE function. • the recorded cuts are less than 3 sec. when recording using the RE-TAKE function. • the RE-TAKE function was denied for some reason, e.g. as Picture Cache was on. • when you execute the RE-TAKE operation before the recording pause operation has completed.
ON-BOARD BATTERY EMPTY	Appears when the backup battery for the internal clock has been used up. ²⁾

1) In this case, position the tape at the point where you want to start the recording manually.

2) To replace the backup battery, contact your nearest Sony dealer.

Phenomena specific to CCD image sensors

The following phenomena that may appear in images are specific to CCD (Charge Coupled Device) image sensors. They do not indicate malfunctions.

White flecks

Although the CCD image sensors are produced with high-precision technologies, fine white flecks may be generated on the screen in rare cases, caused by cosmic rays, etc. This is related to the principle of CCD image sensors and is not a malfunction.

The white flecks especially tend to be seen in the following cases:

- when operating at a high environmental temperature
- when you have raised the master gain (sensitivity)
- when operating in Slow-Shutter mode

This product has a compensation function and the problem may be alleviated by automatic black balance adjustment (*see page 60*).

Vertical smear

When an extremely bright object, such as a strong spotlight or flashlight, is being shot, vertical tails may be produced on the screen, or the image may be distorted.

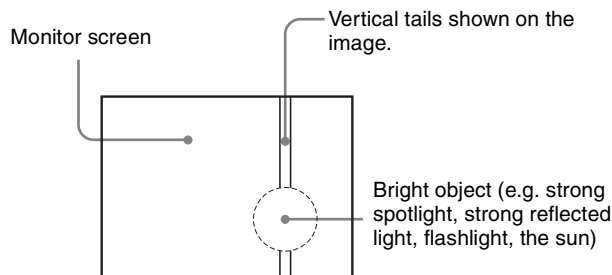

Aliasing

When fine patterns, stripes, or lines are shot, they may appear jagged or flicker.

Appendixes

Specifications

General

Power voltage	12 V DC +5.0/-1.0 V
Power consumption	Approx. 27 W (with 12 V DC supply, when recording)
Operating temperature	0°C to +40°C (32°F to 104°F)
Operating humidity	25% to 85% (relative humidity)
Storage temperature	-20°C to +60°C (-4°F to +140°F)
Mass	Approx. 5.4 kg (12 lb 2 oz) (with microphone, viewfinder, BCT-60MX cassette and BP-GL95 Battery Pack)

Dimensions in mm (inches)

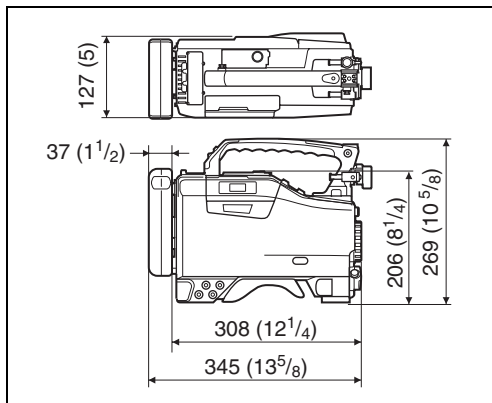

Supplied accessories

- Shoulder strap (1)
- Microphone (super cardioid directional, external power supply type) (1)
- Lens mount securing rubber (1)
- Operation guide
 - Japanese version (1) (MSW-970 only)
- Operation manual
 - English version (1)
 - CD-ROM manual (1)

Video Camera Section

General

Imager	$\frac{2}{3}$ -inch type CCD with 1,000,000 pixels
Effective picture elements	980 (H) × 988 (V) with MSW-970 980 (H) × 1164 (V) with MSW-970P
Imager Configuration	RGB 3 CCDs
Spectral system	F1.4 prism system (with quartz filter)
Built-in filters	CC filter <ul style="list-style-type: none"> A: Cross filter B: 3200K C: 4300K D: 6300K
	ND filter <ul style="list-style-type: none"> 1: Clear 2: $\frac{1}{4}$ ND 3: $\frac{1}{16}$ ND 4: $\frac{1}{64}$ ND
Lens mount	Special bayonet mount
Sensitivity	F11 standard (89.9% reflection chart, 2000 lx)
Minimum illumination	0.008 lx (at F1.4, +48 dB gain, 16-frame slow shutter)
Video S/N ratio	65 dB (Y typical) (for the MSW-970) 63 dB (Y typical) (for the MSW-970P)
Modulation (at screen center)	4:3 mode: 55% 16:9 mode: 70%
Registration	0.05% or less for entire screen area (excluding distortion due to lens)
Geometric distortion	None identified (excluding distortion due to lens)
Smear	-145 dB (Y-typical)

Viewfinder

CRT	2-inch monochrome, quick start type
Horizontal resolution	4:3 mode: 600 TV lines (at screen center)
	16:9 mode: 450 TV lines (at screen center)

VTR Section

General

Usable cassette tapes	BCT-6MX/12MX/22MX/32MX/60MX 1/2-inch MPEG IMX cassette tapes
Tape speed	Approx. 64.467 mm/s (at 30 frames) (for the MSW-970) Approx. 53.776 mm/s (at 25 frames) (for the MSW-970P)
Record/playback time	60 minutes (using BCT-60MX video cassette) (MSW-970) 71 minutes (using BCT-60MX video cassette) (MSW-970P)
Fast forward time	Approx. 5 minutes (using BCT-60MX video cassette)
Rewind time	Approx. 5 minutes (using BCT-60MX video cassette)
Continuous recording time	Approx. 180 minutes (using BP-GL95 Battery Pack) Approx. 120 minutes (using BP-GL65 Battery Pack)

Digital video

Sampling frequency	Y: 13.5 MHz R-Y/B-Y: 6.75 MHz
Quantization	10 bits/sample (8 bits/sample for compression processing)
Compression	MPEG-2 4:2:2P@ML 50 Mbps
Channel coding	S-NRZI PR-IV
Error correction	Reed-Solomon code

Audio (with standard playback machine)

Frequency response	20 Hz to 20 kHz +0.5/-1.0 dB
Dynamic range	85 dB min. (emphasis ON)
Distortion (THD)	0.08% max.
Cross talk	-70 dB max.
Wow and flutter	Below measurable limit

Input/output connectors

Signal inputs

AUDIO IN CH1/CH2	XLR type, 3-pin, female -60 dBu/-50 dBu/+4 dBu (0 dBu = 0.775 Vrms.)
MIC IN	XLR type, 3-pin, female -60 dBu/-50 dBu
GENLOCK IN	BNC type 1.0 Vp-p, 75 Ω , unbalanced
TC IN	BNC type 0.5 V to 18 Vp-p, 10 k Ω

Signal outputs

TEST OUT	BNC type 1.0 Vp-p, 75 Ω , unbalanced
VIDEO OUT	BNC type, 75 Ω , unbalanced VBS OUT: 1.0 Vp-p SDI OUT: 0.8 Vp-p (only when the CBK-SD01 is installed)
AUDIO OUT	XLR type, 5-pin, male, 0 dBm
TC OUT	BNC type, 1.0 Vp-p, 75 Ω
EARPHONE	minijack 8 Ω , $-\infty$ to -18 dBs variable

Others

DC IN	XLR type, 4-pin, male, 11 to 17 V DC
DC OUT	4-pin, 11 to 17 V DC, maximum rated current 0.1 A
LENS	12-pin
REMOTE	8-pin

Recommended Additional Equipment

Power supply and related equipment

BP-GL65/GL95/L60S Battery Pack
BC-M50/M150 Battery Charger
AC-550/550CE AC Adaptor
AC-DN10 AC Adaptor

MPEG IMX cassette tapes

BCT-6MX/12MX/22MX/32MX/60MX

Memory label

MLB-M-100

Viewfinder and related equipment

BKW-401 Viewfinder Rotation Bracket
Fog-proof filter (Part No. 1-547-341-11)
Lens assembly (farsighted) (Part No. A-8262-537-A)

Lens assembly (low magnification) (Part No. A-8262-538-A)
Lens assembly (standard magnification with special compensation for aberrations) (Part No. A-8267-737-A)

Optical attachments

ND filter ($\frac{1}{8}$ ND) (Part No. 3-174-685-01)
ND filter ($\frac{1}{32}$ ND) (Part No. 3-174-683-01)

Consult your Sony representative for more information about these filters.

Equipment for remote control

RM-B150/B750 Remote Control Unit

Wireless video/audio transmission

WLL-CA50 Wireless Camera Transmitter

“Memory Stick”

MSH-32 (32 MB)
MSH-64 (64 MB)
MSH-128 (128 MB)

Audio equipment

ECM-672 Microphone
CAC-12 Microphone Holder
CCXA-53 Audio Cable (for converting 5-pin connector to two 3-pin connectors)
WRR-855A/855B UHF Synthesized Tuner Unit
WRR-860/862 UHF Portable Tuner
WRT-850/860 UHF Transmitter
WRR Tuner Fitting (service part number: A-8278-057-A)

For Audio equipment described above, confirm whether the connector is male or female and the number of pins on the connector.

The audio input connectors of the camcorder are female and 3-pin and the audio output connectors are male and 5-pin. A converting adaptor may be required depending on the audio equipment to be connected to the camcorder.

Extension boards

CBK-FC01 Pull Down (24P) Board (for the MSW-970 only)
CBK-SD01 SDI Output Board
MSDW-903 Picture Cache Board
MSDW-904 Analog Composite Input Board

Equipment for maintenance and easier handling

BCT-D12CL Cleaning Cassette
LC-DN7 Hard Carrying Case

LC-DS300SFT Soft Carrying Case
Tripod Adaptor VCT-14
Rain cover (Part No. 3-191-064-02)
Maintenance Manual

Design and specifications are subject to change without notice.

Notes

- Always make a test recording, and verify that it was recorded successfully.
SONY WILL NOT BE LIABLE FOR DAMAGES OF ANY KIND INCLUDING, BUT NOT LIMITED TO, COMPENSATION OR REIMBURSEMENT ON ACCOUNT OF FAILURE OF THIS UNIT OR ITS RECORDING MEDIA, EXTERNAL STORAGE SYSTEMS OR ANY OTHER MEDIA OR STORAGE SYSTEMS TO RECORD CONTENT OF ANY TYPE.
- Always verify that the unit is operating properly before use. SONY WILL NOT BE LIABLE FOR DAMAGES OF ANY KIND INCLUDING, BUT NOT LIMITED TO, COMPENSATION OR REIMBURSEMENT ON ACCOUNT OF THE LOSS OF PRESENT OR PROSPECTIVE PROFITS DUE TO FAILURE OF THIS UNIT, EITHER DURING THE WARRANTY PERIOD OR AFTER EXPIRATION OF THE WARRANTY, OR FOR ANY OTHER REASON WHATSOEVER.

Menu List

This section briefly explains menus that the camcorder provides for adjustments and settings using tables.

For the menu organization and the USER menu, see Chapter 5.

OPERATION Menu

The following table lists and describes the items in the OPERATION menu. Some pages of the OPERATION menu have been registered in the USER menu at the factory. These pages are indicated by a circle (○) in the USER menu column. The USER MENU CUSTOMIZE menu allows you to add and delete pages in the USER menu to suit your requirements.

When the setting range in the Settings column is surrounded by parentheses (), the setup value is a relative value. The setting range shown on the menu screen may differ from what is shown in the manual.

USER menu	No.	Page	Item	Settings	Default	Description
○	01	OUTPUT SEL	REAR BNC OUT SEL	VBS/SDI	VBS	See "5-3-2 Selecting the Output Signals" on page 93.
○	02	TEST OUT	TEST OUT MARKER	OFF/ON	OFF	Selects whether or not the marker signal is mixed to the output signal from the TEST OUT connector.
			TEST OUT VFDISP	OFF/ON	OFF	Selects whether or not the VF DISP display signal is mixed to the output signal from the TEST OUT connector.
			TEST OUT MENU	OFF/ON	OFF	Selects whether or not the MENU display signal is mixed to the output signal from the TEST OUT connector.
			TEST OUT ZEBRA	OFF/ON	OFF	Selects whether or not the ZEBRA display signal is mixed to the output signal from the TEST OUT connector.
			TEST OUT TC	OFF/ON	OFF	Selects whether or not a time code signal is mixed to the output signal from the TEST OUT connector.
			TEST OUT SELECT	ENC/R/G/B	ENC	Selects the output signal of TEST OUT.

USER menu	No.	Page	Item	Settings	Default	Description
○	03	FUNCTION 1	ASSIGN SW <1>	OFF/CACHE/ CHARA/MARKR/ RTAKE/ATW/RET.V/ RET/REC/TURBO/ D5600/ZEBRA etc.	ATW	<i>See "5-3-5 Assigning Functions to Assignable Switches" on page 95.</i>
			ASSIGN SW <2>	OFF/CACHE/ CHARA/MARKR/ EXT. V/ZEBRA/5600 etc.	OFF	
			TURBO SW	OFF/CACHE/ CHARA/MARKR/ RTAKE/ATW/RET.V/ RET/REC/TURBO/ D5600/ZEBRA etc.	TURBO	
			DF/NDF (MSW-970 only)	DF/NDF	DF	Switches between drop frame (DF) mode and non-drop frame (NDF) mode.
			END SEARCH	ON/OFF	OFF	Turns the END SEARCH function on/off.
			CACHE/INTVAL REC	OFF/CACHE/A.INT/ M.INT	OFF	<i>See "3-2-4 Starting a Shoot with a Few Seconds of Pre-Stored Picture Data (Picture Cache Function: with MSDW-903)" on page 41.</i>
			(CACHE) CACHE REC TIME	0/1/2/3/4/5/6/8 SEC	0 SEC	
			(A.INT) TAKE TOTAL TIME	5/10/15/20/30/40/50 MIN, 1/2/3/4/5/7/10/15/20/ 30/40/50/70/100 H	5 MIN	<i>See "3-2-5 Shooting Picture at Intervals (Interval Rec Function: with MSDW-903)" on page 43.</i>
			(A.INT) REC TIME	5/10/15/20/30/40/50 SEC, 1 to 60 MIN (MSW-970)	5 SEC	
				5/10/15/20/30/40/50 SEC, 1 to 72 MIN (MSW-970P)		
			(M.INT except TRIGGER INTERVAL=M) PRE-LIGHTING	OFF/2SEC/5SEC/ 10SEC	OFF	
			(M.INT) NUMBER OF FRAME	1/2/4/8	1	
			(M.INT) TRIGGER INTERVAL	M, 1 to 10/15/20/30/ 40/50 SEC, 1 to 10/15/20/30/40/ 50 MIN, 1/2/3/4/6/12/24 H	M	

USER menu	No.	Page	Item	Settings	Default	Description
	04	FUNCTION 2	D5600	OFF/ON	OFF	Turns on and off the function which electrically applies a 5600K color temperature filter.
			WIDE AWB	OFF/ON	ON	Turns on and off the function which widens the range adjustable by Auto White Balance.
			WHITE SWITCH 	MEM/ATW	MEM	Sets the function of the WHITE BAL B switch.
			SHOCKLESS WHITE	OFF/1/2/3	1	Changes the white gain smoothly when operating the WHITE BAL switch.
			ATW SPEED	1 to 5	4	Changes the speed of the Auto Tracing White operation.
			LOW LIGHT	OFF/ON	OFF	Turns the warning display on/off when the video average level is less than the preset value.
			LOW LIGHT LEVEL	(-99 to +99)	0	Sets the level at which the LOW LIGHT function becomes effective.
			VF BATT WARNING	10/20%	10%	Sets the threshold value of remaining battery capacity to make the remaining capacity indication flash.
○	05	VF DISP 1	VF DISP	OFF/ON	OFF	<i>See "5-2-2 Selecting the Display Items" on page 84.</i>
			VF DISP MODE	1/2/3	3	
			DISP EXTENDER	OFF/ON	ON	
			DISP FILTER	OFF/ON	ON	
			DISP WHITE	OFF/ON	ON	
			DISP GAIN	OFF/ON	ON	
			DISP SHUTTER	OFF/ON	ON	
			DISP AUDIO	OFF/ON	ON	
			DISP TAPE	OFF/ON	ON	
			DISP IRIS	OFF/ON	ON	
○	06	VF DISP 2	DISP ZOOM	OFF/ON	ON	<i>See "5-2-2 Selecting the Display Items" on page 84.</i>
			DISP COLOR TEMP	OFF/ON	OFF	
			DISP BATT REMAIN	INT/VOLT/AUTO	INT	
			DISP DC IN	OFF/ON	OFF	
			DISP 16:9/4:3 ID	OFF/ON	OFF	
			DISP WRR RF LVL	OFF/ON	OFF	
			DISP E. MARK IND	OFF/ON	OFF	
			DISP TIME CODE	OFF/ON	OFF	
			DISP VIDEO RATE	OFF/ON	ON	

USER menu	No.	Page	Item	Settings	Default	Description
○	07	"!LED	GAIN <!>	OFF/ON	ON	See "2-9 Indicators in the Viewfinder" on page 33.
			SHUTTER <!>	OFF/ON	ON	
			WHT PRESET<!>	OFF/ON	ON	
			ATW RUN <!>	OFF/ON	ON	
			EXTENDER <!>	OFF/ON	ON	
			FILTER <!>	OFF/ON	OFF	
			OVERRIDE <!>	OFF/ON	ON	
○	08	MARKER 1	MARKER	OFF/ON	OFF	See "5-2-4 Setting the Marker Display" on page 86.
			CENTER	OFF/ON	OFF	
			SAFETY ZONE	OFF/ON	OFF	
			SAFETY AREA	80/90/92/95%	90%	
			ASPECT	OFF/ON	OFF	
			ASPECT SELECT	14:9/13:9/4:3	4:3	
			ASPECT MASK (4:3)	OFF/ON	OFF	
			ASPECT MASK LVL	1/2, 1/4, 1/8	1/4	
			100% MARKER	OFF/ON	OFF	
	09	MARKER 2	USER BOX	OFF/ON	OFF	Turns the box cursor on/off.
			USER BOX WIDTH	1 to 465	245	Adjusts the width (from the center to right or left side) of the box cursor.
			USER BOX HEIGHT	1 to 120 (MSW-970)	72	Adjusts the height (from the center to top or bottom) of the box cursor.
				1 to 142 (MSW-970P)	85	
			USER BOX H POS.	-461 to +461	0	Adjusts the H position of the center.
			USER BOX V POS.	-118 to +118 (MSW-970)	0	Adjusts the V position of the center.
				-141 to +140 (MSW-970P)		
			CENTER H POS.	-48 to +47	0	Adjusts the H position of the center marker.
CENTER V POS.	-15 to +14	0	Adjusts the V position of the center marker.			
○	10	GAIN SW	GAIN LOW	-3/0/3/6/9/12/18/24/30/36/42/48	0	See "5-3-1 Setting Gain Values for the GAIN Selector Positions" on page 92.
			GAIN MID		9	
			GAIN HIGH		18	
			GAIN TURBO		42	
			TURBO SW IND	OFF/ON	OFF	
○	11	VF SETTING	ZEBRA	OFF/ON	OFF	See "5-2-5 Setting the Viewfinder" on page 86.
			ZEBRA SELECT	1/2/BOTH	1	
			ZEBRA1 DET.LEVEL	20 to 107	70%	
			ZEBRA1 APT.LEVEL	1 to 20	10%	
			ZEBRA2 DET.LEVEL	52 to 109	100%	
			VF DTL LEVEL	(-99 to +99)	0	
			VF ASPECT	AUTO/16:9	AUTO	

USER menu	No.	Page	Item	Settings	Default	Description
○	12	AUTO IRIS	IRIS OVERRIDE	OFF/ON	OFF	See "4-3 Changing the Reference Value for Automatic Iris Adjustment" on page 67.
			IRIS SPEED	(-99 to +99)	0	
			CLIP HIGH LIGHT	OFF/ON	OFF	
			IRIS WINDOW	1/2/3/4/5/6/VAR	1	
			IRIS WINDOW IND.	OFF/ON	OFF	
			IRIS VAR WIDTH	20 to 465	245	
			IRIS VAR HEIGHT	17 to 120 (MSW-970)	72	
				20 to 142 (MSW-970P)	85	
			IRIS VAR H POS.	-447 to +446	0	
			IRIS VAR V POS.	-104 to +104 (MSW-970)	0	
-124 to +123 (MSW-970P)						
○	13	SHOT ID	ID-1	12 characters	—	See "5-2-7 Setting the Shot ID" on page 88.
			ID-2			
			ID-3			
			ID-4			
○	14	SHOT DISP	SHOT DATE	OFF/ON	OFF	See "5-2-6 Recording Shot Data Superimposed on the Color Bars" on page 87.
			SHOT TIME	OFF/ON	OFF	
			SHOT MODEL NAME	OFF/ON	OFF	
			SHOT SERIAL NO	OFF/ON	OFF	
			SHOT ID SEL	OFF/ID-1/ID-2/ID-3/ID-4	OFF	
			SHOT 16:9 ID	OFF/ON	OFF	
SHOT BLINK CHARA	OFF/ON	OFF				
○	15	SET STATUS	STATUS ABNORMAL	OFF/ON	ON	See "5-2-8 Displaying the Status Confirmation Windows" on page 89.
			STATUS FUNCTION	OFF/ON	ON	
			STATUS AUDIO	OFF/ON	ON	
	16	OFFSET WHT	OFFSET WHITE <A>	OFF/ON	OFF	See "5-3-4 Specifying an Offset for the Auto White Balance Setting" on page 94.
			WARM COOL <A>	Display color temperature	3200	
			COLOR FINE <A>	(-99 to +99)	0	
			OFFSET WHITE 	OFF/ON	OFF	
			WARM COOL 	Display color temperature	3200	
COLOR FINE 	(-99 to +99)	0				

USER menu	No.	Page	Item	Settings	Default	Description	
	17	SHT ENABLE	SHUTTER SLS	OFF/ON	ON	<p>See "4-2 Setting the Electronic Shutter" on page 63.</p> <p>The items which can be set differ depending on the CCD scan mode setting (see page 99).</p>	
			SHUTTER ECS	OFF/ON	ON		
			SHUTTER 1/32	OFF/ON	ON		
			SHUTTER 1/33	OFF/ON	ON		
			SHUTTER 1/40	OFF/ON	ON		
			SHUTTER 1/48	OFF/ON	ON		
			SHUTTER 1/50	OFF/ON	ON		
			SHUTTER 1/60	OFF/ON	ON		
			SHUTTER 1/96	OFF/ON	ON		
			SHUTTER 1/100	OFF/ON	ON		
			SHUTTER 1/120	OFF/ON	ON		
			SHUTTER 1/125	OFF/ON	ON		
			SHUTTER 1/250	OFF/ON	ON		
			SHUTTER 1/500	OFF/ON	ON		
			SHUTTER 1/1000	OFF/ON	ON		
			SHUTTER 1/2000	OFF/ON	ON		
○	18	LENS FILE	LENS FILE SELECT	1 to 17*	1	<p>See "5-3-7 Selecting the Lens File" on page 98.</p> <p>*: "17" can be selected only when a lens having serial transmission ability is mounted.</p>	
			F.ID	(Display only)	—		
			L. ID	(Display only)	—		To show the lens-specific ID (when a serial lens is connected).
			L. MF	(Display only)	—		To show the name of the lens manufacturer (when a serial lens is connected).
	19	FORMAT	16:9/4:3 SELECT	16:9/4:3	16:9	See "5-3-8 Selecting the Aspect Ratio" on page 98.	
			SCAN MODE	I/PsF/24P (24P is selectable only when CBK-FC01 is connected.)	I	See "5-3-9 Setting the CCD Scan Mode" on page 99.	
			V LPF (24P/30P) (only when CBK-FC01 is connected)	OFF/ON	ON	See "5-3-9 Setting the CCD Scan Mode" on page 99.	
			UC/J SELECT (MSW-970 only)	UC/J	UC	Selects the signal format.	
	20	SOURCE SEL	REC VIDEO SOURCE	CAM/EXT	CAM	See "3-5 Recording Video Signals from External Equipment (When Using an MSDW-904)" on page 55.	
			EXT OUTPUT DELAY	SYNC/VIDEO	SYNC		
			SETUP REMOVE (MSW-970 only)	0.0/7.5	7.5		

USER menu	No.	Page	Item	Settings	Default	Description
	21	UMID SET	EX-OWNERSHIP REC	OFF/ON	OFF	<i>See "5-3-10 Using UMID Data" on page 101.</i>
			COUNTRY CODE	4-byte alphanumeric strings	—	
			ORGANIZATION	4-byte alphanumeric strings	—	
			USER CODE	4-byte alphanumeric strings	—	
			INSTANCE NO	RND/GEN	RND	
			TIME ZONE : 00	00 to 25, 1A to 1F, 2A to 2F, 32, 3A to 3F	00	
			MACHINE	<i>n</i>	—	

PAINT Menu

The following table lists and describes the items in the PAINT menu.

When the setting range in the Settings column is surrounded by parentheses (), the setup value is a relative

value. The setting range shown on the menu screen may differ from what is shown in the manual.

No.	Page	Item	Settings	Default	Description
P01	SW STATUS	GAMMA	OFF/ON	ON	Turns the gamma correction on/off.
		CHROMA	OFF/ON	ON	Turns the chroma of the composite signal on/off.
		MATRIX	OFF/ON	ON	Turns the linear matrix correction on/off.
		KNEE	OFF/ON	ON	Turns the knee correction on/off.
		WHITE CLIP	OFF/ON	ON	Turns the white clipping correction on/off.
		DETAIL	OFF/ON	ON	Turns the detail signal on/off.
		APERTURE	OFF/ON	ON	Turns the aperture function on/off.
		FLARE	ON/OFF	ON	Turns the flare function on/off.
		EVS	OFF/ON	OFF	Turns the EVS shutter on/off.
		TEST SAW	OFF/REC/SAW	OFF	Selects the test signal.
P02	WHITE	COLOR TEMP <A>	Display color temperature	3200	Sets the color temperature of WHITE A.
		COLOR FINE <A>	(-99 to +99)	0	Adjusts the value more precisely when the color temperature adjustment through COLOR TEMP is not satisfactory.
		R GAIN <A>	(-99 to +99)	0	Only the value of R GAIN is changed.
		B GAIN <A>	(-99 to +99)	0	Only the value of B GAIN is changed.
		D5600K <A>	OFF/ON	OFF	Turns the WHITE A electronic 5600K filter on/off.
		COLOR TEMP 	Display color temperature	3200	Sets the color temperature of WHITE B.
		COLOR FINE 	(-99 to +99)	0	Adjusts the value more precisely when the color temperature adjustment through COLOR TEMP is not satisfactory.
		R GAIN 	(-99 to +99)	0	Only the value of R GAIN is changed.
		B GAIN 	(-99 to +99)	0	Only the value of B GAIN is changed.
		D5600K 	OFF/ON	OFF	Turns the WHITE B electronic 5600K filter on/off.
P03	BLACK/FLARE	MASTER BLACK	(-99 to +99)	0	Adjusts the master black level.
		R BLACK	(-99 to +99)	0	Adjusts the R black level.
		B BLACK	(-99 to +99)	0	Adjusts the B black level.
		MASTER FLARE	(-99 to +99)	0	Adjusts the flare level of the master.
		R FLARE	(-99 to +99)	0	Adjusts the R flare level.
		G FLARE	(-99 to +99)	0	Adjusts the G flare level.
		B FLARE	(-99 to +99)	0	Adjusts the B flare level.
		FLARE	OFF/ON	ON	Turns the flare correction circuit on/off.
		TEST OUT SELECT	ENC/R/G/B	ENC	Selects the output signal of TEST OUT connector.

No.	Page	Item	Settings	Default	Description
P04	GAMMA	GAMMA	OFF/ON	ON	Turns the gamma correction function on/off.
		STEP GAMMA	0.35 to 0.90	0.45	Sets the master gamma correction curve in steps.
		MASTER GAMMA	(-99 to +99)	0	Sets the master gamma correction curve.
		R GAMMA	(-99 to +99)	0	Sets the R gamma correction curve.
		G GAMMA	(-99 to +99)	0	Sets the G gamma correction curve.
		B GAMMA	(-99 to +99)	0	Sets the B gamma correction curve.
		TEST OUT SELECT	ENC/R/G/B	ENC	Selects the output signal of TEST OUT connector.
		GAMMA SELECT	STD/FILM	STD	Selects the gamma table.
		GAM SEL (STD)	1 to 6	3	Selects the gamma table of STD.
GAM SEL (FILM)	1 to 5	1	Selects the gamma table of FILM.		
P05	BLACK GAMMA	BLACK GAMMA	OFF/ON	OFF	Turns the black gamma correction on/off.
		BLACK GAM RANGE	LOW/L.MID/ H.MID/HIGH	HIGH	Sets the range affected by black gamma.
		MASTER BLK GAMMA	(-99 to +99)	0	Adjusts the master black gamma.
		R BLACK GAMMA	(-99 to +99)	0	Sets the correction curve of the R black gamma.
		G BLACK GAMMA	(-99 to +99)	0	Sets the correction curve of the G black gamma.
		B BLACK GAMMA	(-99 to +99)	0	Sets the correction curve of the B black gamma.
		TEST OUT SELECT	ENC/R/G/B	ENC	Selects the output signal of TEST OUT connector.
P06	KNEE	KNEE	OFF/ON	ON	Turns the knee correction circuit on/off.
		KNEE POINT	50 to 109%	85.0	Sets the knee point level.
		KNEE SLOPE	(-99 to +99)	0	Set the knee slope level.
		KNEE SATURATION	OFF/ON	ON	Turns the knee saturation function on/off.
		KNEE SAT LEVEL	(-99 to +99)	0	Sets the knee saturation level.
		WHITE CLIP	OFF/ON	ON	Turns the white clipping function on/off.
		WHITE CLIP LEVEL	100.0 to 109.5%	109.0 (MSW- 970)/ 105.0 (MSW- 970P)	Adjusts the white clipping level.
P07	DETAIL 1	DETAIL	OFF/ON	ON	Sets the detail correction function on/off.
		APERTURE	OFF/ON	ON	Turns the aperture correction function on/off.
		DETAIL LEVEL	(-99 to +99)	0	Sets the general level of the detail signal.
		APERTURE LVL	(-99 to +99)	0	Sets the aperture level.
		DTL H/V RATIO	(-99 to +99)	0	Sets the level of the V detail signal.
		CRISPENING	(-99 to +99)	0	Sets the crispening level.
		LEVEL DEPEND	OFF/ON	ON	Turns the level depend function on/off.
		LEVEL DEPEND LVL	(-99 to +99)	0	Sets the level of the level depend.
DETAIL FREQUENCY	(-99 to +99)	0	Sets the frequency of the H detail signal.		

No.	Page	Item	Settings	Default	Description
P08	DETAIL 2	KNEE APERTURE	OFF/ON	OFF	Turns the knee aperture function on/off.
		KNEE APT LVL	(-99 to +99)	0	Sets the knee aperture level.
		DETAIL COMB	(-99 to 0)	0	Sets the level at which the comb filter becomes effective.
		CROSS COLOR	ON/OFF	OFF	Turns the cross color component on/off.
		CROSS COLOR LVL	0 to 99	43	Sets the suppression level of the cross color.
		DETAIL LIMIT	(-99 to +99)	0	Sets the both detail black and white limiters.
		DTL WHT LIMIT	(-99 to +99)	0	Sets the detail white limiter.
		DTL BLK LIMIT	(-99 to +99)	0	Sets the detail black limiter.
		DTL V-BLK LMT	(-99 to +99)	0	Sets the V detail black limiter.
P09	DETAIL 3	FINE DTL	OFF/ON	OFF	Turns the fine detail function on/off.
		FINE DTL LVL	(-99 to +99)	0	Sets the level at which the fine detail function becomes effective.
		V DTL CREATION	NAM/G/R+G/Y	R+G	Selects the source signal of the V DTL signal.
		H/V CONTROL MODE	H/V / V	V	Select the operation mode of DETAIL H/V RATIO on the DETAIL 1 page. (H/V: H and V both enabled, V: V DTL only enabled)
P10	SKIN DETAIL	SKIN DETAIL ALL	OFF/ON	OFF	Turns on all of 1, 2 and 3 of the color detail function.
		SKIN DETECT	Moves to color detection page.	EXEC	Executes the color detail function.
		SKIN AREA IND	OFF/ON	OFF	Turns the zebra indication on/off in the area of the currently selected type of the color detail function.
		SKIN DTL SELECT	1/2/3	1	Selects the channels to be displayed on the menu.
		SKIN DETAIL	OFF/ON	ON	Turns the color detail function on/off for the selected channels.
		SKIN DETAIL LVL	(-99 to +99)	0	Sets the level of the color detail signal.
		SKIN DTL SAT	(-99 to +99)	0	Adjusts the saturation level of the hue possessed by the color detail function.
		SKIN DTL HUE	(0 to 359)	0	Adjusts the center phase of the hue possessed by the color detail function.
		SKIN DTL WIDTH	(0 to 359)	40	Adjusts the width of the hue possessed by the color detail function.

No.	Page	Item	Settings	Default	Description
P11	MTX LINEAR	MATRIX	OFF/ON	ON	Turns the linear matrix correction and user-set matrix correction functions on/off.
		MATRIX (USER)	OFF/ON	OFF	Turns the user-set matrix correction function on/off.
		MATRIX (PRESET)	OFF/ON	ON	Turns the preset matrix correction function on/off.
		MATRIX R-G	(-99 to +99)	0	Sets the arbitrary R-G user-set matrix coefficients.
		MATRIX R-B	(-99 to +99)	0	Sets the arbitrary R-B user-set matrix coefficients.
		MATRIX G-R	(-99 to +99)	0	Sets the arbitrary G-R user-set matrix coefficients.
		MATRIX G-B	(-99 to +99)	0	Sets the arbitrary G-B user-set matrix coefficients.
		MATRIX B-R	(-99 to +99)	0	Sets the arbitrary B-R user-set matrix coefficients.
		MATRIX B-G	(-99 to +99)	0	Sets the arbitrary B-G user-set matrix coefficients.
P12	MTX MULTI	MATRIX	OFF/ON	ON	Turns the linear matrix correction and multi matrix correction functions on/off.
		MATRIX (MULTI)	OFF/ON	OFF	Turns the multi matrix correction function on/off.
		MATRIX AREA IND	OFF/ON	OFF	Turns the zebra indication on/off in the area corresponding to the currently selected setting.
		MATRIX COLOR DET	Moves to color detection page.	EXEC	Detects color.
		MTX (MULTI) AXIS	B/B+/MG-/MG/MG+/R/R+/YL-/YL/YL+/G-/G/G+/CY/CY+/B-	B	Selects the axis for which the multi matrix correction function can be changed.
		MTX (MULTI) HUE	(-99 to +99)	0	Adjusts the color phase affected by the multi matrix correction function in every sixteen-axis mode.
		MTX (MULTI) SAT	(-99 to +99)	0	Adjusts the saturation level affected by the multi matrix correction function in every sixteen-axis mode.
P13	V MODULATION	V MOD	OFF/ON	ON	Turns the V modulation function on/off.
		MASTER VMOD	(-99 to +99)	0	Turns the master V modulation function on/off.
		R VMOD	(-99 to +99)	0	Turns the R V modulation function on/off.
		G VMOD	(-99 to +99)	0	Turns the G V modulation function on/off.
		B VMOD	(-99 to +99)	0	Turns the B V modulation function on/off.
		TEST OUT SELECT	ENC/R/G/B	ENC	Selects the output signal of TEST OUT.

No.	Page	Item	Settings	Default	Description
P14	LOW KEY SAT.	LOW KEY SAT	OFF/ON	OFF	Turns the low key saturation function on/off.
		L.KEY SAT LEVEL	(-99 to +99)	0	Sets the saturation level of the low luminance part.
		L.KEY SAT RANGE	LOW/L.MID/ H.MID/HIGH	HIGH	Sets the luminance level at which the low key saturation function becomes effective.
		Y BLACK GAMMA	OFF/ON	OFF	Turns the Y black gamma function on/off.
		Y BLK GAM LEVEL	(-99 to +99)	0	Sets the gamma curve in the low luminance part.
		Y BLK GAM RANGE	LOW/L.MID/ H.MID/HIGH	HIGH	Sets the luminance level at which the Y black gamma becomes effective.
P15	SCENE FILE	1	—	—	Recalls the scene file saved in the memory of the camcorder.
		2	—	—	
		3	—	—	
		4	—	—	
		5	—	—	
		STANDARD	—	—	Clears all current detail-adjusted settings and switch settings and returns the settings to the standard settings saved in the reference file.
		SCENE RECALL	—	—	Recalls the scene file from the memory of the camcorder or the "Memory Stick."
		SCENE STORE	—	—	Stores the scene file in the memory of the camcorder or the "Memory Stick."
		F.ID	16 characters	—	Sets the File ID.



MAINTENANCE Menu

The following table lists and describes the items in the MAINTENANCE menu.

When the setting range in the Settings column is surrounded by parentheses (), the setup value is a relative value. The setting range shown on the menu screen may differ from what is shown in the manual.

No.	Page	Item	Settings	Default	Description
M01	WHT SHADING	WHT SHAD CH SEL	R/G/B/TEST	R	Selects the channel adjusted by this menu. If TEST is selected, the setting is the same as the setting of TEST OUT SELECT.
		TEST OUT SELECT	ENC/R/G/B	ENC	Selects the signal output to the TEST OUT connector.
		R/G/B WHT H SAW	(-99 to +99)	0	Adjusts the H Saw white shading compensation.
		R/G/B WHT H PARA	(-99 to +99)	0	Adjusts the H Parabola white shading compensation.
		R/G/B WHT V SAW	(-99 to +99)	0	Adjusts the V Saw white shading compensation.
		R/G/B WHT V PARA	(-99 to +99)	0	Adjusts the V Parabola white shading compensation.
		WHITE SAW/PARA	OFF/ON	ON	Turns white shading Saw and Parabola compensation on and off.
M02	BLK SHADING	BLK SHAD CH SEL	R/G/B/TEST	R	Selects the channel adjusted by this menu. If TEST is selected, the setting is the same as the setting of TEST OUT SELECT.
		TEST OUT SELECT	ENC/R/G/B	ENC	Selects the signal output to the TEST OUT connector.
		R/G/B BLK H SAW	(-99 to +99)	0	For the H Saw black shading compensation
		R/G/B BLK H PARA	(-99 to +99)	0	For the H Parabola black shading compensation
		R/G/B BLK V SAW	(-99 to +99)	0	For the V Saw black shading compensation
		R/G/B BLK V PARA	(-99 to +99)	0	For the V Parabola black shading compensation
		BLACK SAW/PARA	OFF/ON	ON	Turns black shading Saw and Parabola compensation on and off.
		MASTER BLACK	(-99 to +99)	0	Adjusts the master black level.
		MASTER GAIN(TMP)	-3/0/3/6/9/12/18/24/30/36/42/48 dB	0 dB	Temporarily adjusts the master gain value.
M03	LEVEL ADJ	ENC VIDEO LEVEL	(-99 to +99)	0	Adjusts the encoder video level.
		RGB LEVEL	(-99 to +99)	0	Adjusts the R/G/B video level.
		TEST OUT SELECT	ENC/R/G/B	ENC	Selects the signal output to the TEST OUT connector.
		H BLANKING WIDTH	(-99 to +99)	0	Adjusts the H blanking width.

No.	Page	Item	Settings	Default	Description
M04	BATTERY	BEFORE END 1	5/10/15 to 95/100% (in 5% steps)	5%	Used when a Sony-made battery pack, such as BP-GL65/GL95, is used. Set the voltage warning level just before the battery ends.
		END 1	0/1/2/3/4/5%	0%	Used when a Sony-made battery pack, such as BP-GL65/GL95, is used. Set the voltage level at which the battery ends and the camcorder stops operation, just before the battery ends.
		BEFORE END 2	11.0 to 17.0V (in 0.1V steps)	11.3	Used when a Sony-made battery pack, such as BP-L60S, is used. Set the voltage warning level just before the battery ends.
		END 2	10.5 to 11.5 V (in 0.1V steps)	11.0	Used when a Sony-made battery pack, such as BP-L60S, is used. Set the voltage level at which the battery ends and the camcorder stops operation, just before the battery ends.
		BEFORE END 3	11.0 to 17.0 V (in 0.1V steps)	11.8	Used when a battery pack other than a Sony-made one or an external power connected to the DC IN connector is used. Set the voltage warning level just before the battery ends.
		END 3	10.5 to 14.0 V (in 0.1V steps)	11.0	Used when a battery pack other than a Sony-made one or an external power connected to the DC IN connector is used. Set the voltage level at which the battery ends and the camcorder stops operation, just before the battery ends.
		BATT REMAIN DISP	1/2/3	1	1: Standard mode 2: LCD remaining indication mode: One ■ on the LCD indicates 10% for a battery classified in <Others, EXT DC> type. 3: ANTON mode: Remaining detection of the ANTON type is made even for a battery classified in <SONY> type.
M05	AUDIO-1	V/A OUT (FF/REW)	EE/PB	EE	Selects the video output signal during FF/REW. EE: Input signal PB: Playback signal
		REC AUDIO OUT	EE/SAVE	EE	Selects the audio output signal during recording. EE: Input signal SAVE: Not to output
		CA-701 AUDIO IN	ENABL/DSABL	ENABL	When a CA-701 camera adaptor is connected, select whether or not to enable input of audio channels 3 and 4 from the camera adaptor. ENABL: Camera adaptor can be used. DSABL: Camera adaptor cannot be used.
		AUDIO CH3/4 MODE	CH1/2/SW	SW	Selects the sources to be recorded to channels CH-3/4. CH1/2: Same sources as CH-1/2. SW: Signals selected by the AUDIO IN CH-3/CH-4 switches.
		REAR XLR AUTO	OFF/ON	OFF	Turns the XLR connection automatic detection on/off.
		FRONT MIC REF	-60 dB/-50 dB	-60 dB	Sets the reference level of the front microphone.
		REAR 1 MIC REF	-60 dB/-50 dB	-60 dB	Sets the reference level when the AUDIO IN CH1 connector is set to MIC.
		REAR 2 MIC REF	-60 dB/-50 dB	-60 dB	Sets the reference level when the AUDIO IN CH2 connector is set to MIC.

No.	Page	Item	Settings	Default	Description
M06	AUDIO-2	AU DATA LENGTH	16 bit/20 bit	16 bit	Sets the bit length of the digital audio recording.
		AU REC EMPHASIS	OFF/ON	OFF	Turns the emphasis function on/off.
		AU REF LEVEL	-20 dB/-18 dB	-20 dB	Sets the output level of the 1 kHz test signal.
		AU REF OUT	0 dB/+4 dB/-3 dB	0 dB	Sets the output reference level.
M07	AUDIO-3	AU SG (1kHz)	ON/OFF/AUTO	OFF	Sets whether to output a 1 kHz test tone during the Color Bar mode or not. ON: a 1 kHz test tone is output during the Color Bar mode. OFF: a 1 kHz test tone is not output during the Color Bar mode. AUTO: a 1 kHz test tone is output only when the CH 1 AUDIO SELECT switch on the inside panel is in the AUTO position.
		MIC CH1 LEVEL	SIDE1/FRONT/ F+S1	FRONT	When recording the front microphone sound on CH 1, select which control is to be used for the level adjustment. SIDE 1: Adjust it with the LEVEL control (left side) on the side panel. FRONT: Adjust it with the MIC LEVEL control on the front panel. F + S1: It can be adjusted using either the LEVEL control (left side) or the MIC LEVEL control. (The two controls are linked to each other.)
		MIC CH2 LEVEL	SIDE2/FRONT/ F+S2	FRONT	When recording the front microphone sound on CH 2, select which control is to be used for the level adjustment. SIDE 2: Adjust it with the LEVEL control (right side) on the side panel. FRONT: Adjust it with the MIC LEVEL control on the front panel. F + S2: It can be adjusted using either the LEVEL control (right side) or the MIC LEVEL control. (The two controls are linked to each other.)
		REAR1/WRR LEVEL	SIDE1/FRONT/ F+S1	SIDE 1	Selects any of these controls to adjust the audio level of the equipment that is connected to the wireless microphone and whatever is connected to the AUDIO IN CH1 connector on the rear panel. SIDE 1: Adjust it with the LEVEL control (left side) on the side panel. FRONT: Adjust it with the MIC LEVEL control on the front panel. F + S1: It can be adjusted using either the LEVEL control (left side) or the MIC LEVEL control. (The two controls are linked to each other.)
		REAR2/WRR LEVEL	SIDE2/FRONT/ F+S2	SIDE 2	Selects any of these controls to adjust the audio level of the equipment that is connected to the wireless microphone and whatever is connected to the AUDIO IN CH2 connector on the rear panel. SIDE 2: Adjust it with the LEVEL control (right side) on the side panel. FRONT: Adjust it with the MIC LEVEL control on the front panel. F + S2: It can be adjusted using either the LEVEL control (right side) or the MIC LEVEL control. (The two controls are linked to each other.)

No.	Page	Item	Settings	Default	Description
M08	TIMECODE	TC OUT	AUTO/GENE	AUTO	Selects the time code signal output. AUTO: Outputs the time code generator output during recording and outputs the time code reader output during playback. GENE: Outputs the time code generator output during recording and playback.
		DF/NDF (MSW-970 only)	DF/NDF	DF	Sets DF or NDF mode. DF: Drop frame mode NDF: Non-drop frame mode
		EXT-LK UBIT	INT/EXT	INT	Sets whether the LTC UBIT setup value locks to an INT or an EXT source when the time code is locked to an external source. INT: Internal lock EXT: External lock
		LTC UBIT	FIX/TIME	FIX	Sets the data to be recorded in UBIT of LTC. FIX: Records the data that is set by the user. TIME: Records the present time.
		VITC UBIT	FIX/TIME	FIX	Sets the data to be recorded in UBIT of VITC. FIX: Records the data that is set by the user. TIME: Records the present time.
		WATCH AUTO ADJ	OFF/ON	ON	Turns the automatic time correction function of the built-in clock on/off . With ON, the time of the built-in clock matches with the time data of the user bits of an external time code.
		UBIT GROUP ID	000/101	000	Selects the UBIT GROUP ID.
		VITC INS LINE 1	12 to 19 H (MSW-970)	16H	Selects the line into which VITC is to be inserted.
			9 to 22 H (MSW-970P)	19H	
		VITC INS LINE 2	12 to 19 H (MSW-970)	18H	Selects the line into which VITC is to be inserted.
9 to 22 H (MSW-970P)	21H				
M09	VTR MODE	REC TALLY BLINK	OFF/ON	ON	Turns the tally illumination control on/off in the event of BATTERY BEFORE END/DISC BEFORE END.
		REC START BEEP	OFF/ON	OFF	Turns on/off the alarm sound at REC START/ STOP.
		LCD DISPLAY HOLD	TIMER/OFF/CONT	TIMER	Sets the time code (TC) display after power-off as follows. TIMER: The TC display turns off after the elapse of the time set by the LCD HOLD TIMER below. OFF: Not displayed. CONT: Displayed.
		LCD HOLD TIMER	1H/3H/8H	1H	Sets the duration of time after which the TC display is to be turned off after power-off, when LCD DISPLAY HOLD is set to TIMER (H: hours).
		REC VIDEO RATE	50M/40M/30M	50M	Sets the recording bit rate.
		STBY OFF TIMER	OFF/5MIN/10MIN/30MIN/60MIN	60MIN	Sets the length of time for the stand-by off timer.
		STOP KEY FREEZE	OFF/FIELD/	OFF	Selects the freeze function.

No.	Page	Item	Settings	Default	Description
M10	ESSENCE MARK	LTC UB-MARKER	SET/ALL/OFF	SET	Sets whether to write the markers in UBIT of LTC or not. SET: To independently select the ON/OFF setting of the following items, REC START MARK, SHOT MARK 1, and SHOT MARK 2 ALL: To write REC START MARK, SHOT MARK 1, and SHOT MARK 2 all. OFF: None are written.
		REC START MARK	OFF/ON	OFF	Turns REC START MARK on/off.
		SHOT MARK 1	OFF/ON	OFF	Turns SHOT MARK 1 on/off.
		SHOT MARK 2	OFF/ON	OFF	Turns SHOT MARK 2 on/off.
		SHOT TIME DISP	MD:HM/DM:HM/D:HMS	MD:HM	Selects the format of the time to be displayed on the LCD. MD:HM: Month, day, hour, minute DM:HM: Day, month, hour, minute D:HMS: Day, hour, minute, second
M11	ESSENCE MARK2	OVER AUDIO LIMIT	OFF/ON	ON	Turns the function to write a mark when the audio level exceeds 0 dB in recording on/off.
		GAIN CHG MARK	OFF/ON	ON	Turns the function to write a mark when the gain is changed in recording on/off.
		FILTER CHG MARK	OFF/ON	ON	Turns the function to write a mark when the ND filter or CC filter is changed in recording on/off.
		SHUTTER CHG MARK	OFF/ON	ON	Turns the function to write a mark when the shutter speed or shutter mode is changed in recording on/off.
		WHITE CHG MARK	OFF/ON	ON	Turns the function to write a mark when the white balance is changed in recording on/off.
		FLASH MARK	OFF/ON	ON	Turns the function to write a mark when an extreme luminance change occurs in recording on/off.
		FLASH MARK LEVEL	1 to 20	10	Sets the threshold of the luminance change to permit a mark to be written for FLASH MARK.
		E. MARK SD LINE	12/13/15/16/17/18/19 (MSW-970) 9/10/12/13/14/15/16/17/18 (MSW-970P)	17 14	Specifies the essence mark output SDI VANC LINE number to be recorded on the tape.
M12	PRESET WHT	COLOR TEMP <P>	Display color temperature.	3200	White balance preset value
		COLOR FINE <P>	(-99 to +99)	0	—
		R GAIN <P>	(-99 to +99)	0	R gain preset value
		B GAIN <P>	(-99 to +99)	0	B gain preset value
		D5600K <P>	OFF/ON	OFF	Turns the electric 5600K filter on/off.
		AWB ENABLE <P>	OFF/ON	OFF	Turns the function which automatically acquires the preset value for automatic white balance adjustment on/off.

No.	Page	Item	Settings	Default	Description
M13	DCC ADJUST	DCC FUNCTION SEL	DCC/ADP.K/FIX	DCC	Selects the function assigned to the DCC switch. ADP.K is Adaptive knee and FIX is fixed knee.
		DCC D RANGE	400/450/500/550/600%	600%	Sets the timing range when the DCC switch is set to the ON position.
		DCC POINT	(-99 to +99)	0	For the DCC minimum knee point adjustment
		DCC GAIN	(-99 to +99)	0	For the gain adjustment to DCC detected value
		DCC DELAY TIME	(-99 to +99)	0	Adjusts the DCC reaction speed.
M14	AUTO IRIS 2	IRIS WINDOW	1/2/3/4/5/6/VAR	1	Selects the auto iris detection window. VAR is variable.
		IRIS WINDOW IND	OFF/ON	OFF	Turns on and off the function which displays a frame marker for the auto iris detection window.
		IRIS LEVEL	(-99 to +99)	0	Adjusts the level of the auto iris target value
		IRIS APL RATIO	(-99 to +99)	0	Adjusts the mix ratio of auto iris detection peak value and average value.
		IRIS VAR WIDTH	20 to 465	245	Sets the width and height of detection frame when the auto iris detection window is set to VAR.
		IRIS VAR HEIGHT	17 to 120 (MSW-970)	72	Sets the height of detection frame when the auto iris detection window is set to VAR.
			20 to 142 (MSW-970P)	85	
		IRIS VAR H POS.	-447 to +446	0	Sets the horizontal position of detection frame when the auto iris detection window is set to VAR.
		IRIS VAR V POS.	-104 to +104 (MSW-970)	0	Sets the vertical position of detection frame when the auto iris detection window is set to VAR.
			-124 to +123 (MSW-970P)	0	
		IRIS SPEED	(-99 to +99)	0	Adjusts the auto iris operation speed.
CLIP HIGH LIGHT	OFF/ON	OFF	Turns on and off the function which, during auto iris adjustment, ignores very bright areas by dulling the reaction to high luminescence.		

No.	Page	Item	Settings	Default	Description
M15	FUNCTION 3	WHT FILTER INH	OFF/ON	OFF	Turns on and off the function which inhibits independent white memory for each filter position.
		COLOR BAR SEL	SMPTE/EBU/SNG	SMPTE (MSW-970)	Selects the color bar type.
				EBU (MSW-970P)	
		REC TALLY	UPPER/BOTH	UPPER	Selects whether to light the upper tally indicator only, or both upper and lower tally indicators.
		COLOR VF INPUT	COMP/VBS/BOTH	COMP	For video input selection when a color viewfinder is used
		USER & ALL ONLY	OFF/ON	OFF	Selects whether to show only USER, USER MENU CUSTOMIZE, and ALL menus in the top menu.
		RM COMMON MEMORY	OFF/ON	OFF	Selects whether or not to share settings for when an RM remote control unit is connected and when the unit is used alone.
		RM REC START	RM/CAM/PARA	RM	Selects which VTR START/STOP buttons (on the RM, camera, or both) are enabled when an RM-series remote control unit is connected.
		REC INH. WITH CCU	OFF/ON	ON	Selects whether to disable recording operations when a CCU is connected. A large viewfinder cannot be used with the OFF setting.
EXT VTR REC CTL	OFF/ON	OFF	Selects whether to synchronize recording with an external VTR via a CCZ cable when the CA-702 is connected.		
M16	FUNCTION 4	SET DISP MODE	SEC/DEG	SEC	Selects whether to display the shutter speed in seconds or degrees.
		AWB FIXED AREA	OFF/ON	OFF	Selects whether or not to perform AWB for all pixels in the rectangular area of 25% by 25%.
M17	GENLOCK	GENLOCK	OFF/ON	ON	Turns genlock on and off.
		RETURN VIDEO	OFF/ON	OFF	Turns return video on and off.
		GL H PHASE	(-99 to +99)	0	Adjusts the genlock H phase.
		GL SC PHASE	(-99 to +99)	0	Adjusts the genlock subcarrier phase.
		GL SC 0/180 SEL	0/180	180	For coarse adjustment of the genlock subcarrier phase.
M18	ND COMP	ND OFFSET ADJUST	OFF/ON	—	Turns on and off the mode which sets ND (neutral density) filter color compensation values.
		CLEAR ND OFFSET	—	EXEC	Clears ND filter color compensation values.
M19	AUTO SHADING	AUTO BLK SHADING	EXEC	EXEC	Executes the auto black shooting function.
		RESET BLK SHD	EXEC	EXEC	Clears black shooting compensation values.
		TEST OUT SELECT	ENC/R/G/B	ENC	Selects the signal output to the TEST OUT connector.
		MASTER GAIN (TMP)	-3/0/3/6/9/12/18/24/30/36/42/48 dB	0 dB	Temporarily sets the master gain value.

No.	Page	Item	Settings	Default	Description
M20	VANC RX	UMID LINE	0, 12, 13, 15 to 19 (MSW-970)	0	Selects the line on which the UMID is to be recorded.
			0, 9, 10, 12 to 18 (MSW-970P)		

FILE Menu

The following table lists and describes the items in the FILE menu.

When the setting range in the Settings column is surrounded by parentheses (), the setup value is a relative

value. The setting range shown on the menu screen may differ from what is shown in the manual.

No.	Page	Item	Settings	Default	Description
F01	USER FILE	USER FILE LOAD	—	EXEC	See "6-1 Saving and Loading User Files" on page 105.
		USER FILE SAVE	—	EXEC	
		F. ID	16 characters	—	
		USER PRESET	—	EXEC	See "5-4 Resetting USER Menu Settings to the Standard Settings" on page 104.
F02	USER FILE2	STORE USR PRESET	—	EXEC	Sets the pages registered in the USER menu to the standard setting.
		CLEAR USR PRESET	—	EXEC	Clears the standard setting of pages registered in the USER menu.
		CUSTOMIZE RESET	—	EXEC	Returns the setting of the pages registered in the USER menu to the factory default state.
		LOAD CUSTOM DATA	OFF/ON	OFF	Selects whether to read the USER MENU CUSTOMIZE settings to be loaded by USER FILE LOAD.
		LOAD OUT OF USER	OFF/ON	OFF	Selects whether to read pages not registered by USER FILE LOAD.
		BEFORE FILE PAGE	OFF/ON	OFF	Selects whether to read data after USER FILE pages by USER FILE LOAD.
		USER LOAD WHITE	OFF/ON	OFF	Selects whether to read white balance data by USER FILE LOAD.
F03	ALL FILE	ALL FILE LOAD	—	EXEC	Loads ALL file.
		ALL FILE SAVE	—	EXEC	Saves ALL file.
		F. ID	16 characters	—	To name ALL file.
		ALL PRESET	—	EXEC	Returns items in the ALL file to preset values.
		STORE ALL PRESET	—	EXEC	Sets the preset values of items in the ALL file.
		CLEAR ALL PRESET	—	EXEC	Clears the preset values of items in the ALL file.
		3SEC CLR PRESET	OFF/ON	OFF	Turns on and off the function to clear the standard setting when the MENU knob is kept pressed for 3 seconds.
F04	SCENE FILE	1	—	—	See "6-2 Saving and Loading Scene Files" on page 109.
		2	—	—	
		3	—	—	
		4	—	—	
		5	—	—	
		STANDARD	—	—	
		SCENE RECALL	—	EXEC	
		SCENE STORE	—	EXEC	
		F. ID	16 characters	—	

No.	Page	Item	Settings	Default	Description
F05	REFERENCE	REFERENCE STORE	—	EXEC	Saves the reference file in internal memory.
		REFERENCE CLEAR	—	EXEC	Clears the reference file.
		REFERENCE LOAD	—	EXEC	Loads the reference file.
		REFERENCE SAVE	—	EXEC	Saves the reference file to "Memory Stick."
		F. ID	16 characters	—	To name the reference file.
		SCENE WHITE DATA	OFF/ON	OFF	See "White balance setting data to be saved in the scene file" on page 110.
F06	LENS FILE 1	LENS FILE RECALL	—	EXEC	Loads lens files.
		LENS FILE STORE	—	EXEC	Saves lens files.
		F. ID	16 characters	—	To name lens files.
		LENS NO OFFSET	—	EXEC	To clear lens files.
		SOURCE MEMORY	—	MEMORY1	Number of selected lens file
		IRIS GAIN	(-99 to +99)	0	Iris gain value of lens file
		LENS AUTO RECALL	OFF/ON	ON	Turns the automatic recall function for serial lens.
		L. ID	(Display only)	—	To show the lens-specific ID (when a serial lens is connected).
		L. MF	(Display only)	—	To show the name of the lens manufacturer (when a serial lens is connected).
F07	LENS FILE 2	LENS M VMOD	(-99 to +99)	0	For the lens file V Saw shading
		LENS CENTER H	-48 to +47	0	For the horizontal position compensation of lens file center marker
		LENS CENTER V	-15 to +14	0	For the vertical position compensation of lens file center marker
		TEST OUT SELECT	ENC/R/G/B	ENC	Selects signal output to TEST OUT connector.
		LENS R FLARE	(-99 to +99)	0	Adjusts the lens file flare (R).
		LENS G FLARE	(-99 to +99)	0	Adjusts the lens file flare (G).
		LENS B FLARE	(-99 to +99)	0	Adjusts the lens file flare (B).
		LENS W-R OFST	(-99 to +99)	0	Adjusts the R compensation value for white.
		LENS W-B OFST	(-99 to +99)	0	Adjusts the B compensation value for white.
F08	LENS FILE 3	SHADING CH SEL	R/G/B/TEST	R	Selects the channel adjusted by this menu. If TEST is selected, the setting is the same as the setting of TEST OUT SELECT.
		TEST OUT SELECT	ENC/R/G/B	ENC	Selects the signal output to the TEST OUT connector.
		LENS R/G/B H SAW	(-99 to +99)	0	For the H Saw white shading compensation
		LENS R/G/B H PARA	(-99 to +99)	0	For the H Parabola white shading compensation
		LENS R/G/B V SAW	(-99 to +99)	0	For the V Saw white shading compensation
		LENS R/G/B V PARA	(-99 to +99)	0	For the V Parabola white shading compensation
F09	MEMORY STICK	M.S. FORMAT	—	EXEC	Formats a "Memory Stick."
		M.S. IN > JUMP TO	OFF/USER/ ALL/SCENE/ LENS/REFER/ USER1	OFF	See "6-3 Jumping to a File-Related Menu Page When Inserting a "Memory Stick" on page 113.

No.	Page	Item	Settings	Default	Description
F10	TELE FILE	TELE FILE CLEAR	—	EXEC	<i>See "3-4 Tele-File System" on page 53.</i>
		TELE FILE MARK	OK/NG/KP	OK	
		ID			
		SIZE			
		REMAIN			
		STATUS			

DIAGNOSIS Menu

The following table lists and describes the items in the DIAGNOSIS menu.

No.	Page	Item	Description
D01	HOURS METER	RESET METER	Resets the resettable meters (-2).
		DRUM RUNNING	Displays the total time the drum has rotated.
		TAPE RUNNING	Displays the accumulated time the tape has run.
		OPERATION	Display the time that the unit has been powered.
		THREADING	Displays the number of time of tape threading.
		DRUM RUNNING-2	Displays the total time the drum has rotated (reset possible).
		TAPE RUNNING-2	Displays the accumulated time the tape has run (reset possible).
		OPERATION-2	Display the time that the unit has been powered (reset possible).
		THREADING-2	Displays the number of time of tape threading (reset possible).
D02	TIME/DATE	ADJUST	<i>See "5-3-6 Setting the Date/Time of the Internal Clock" on page 97.</i>
		HOUR	
		MIN	
		SEC	
		YEAR	
		MONTH	
		DAY	
D03	ROM VERSION	AT: Ver. X.XX	Displays ROM version.
		SS: Ver. X.XX	
		FP: Ver X.XX	
		EQ: Ver X.XX	
D04	DEV STATUS	I/O EEPROM LSI FRAM SCI	Displays the self diagnosis.
D05	OPTION BOARD	SDI OUTPUT	Displays installed options.
		COMPOSITE VIDEO INPUT	
		PULL DOWN (24P) ¹⁾	
		PICTURE CACHE	

1) MSW-970 only

About a “Memory Stick”

What is “Memory Stick”?

“Memory Stick” is a new compact, portable and versatile IC (Integrated Circuit) recording medium with a data capacity that exceeds a floppy disk. “Memory Stick” is specially designed for exchanging and sharing digital data among “Memory Stick” compatible products. Because it is removable, “Memory Stick” can also be used for external data storage.

“Memory Stick” is available in two sizes: standard size and compact “Memory Stick Duo” size. Once attached to a “Memory Stick Duo” adapter, “Memory Stick Duo” turns to the same size as standard “Memory Stick” and thus can be used with products compliant with standard “Memory Stick”.

Types of “Memory Stick”

“Memory Stick” is available in the following four types to meet various requirements in functions.

“Memory Stick-R”

Stored data are not overwritten. You can write data to “Memory Stick-R” with “Memory Stick-R” compatible products only. Copyright protected data that requires MagicGate copyright protection technology cannot be written to “Memory Stick-R.”

“Memory Stick”

Stores any type of data except copyright-protected data that requires the MagicGate copyright protection technology.

“MagicGate Memory Stick”

Equipped with the MagicGate copyright protection technology.

“Memory Stick-ROM”

Stores pre-recorded, read-only data. You cannot record on “Memory Stick-ROM” or erase the pre-recorded data.

Available types of “Memory Stick”

You can use a “Memory Stick” or a “MagicGate Memory Stick” with your product.

Note

You can not use a “Memory Stick Duo” with your product.

Note on data read/write speed

Data read/write speed may vary depending on the combination of the “Memory Stick” and “Memory Stick” compliant product you use.

What is MagicGate ?

MagicGate is copyright protection technology that uses encryption technology.

Before using a “Memory Stick”

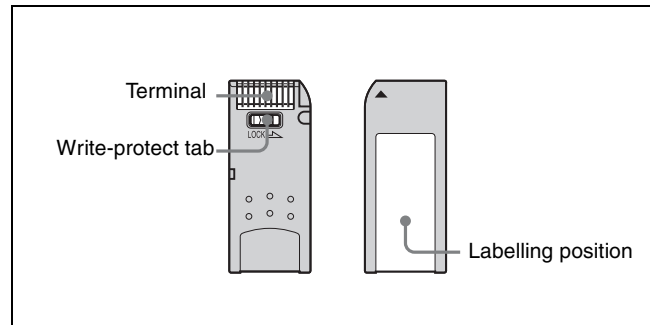

- When you set the “Memory Stick” erasure prevention switch to “LOCK,” data cannot be recorded, edited, or erased.
- Data may be damaged if:
 - You remove the “Memory Stick” or turn off the unit while it is reading or writing data.
 - You use the “Memory Stick” in a location subject to the effects of static electricity or electric noise.
- We recommend that you make a backup copy of important data that you record on the “Memory Stick”.

Notes

- Do not attach anything other than the supplied label to the “Memory Stick” labeling position.
- Attach the label so that it does not stick out beyond the labeling position.
- Carry and store the “Memory Stick” in its case.
- Do not touch the connector of the “Memory Stick” with anything, including your finger or metallic objects.
- Do not strike, bend, or drop the “Memory Stick”.
- Do not disassemble or modify the “Memory Stick”.
- Do not allow the “Memory Stick” to get wet.
- Do not use or store the “Memory Stick” in a location that is:
 - Extremely hot, such as in a car parked in the sun
 - Under direct sunlight
 - Very humid or subject to corrosive substances

ACCESS Indicator

If the access indicator is turned on or is flashing, data is being read from or written to the “Memory Stick”. At this time, do not shake the computer or product or subject them to shock. Do not turn off the power of the computer and product or remove the “Memory Stick”. This may damage the data.

Precautions

- To prevent data loss, make backups of data frequently. In no event will Sony be liable for any loss of data.
- Unauthorized recording may be contrary to the provisions of copyright law. When you use a “Memory Stick” that has been pre-recorded, be sure that the material has been recorded in accordance with copyright and other applicable laws.
- The “Memory Stick” application software may be modified or changed by Sony without prior notice.
- Note that there are certain restrictions on recording stage performances and other entertainment events, even if they are recorded for personal use only.

- “Memory Stick”,  and “MagicGate Memory Stick” are trademarks of Sony Corporation.
- “Memory Stick Duo” and **MEMORY STICK DUO** are trademarks of Sony Corporation.
- “Memory Stick PRO” and **MEMORY STICK PRO** are trademarks of Sony Corporation.
- “MagicGate” and **MAGICGATE** are trademarks of Sony Corporation.

Index

Symbols

"LED 142

Numerics

24P mode 100

A

ABNORMAL window 89
AC adaptor 116
AC-550/550CE 116
ACCESS indicator 26
Accessory Attachments 17
accidental erasure 35
AC-DN10 116
actual time in the time code 72
ADVANCE button 29
ALARM volume control 19
Aliasing 135
ALL FILE 159
ALL menu 75
analog composite video signals 55
Anton Bauer Ultralight System 116
aspect ratio 98
ASSIGN 1/2 switches 23
ASSIGN SEL window 95
Assignable Switches 95
ATW 63, 141
Audio channel level meter 31
Audio Functions 18
AUDIO IN CH1/CH2 connectors 20
AUDIO IN CH-1/CH-2/CH-3/CH-4
switches 20
audio level 69
AUDIO OUT connector 20
AUDIOSELECTCH-1/CH-2 switches
19
AUDIO STATUS window 90
AUDIO-1 152
AUDIO-2 153
AUDIO-3 153
Auto Interval Rec mode 44
AUTO IRIS 143
AUTO IRIS 2 156
AUTO IRIS page 67
AUTO SHADING 157
Auto Tracing White 63, 141
AUTO W/B BAL switch 23
automatic black balance adjustment 60
automatic iris adjustment 67
automatic iris window 68

automatic white balance adjustment
61

B

BACK TALLY indicator 30
BACK TALLY switch 30
BATT indicator 33
BATTERY 152
Battery attachment 16
battery pack 115
Battery status indicator 31
BKW-401 118
black balance 60
BLACK GAMMA 147
BLACK/FLARE 146
BLK SHADING 151
BP-GL65/GL95/L60S 115
BRIGHT control 21
Built-in speaker 19

C

Camera operator tally indicator 22
CANCEL/PRST / ESCAPE switch 27
cassette
loading 34
unloading 35
CBK-SD01 52
CC filter 61
CCD image sensors 135
CH-1/2 / CH-3/4 switch 18
Cleaning
video heads 133
viewfinder 133
color temperature 93
Condensation 129
continues recording 37
Continuous Trigger mode 47
CONTRAST control 21

D

DATA DISPLAY switch 29
Date/Time of the Internal Clock 97
DC IN connector 16
DC OUT 12 V connector 20
DCC ADJUST 156
DETAIL 1 147
DETAIL 2 148
DETAIL 3 148
DEV STATUS 162
DIAGNOSIS menu 76
diopter adjustment 117
Diopter adjustment ring 22
display mode 85
Display panel 31
DISPLAY switch 29, 30
drop frame mode 72

E

EARPHONE jacks 18
ECS (Extended Clear Scan) mode 63
EJECT button 25
Eject button 26
End Search function 51
error messages 135
ESSENCE MARK 155
ESSENCE MARK page 39, 40
ESSENCE MARK2 155
ESSENCE MARK2 page 39
essence marks 38
EVS (Enhanced Vertical definition
System) mode 64
external microphone 121
Eyepiece 118
disassembling 133

F

F FWD button and indicator 25
FILE menu 76
FILTER selector 22
flange focal length 120
Fog-proof filter 133
FORMAT 144
FORMAT page 98
freeze-frame mode 58
F-RUN/SET/R-RUN switch 29
FUNCTION 157
FUNCTION 1 140
FUNCTION 1 page 95
FUNCTION 2 141
FUNCTION 3 157
FUNCTION 4 157
FUNCTION window 90

G

Gain 92
GAIN selector 23
GAIN SW 142
GAIN SW page 92
GAMMA 147
GENLOCK 157
GENLOCK IN connector 28
GENLOCK page 91
good shot marks 38, 41

H

HOLD button 29
HOURS METER 162

I

I mode 99
Interlace scan mode 99

Interval Rec Function 43

K

KNEE 147

L

Lens

mounting 119

LENS connector 17

LENS FILE 144

lens file 98

LENS FILE 1 160

LENS FILE 2 160

LENS FILE 3 160

LENS FILE page 98

Lens locking lever 17

Lens mount 17

Lens mount cap 17

LEVEL (CH-1/CH-2) controls 19

LEVEL ADJ 151

LIGHT connector 17

Light shoe 17

LIGHT switch 16, 30

LINE/MIC/+48 V ON switches 20

LOCK knob 22

LOW KEY SAT. 150

M

MAINTENANCE menu 76

Manual Interval Rec mode 47

MARKER 1 142

MARKER 1 page 86

MARKER 2 142

Marker Display 86

Memory Label 53

MEMORY STICK 160

Memory Stick compartment 26

MEMORY STICK OPEN button 26

MEMORY STICK page 113

MENU knob 26

MENU ON/OFF switch 26

Menu Organization 75

MIC IN connector 18

MIC LEVEL control 18

Microphone 18

MONITOR switch 18

MONITOR volume control 19

MSDW-904 55

MTX LINEAR 149

MTX MULTI 149

N

ND COMP 157

ND filter 61

non-drop frame mode 72

O

OFFSET WHT 143

OFFSET WHT page 94

OPERATION menu 75

operation messages 135

Operation warnings 134

OPTION BOARD 162

OUTPUT SEL 139

OUTPUT SEL page 93

Output Signals 93

OUTPUT/DCC selector 23

P

PAINT menu 76

PEAKING control 21

Picture Cache Function 41

Picture Cache mode 41

Picture Cache time 41

PLAY button and indicator 25

Playback in Color 52

Power Supply 16

POWER switch 16

PRESET WHT 155

PRESET/REGEN/CLOCK switch 29

Progressive scan mode 99

PsF mode 99

Pull down mode 100

R

Rain Cover 126

REAR TALLY indicator 31

REC indicator 33

Recording Review 52

recording start mark 38, 41

REFERENCE 160

reference file 113

REMOTE connector 24

RESET button 29

RE-TAKE function 50

return video signal 91

REW button and indicator 25

ROM VERSION 162

S

SAVE indicator 33

SCENE FILE 150, 159

scene file 109

loading 111

saving 109

SCENE FILE page 109

SET STATUS 143

SET STATUS page 90

SETUP REMOVE 57

SHIFT button 29

SHOT DISP 143

SHOT DISP page 87

SHOT ID 143

shot ID 88

SHOT ID page 88

shot marks 38

Shoulder pad 17

shoulder pad 126

shoulder strap 125

Shoulder strap posts 17

SHT ENABLE 144

SHT ENABLE page 66

SHUTTER selector 23

Single Trigger mode 47

SKIN DETAIL 148

SLS (slow speed shutter) mode 63

SOURCE SEL 144

SOURCE SEL page 56

Spare indicator 33

Stand-by off Timer 59

Status Confirmation Windows 89

STATUS ON/SEL / OFF switch 26

STOP button 25

Supplied accessories 136

supplied microphone 120

SW STATUS 146

System configuration 14

T

TALLY indicator 21, 30, 33

TALLY switch 21, 30

Tape status indicator 31

TC IN connector 28

TC OUT connector 28

TELE FILE 161

TELE FILE page 53

Tele-File Mark 54

TEST OUT 139

TEST OUT connector 24

Time code display 32

time code setting 71

time code synchronization 73

TIME/DATE 162

TIME/DATE page 97

TIMECODE 154

TOP menu 75

tripod 124

tripod adaptor 124

Tripod mount 17

TURBO GAIN button 24

TURBO SW SEL window 96

U

UHF portable tuners 122

UMID SET 145

UMID SET page 102

user bits 72

USER FILE 159
User File 106
USER FILE2 159
USER menu 75
USER MENU CUSTOMIZE menu 75

V

V MODULATION 149
VANC RX 158
Vertical smear 135
VF DISP 1 141
VF DISP 1 page 84
VF DISP 2 141
VF DISP 2 page 85
VF SETTING 142
VF SETTING page 87
VIDEO OUT connector 24
Viewfinder 22
 detaching 118
Viewfinder front-rear positioning lever
 22
Viewfinder left-right positioning ring
 22
viewfinder position 117
Viewfinder Rotation Bracket 118
Viewfinder stopper 22
VTR MODE 154
VTR operation status and status
 indicators 32
VTR SAVE/STBY switch 25
VTR START button 25

W

Warning (!) indicator 33
WARNING indicator 31
WHITE 146
WHITE BAL switch 23
white balance 61
White flecks 135
WHITE page 94
WHT SHADING 151
WRR-855A/855B 122
WRR-860/862 122

X

XLR connection automatic detection
 121, 124

Z

ZEBRA switch 21



The material contained in this manual consists of information that is the property of Sony Corporation and is intended solely for use by the purchasers of the equipment described in this manual.

Sony Corporation expressly prohibits the duplication of any portion of this manual or the use thereof for any purpose other than the operation or maintenance of the equipment described in this manual without the express written permission of Sony Corporation.

Sony Corporation

<http://www.sony.net/>

MSW-970/970P
(SY)
3-863-920-03(1)



Printed on 100% recycled paper.

Printed in Japan
2006.11.13
© 2005