

感谢您购买TILTA产品。

使用本产品之前,请仔细阅读本文以确保已对产品进行正确的设置。本文档及本产品所有相关的文档最终解释权归TILTA所有。如有更新,恕不另行通知。请访问www.tilta.com官方网站以获取最新的产品信息。

一旦使用本产品,即视为您已经仔细阅读免责声明与警告,理解、认可和接受本声明全部条款和内容。您承诺对使用本产品以及可能带来的后果负全部责任。您承诺仅出于正当目的使用本产品,并且同意本条款以及TILTA制定的任何相关条例、政策和指引。

TILTA对于直接或间接使用本产品而造成的损坏、伤害以及任何法律责任不予负责。用户应遵循包括但不限于本文提及的所有安全指引。

即使存在上述规定,消费者权益依然受当地法律法规所保障,并不受本免责声明影响。

TILTA是深圳市铁头科技有限公司及其关联公司的商标。本文出现的产品名称、品牌等,均为其所属公司的商标或注册商标。

（一）滤镜产品使用前的注意事项及免责声明

*【注意事项】：VND 可调ND值为0.3-2.7，建议选择在35mm以上焦段的镜头，24mm等焦段在高档位时会出现十字暗纹或暗角（这是受限于减光镜的原理和构造，无法避免），在购买和使用前请熟知。

*【方形滤镜片注意事项】：关于方形滤镜片的使用请参考说明书第9页【方形滤镜取出注意事项】具体详情，切勿盲目操作。

*【免责声明】：如未根据使用说明操作，拍摄的视频素材出现十字或暗角，使其素材无法使用；或操作不当致其滤镜片损坏，本公司概不负责。

（二）关于滤镜产品维护

光学产品属于精密仪器类产品，运输过程及储存需注意包装保护，置于干燥阴凉处，同时做好防水、防潮保护；因光学产品的清洁需要专业清洁工具和人员，需要注意防尘保护，避免污损后无法清洁。人为损伤包含以下内容：

- ①使用过程中的摔/碰/刮伤。
- ②储存环境不当，导致镜片被腐蚀发霉。
- ③镜片污损，清洁擦拭不当划伤镜片。
- ④运输保护不当，导致损伤。
- ⑤使用后，各接触部位的划痕/露白等问题。
- ⑥更换包装过程/环境不洁净/落尘/采用不正确的清洁方式划伤镜片表面；（落尘后用希尔球吹掉表面灰尘，不能去除的灰尘，可用洁净无尘布蘸取适量97%浓度酒精旋转清洁，避免灰尘的二次划伤）
- ⑦运输途中若需海运，需要对产品进行密封干燥保存，防止海风/海水的高腐蚀对镜片的侵蚀损坏。

以上为几点及不可描述的人为损坏原因，不属于产品的正常维护范围。非人为损坏，产品自身质量问题，我公司负责3个月内的更换和维修。

03 特别提醒

(一)使用幻境遮光斗在高速移动拍摄或极端恶劣的环境下(如沙漠/雪地等), 强烈建议搭配[保护镜]使用, 可有效地保护镜头和滤镜组的使用。

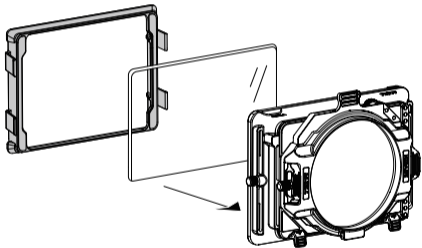

*高速移动拍摄时可不用碳纤维遮扉(MB-T16-TF)。

(二)拆卸斗壳或使用类似拆卸方式的配件时(如幻境软胶消光斗/95mm滤镜叠加配件/4*5.65滤镜卡槽基础配件), 配件与主体的打开角度不宜超过 15° 并且配件向上滑出, 避免对主体安装卡扣造成损坏。

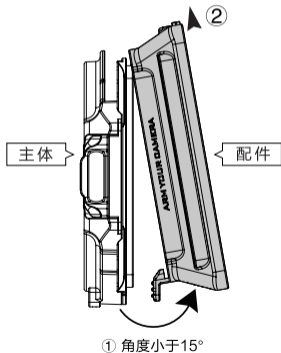

04 认识MIRAGE幻境遮光斗

① 碳纤维遮扉

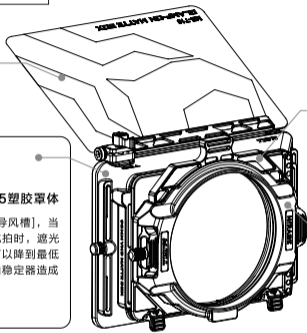

②

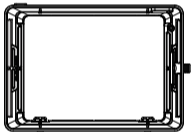

4*5.65 塑胶罩体

前罩体设计了[导风槽]，当在高速车拍及航拍时，遮光罩的风阻影响可以降低到最低，这样不会对三轴稳定器造成更大的压力。

③



95mm 圆形滤镜框
[无配滤镜片]



95mm 可变ND滤镜组
[配带滤镜片，可手动调节ND值]

④

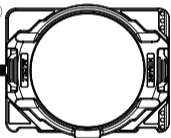

VND 滤镜载体

镁合金材质，超轻量化设计，舒适的抽插手感，便捷的锁紧结构设计，多种扩展功能。

[MIRAGE幻境遮光斗] 是一款为新时代视频创作者开发的全新滤镜系统遮光斗，超级轻量化设计、多形态模块化设计、全新的95mm圆形滤镜框，让用户可以使用成本更低重量更轻的滤镜产品。同时推出一款幻境无线控制VND搭配遮光斗为创作者带来无限的可能，为视频创作者带来更大的价值。

05 分解说明图示

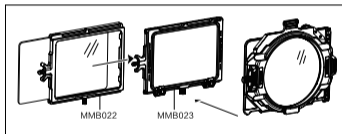
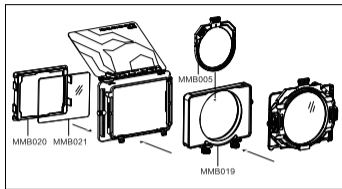
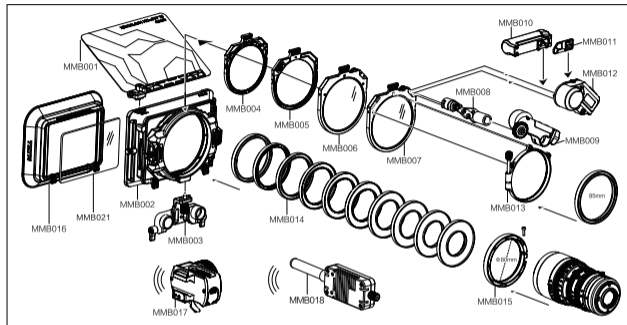

编号	名称	型号
MMB001	碳纤维遮扉	MB-T16-TF
MMB002	VND滤镜载体	-----
MMB003	15mm导轨支撑	MB-T16-LS
MMB004	95mm圆形滤镜框	MB-T16-CFT
MMB005	95mm双面滤镜框	MB-T16-DCF
MMB006	95mmCPL偏振滤镜	MB-T16-POLA

编号	名称	型号
MMB007	95mm可变ND滤镜组	MB-T16-VND
MMB008	原力N电机适配件	MB-TM-NMA
MMB009	原力N马达	WLC-T04-N
MMB010	14500电池仓	MB-TM-PS
MMB011	马达防护盖	-----
MMB012	VND专用马达	MB-TM-WM

编号	名称	型号
MMB013	可变ND轻便型卡圈	MB-T16-LFA
MMB014	86/85/82/77/72/67/62/58/55/52mm镜头接圈	-----
MMB015	80mm无螺纹镜头接圈	MB-T16-C80
MMB016	幻境软胶消光斗	MB-T16-RH
MMB017	幻境无线控制器	MB-TM-WC
MMB018	无线信号放大器	-----

编号	名称	型号
MMB019	95mm滤镜叠加配件	MB-T16-SCF
MMB020	保护镜安装固定配件	MB-T16-FPF
MMB021	保护镜	MB-T16-FPG
MMB022	4*5.65滤镜卡槽叠加配件	MB-T16-SFT
MMB023	4*5.65滤镜卡槽基础配件	MB-T16-SFH

06

产品配置(3个套装)

K1套装



①碳纤维底座



②遮光斗主体



③95mm圆形滤镜框

④82/77/72/67mm
镜头接圈

⑤简易套装包

K2套装



①碳纤维底座



②遮光斗主体



③95mm圆形滤镜框



④95mm可变ND滤镜组

⑤82/77/72/67mm
镜头接圈

⑥15mm导轨支撑



⑦原力N电机及配件



⑧滤镜包



⑨多功能套装包

K3套装



①碳纤维底座



②遮光斗主体



③95mm圆形滤镜框



④95mm可变ND滤镜组

⑤82/77/72/67mm
镜头接圈

⑥15mm导轨支撑



⑦14500电池充电器



⑧滤镜包



⑨多功能套装包



⑩VND专用马达



⑪马达防护盖



⑫14500电池仓



⑬幻境无线控制器



⑭Nato滑条18mm

1. 开箱后将遮光斗安装到镜头

(1) 根据镜头前面的螺纹尺寸选择合适的镜头接圈（套装标配接圈67mm / 72mm / 77mm / 82mm），通过镜头前端螺纹口安装到镜头上，再锁紧遮光斗右边③旋钮把斗卡到镜头前端完成安装。

(2) 如果没有合适的接圈装配，需要单独购买可联系我们有提供更多规格选配。

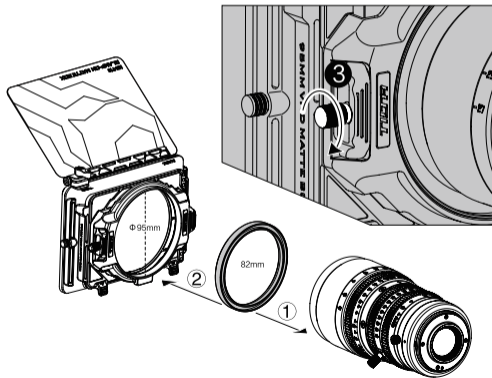

(3) 如果您的镜头是95mm口径，可不需要接圈转接；直接松开遮光斗右边旋钮把斗卡到镜头前端，调整好水平，拧紧②旋钮即可。

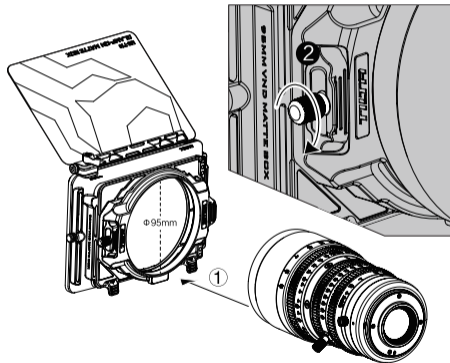

08 K1套装使用说明(二)

2. 碳纤维遮扉的使用

- (1) 遮扉的设计是可以连同卡件整体取下的。
- (2) 在没有炫光情况下，遮扉是可以不需要安装在遮光斗上的，手扭螺丝可以随意调整遮扉的角度以便挡住镜头前的炫光。

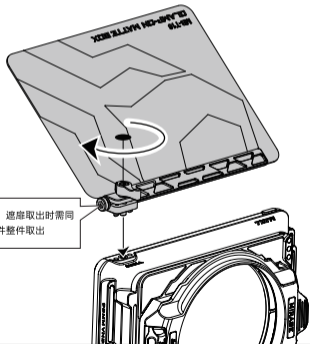

3. 圆形滤镜框(95mm)与圆形滤镜的使用

- (1) K1套装配了一个 $\Phi 95\text{mm}$ 规格的圆形滤镜框，按指示④拨动右边的卡扣，可安装或取出95mm圆形滤镜框⑤。
- (2) 该卡槽可使用各大厂商推出的95mm圆形系列滤镜，包含有ND减光镜，拉丝 / 十字 / 黑柔 / 白柔等各种效果镜片。
- (3) 全新的95mm标准镜片重量是传统4*5.65镜片的1/4，相比圆形螺纹滤镜，圆形滤镜在视频拍摄中将更加高效和实用，非常适合视频创作。

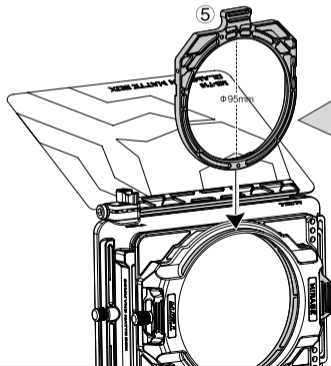

安装95mm滤镜片

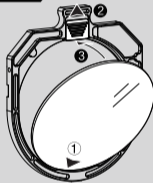

1. 将滤镜片放入底部卡槽①并向上拨动卡扣②，
2. 将滤镜片放入卡槽内③，再松开卡扣完成装配。

4. 滤镜片的使用

遮光罩塑胶罩体可以内嵌一片【4*5.65滤镜片】，遮光斗在不拆斗的情况下也可以从前端安装【圆形螺纹滤镜】。

*如需使用方形镜片叠加：可选购4*5.65滤镜卡槽基础配件(MB-T16-SFH)搭配4*5.65滤镜卡槽叠加配件(MB-T16-SFT)；

使用多片圆形滤镜片叠加：可选购95mm滤镜叠加配件(MB-T16-SCF)

4*5.65方形滤镜片

拉开滤镜卡扣

1



2

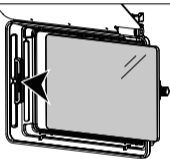

把4*5.65方形滤镜片，按箭头方向装入斗壳上。

3

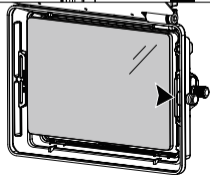

扣好滤镜片完成装配。

方形滤镜取出注意事项：

【注意】：拉开滤镜卡扣取出滤镜片时，需要先用手扶住4*5.65滤镜片，滤镜片会轻微向前弹起，以便取出。此步骤需细心操作，避免滤镜片滑落。

【免责】：如因操作不当使镜片损坏，请自行承担。

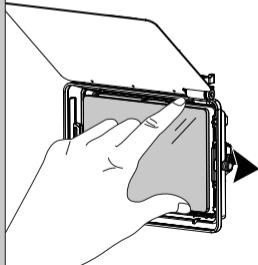

圆形螺纹滤镜片

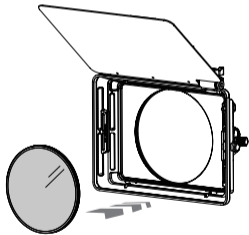

注：圆形螺纹滤镜片不能与95mm可变ND滤镜组同时使用，切勿在安装了圆形螺纹滤镜片后拔插95mm圆形滤镜框，以免对圆形螺纹滤镜片造成损坏。

10

K2套装使用说明(一)

1. 安装95mm可变ND滤镜组

(1) 按照K1步骤安装完后, 插入95mm可变ND滤镜组。

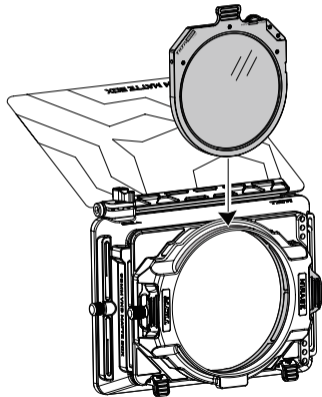

需要取出95mm可变ND滤镜组时, 将安全卡扣拨开, 即可取出。

注: 取出95mm可变ND滤镜组后, 需安装回95mm圆形滤镜框。

(2) 手动控制——95mm可变ND滤镜组右上方有一个齿轮, 用手拨动该齿轮即可改变ND的变量以达到手动控光。

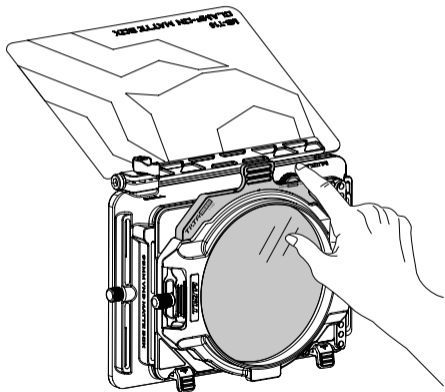

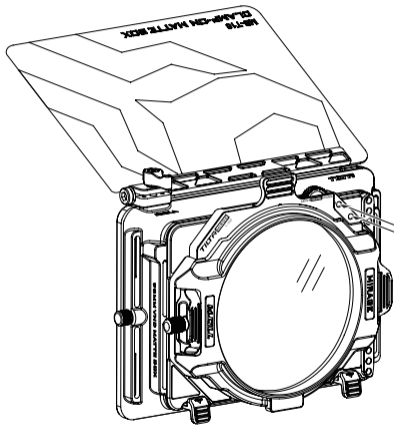

2. 电动控制可变ND

(1) 安装原力N电机适配器①

将原力N电机适配器装配在95mm可变ND滤镜组右上角的两个M3螺丝孔位处，确保适配件的齿轮传动顺畅，再将②原力N马达安装在转接件上，并把齿轮衔接上确保可以传动。

(2) 使用原力N控制手轮/原力M控制手轮/幻境无线控制器配对原力N马达②，都可控制可变ND。

将原力N马达接通电源 [使用前一定要进行行程自检（按下CAL进行自检），自检完成后方可控制ND]。（在稳定器及车拍等移动拍摄时，使用无线控制可变ND，可提高效率和机动性。）

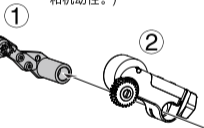

TILTA 幻境无线控制器



TILTA 原力N控制手轮



TILTA 原力M控制手轮

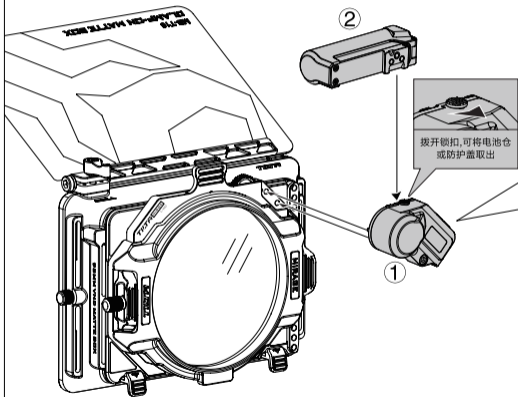

专用马达电动控制可变ND

(1) 安装VND专用马达①

将VND专用马达安装在95mm可变ND滤镜组右上角的两个M3螺丝孔位处即可开机。

(2) 装配14500电池仓②

在使用14500电池仓供电，将其插入VND专用马达上，内装14500电池可为马达供电。

(3) 使用原力N控制手轮/原力M控制手轮/幻境无线控制器④配对马达，都可控制可变ND如前篇一样配对马达，在稳定器及车拍等移动拍摄时，使用无线控制可变ND，可提高效率和机动性。

(4) 使用TILTA 专业跟焦控制手柄可直接通过Type-c接口供电和控制马达



TILTA 幻境无线控制器



TILTA 原力N控制手轮



TILTA 原力M控制手轮

13

认识幻境无线控制器

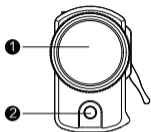

<正面>

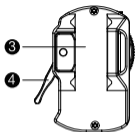

<背面>

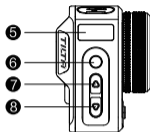

<左侧面>

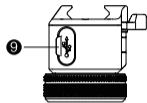

<顶部>

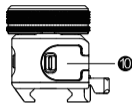

<底部>

① 滚轮

对频后可无线控制马达

② 开关机键

长按:开关机

单击:REC和STBY切换

(在所有菜单里单击可直接返回主界面)

③ NATO滑槽接口

可将控制器安装在带NATO滑条的设备上

④ NATO锁紧扳手

⑤ 显示屏

⑥ CAL键

(1)长按 3 秒自动检测行程

(2)双击可进入手动行程设置

(3)单击可进行 A - B 限位设置

⑦ 向上键

双击:向上翻选择+通道

长按:进入主菜单设置

(包括:无线设置/马达设置/功能设置/系统设置)
在菜单设置里,单击为上选功能,双击为确定功能。

⑧ 向下键

双击:向下翻选择-通道

在菜单设置里,单击为下选功能,双击为退回上一层功能。

⑨ USB-C接口

用于升级固件时使用

⑩ 电池仓口

3.7V 14500 电池

可以不分正负极上电开机

【CAL】键功能说明(一)

[1] 自动CAL功能设置

长按【CAL】键3秒不放,电机进入自动CAL转动(行程检测)。



[2] A-B限位设置



1. 设置A-B限位

[A点]: 转动滚轮到合适的A点后,

单击【CAL】键确认A点。

[B点]: 再转动滚轮到合适的B点后,

单击【CAL】键确认B点。

即A-B限位设置完成。



2. 取消A-B限位

设置完成后再次单击

【CAL】键即可取消。

【CAL】键功能说明(二)

[3] 无限位行程 手动设置说明(此功能, 配合使用原力N/原力M马达)



1. 双击【CAL】键开始手动行程设置, 显示(H_C_A)
2. 调整镜头跟焦距离最近点, 并装上电机, 转动手轮再次调整镜头跟焦圈至无限远(电机跟随转动)。



3. 再次双击【CAL】键手动行程设置成功。

无线设置功能(2.4G 蓝牙)(一)

[1] 2.4G模式是设置无线模块的功率



1. 长按【向上】键进入菜单选项功能, 通过【向上/下】键选中[无线设置(Wireless)选项]并双击【向上】键确定。



2. 进入到 [2.4G模式]后, 双击【向上】键进入到 [2.4G模式(Mode)], 再次双击确定。



3. 通过【向上/下】键选择[高/中/低 (High/Medium /Low)]三个不同档位功率, 选中后双击【向上】键确定即可。

无线设置功能(2.4G 蓝牙)(二)

[2] 蓝牙模式功能



1.长按【向上】键进入菜单选项功能,通过【向上/下】键选中[无线设置(Wireless)]双击【向上】键确定。



2.通过【向上/下】键选中【蓝牙(BLUE)模式】,再双击【向上】键确定。



3.双击[开(ON)]进入连接状态此时蓝牙功能已打开(默认为关闭状态)。



4.进入[连接(Connect)],再次双击【向上】键进入搜索中蓝牙模式连接中...



*可使用手机APP(APP使用后请继续关注TILTA官网资料更新)与蓝牙连接控制跟焦或录制,或者直接连接相机蓝牙(目前能适用BMPCC4K/6K /6K PRO)。

[3] 与BMPCC4K/6K/ 6K PRO相机蓝牙连接并实现录制功能



1.以6K PRO相机为例,打开相机蓝牙功能。



2.在控制器菜单里打开蓝牙功能,调到[连接(Connect)]并双击进入搜索中。

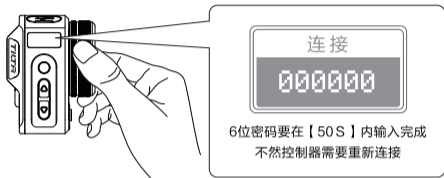

3.连接中相机会弹出一个动态密码，对应地在控制器上输入密码（密码输入说明：6位密码从左到右，用滚轮前后调转到相对应的数字后，双击【向上】键确定，进入第二位数字输入.....输完6位密码后双击【向上】键进入连接）。连接成功后，可以通过控制器上的【开关机】键控制录制(REC和STBY)。

4.连接成功后的相机，（同一台相机）第二次使用时不需要重新输入密码。当控制器要连接另外一台相机时，需要清除蓝牙里的信息，操作方法如下：



①蓝牙菜单里选中【清除】再双击【向上】键。



②相机上的蓝牙菜单上也需点击【清除】，清除完成后，重新去连接操作方法同上。

马达设置功能

[1] 电机方向设置



1. 长按【向上】键进入菜单选项功能，通过【向上/下】键选中[马达设置(Motor)], 双击【向上】键进入到[方向(Direction)].



2. 再次双击进入后, 通过【向上/下】键选择顺时针(CW)或逆时针(CCW) [根据实际情况选择], 选中后双击【向上】键确认完成。

[2] 电机号设置



1. 长按【向上】键进入菜单选项功能，通过【向上/下】键选中[马达设置(Motor)]双击确定，进入后同上一步骤选中[马达号(Number)].



2. 再次双击进入后, 通过【向上/下】键可选择0/1/2/3/4电机号, 选中后双击【向上】键确认完成, 确定后电机号如图所示显示在主界面中。

功能设置

控制器滚轮校准设置



1. 长按【向上】键进入菜单选项功能, 通过【向上/下】键选中[功能设置(Function)], 双击【向上】键进入。



2. 显示[滚轮校准(Wheel Cal)], 此时滚轮往逆时针方向转到最小值, 再往顺时针转到最大值, 双击【向上】键确认校准完成。



[1] 版本信息查看

长按【向上】键进入菜单选项, 通过【向上/下】键选中[系统设置(System)], 双击进入后选中[版本信息(INFO)], 再双击【向上】键确定查看当前固件版本。

系统设置(一)

[2] 语言设置



1. 长按【向上】键进入菜单选项, 通过【向上/下】键选中[系统设置(System)], 双击进入后选中[语言设置(Language)].



2. 双击确定后通过【向上/下】键可选择中文或English, 选中后双击【向上】键确认完成。

系统设置(二)

[3] 一键还原设置



1. 长按【向上】键进入菜单选项功能, 通过【向上/下】键选中[系统设置(System)], 双击进入后选中[一键还原(Restore)].



2. 双击确定后通过【向上/下】键可选择[是]或[否], 选中后双击【向上】键确认一键还原完成。

[4] 显示方向设置



1. 长按【向上】键进入菜单选项功能, 通过【向上/下】键选中[系统设置(System)], 双击进入后选中[显示方向(Disp Flip)].

2. 双击确定后通过【向上/下】键可选择[正常]或[反向]效果, 选中后双击【向上】键确定屏幕方向功能。



屏幕显示[正常]效果

屏幕显示[反向]效果

注: 当屏幕处在[反向]效果时, 通过[一键还原]功能可返回到[正常]效果。

固件升级说明

不装电池的情况下, 同时按住【向上】键和【向下】键再插入Type-C数据线连接到电脑, 将升级文件复制到控制器上, 复制完成后会自动开机升级完成。
升级固件下载可通过TILTA官网对应的产品型号下载

20

认识VND专用马达



<正面>

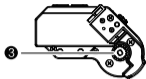

<背面>

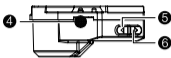

<顶部>

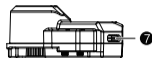

<底部>

- ① 显示屏
- ② M3螺丝
- ③ 0.4M齿轮
- ④ 锁扣
- ⑤ 向上键
- ⑥ 向下键
- ⑦ Type-C接口

用于升级固件及数据拷贝时使用，亦可输入电压供电(电压5-8.4V) 电流要求在2A以上)

▲【向上】键功能说明

通道设置

双击【向上】键为通道减
双击【向下】键为通道加



自动CAL功能设置

方法一：长按【向上】键3S不放，电机进入自动CAL转动(行程检测)。

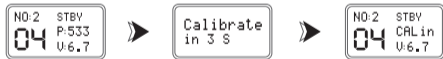

方法二：长按【向上】键进入运行界面，再双击【向上】键确定进入自动CAL转动(行程检测)。



▼【向下】键功能说明

开关机设置

长按【向下】键进入开/关机

电机号设置

3击【向上/下】键进入电机号选择界面，单击【向上】键为马达号减，单击【向下】键为马达号加，不操作时10秒时自动退出(或者3击【向上/下】键退出)。

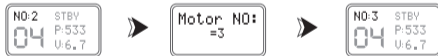

功率说明



可外挂14500电池仓，电机内部电压升到6.8V左右，Type-C接口同时也输出6.8V电压。

Type-C输入电压适用5V到8.4V供电使用，电流要求在2A以上。



空载电流：100MA电流内左右

负载电流（滤镜片）：600MA电流内左右



95mm圆形滤镜框
[用于装配95mm滤镜片]



95mm可变ND滤镜组
[双层滤镜片,可手动调节ND值]



95mmCPL偏振滤镜
[单层滤镜片,消除或减弱非金属表面的反光]



95mm双面滤镜框
[可装配双片95mm滤镜片]



可变ND轻便型卡圈
[直接装配95mm镜头或可装配带其他尺寸接圈的镜头]



80mm无螺纹镜头接圈
[用于无螺纹的80mm镜头]



86/85/82/77/72/67/62/58/55/52mm
镜头接圈
[装配86/85/82/77/72/67/62/58/55/52mm镜头]



14500电池充电器
[用于给14500电池供电]



幻境无线控制器
[用于无线控制ND变量,在稳定器及车拍等移动拍摄时提高效率 and 机动性]



VND专用马达
[电动控制可变ND]



原力N电机适配器
[用于装配原力N马达]



14500电池仓
[用于安装14500电池]



无线信号放大器
[用于远距离拍摄(如航拍)]



15mm导轨支撑
[用于适配15mm导轨系统]



4*5.65滤镜卡槽
叠加配件
[用于装配4*5.65镜片]



4*5.65滤镜卡槽
基础配件
[用于装配4*5.65滤镜卡槽
叠加配件]



95mm滤镜叠加配件
[用于多片镜片叠加时使用]



幻境软胶消光斗
[用于消除玻璃反光]



①保护镜安装固定配件
②保护镜
[高速拍摄时保护镜头和滤镜组]



滤镜包
[用于收纳和保护滤镜片]



多功能套装机
[用于收纳和保护遮光斗]

Thank you for choosing Tilita products. This content has been created in regards to your safety, responsibilities, and legal rights as the customer. Please carefully read the text prior to using the product to ensure that you fully understand the correct procedures and safety precautions before use. Tilita technology CO., Ltd.reserves the right to final interpretation of this content and other related information. Potential updates to the product may occur without prior notice.Please visit www.tilita.com for the latest product information.

Please do not carry out any unauthorized repair to Hydra Alien Car Mounting System or change its mechanical structures.Any unauthorized operation may cause damage to the product. Tilita technology Co., Ltd will not take responsibility for any damage that was caused by unauthorized operation.

By using this product, you will be regarded as understanding this disclaimer as well as accepting of all policies and regulations put forth by Tilita technology Co., Ltd.

Tilita is a registered trademark that belongs to Tilita technology Co., Ltd and its subsidiary company. All product and brand names that are mentioned in this content belong to Tilita technology Co., Ltd and its subsidiary company.

Disclaimers and essential information to know before using the VND filter products:

- *Notes:** The VND's adjustment range is ND 0.3–2.7. We advise using lenses that have a focal length longer than 35mm. Using the VND at higher density on lenses wider than 24mm will have a vignetting effect. (This cannot be avoided due to the variable ND filter's structure and mechanism.) Please be aware of this before making your purchase.
- *Notes on 4x5.65 filters:** Please refer to Page 9 of this user manual for instructions on handling 4x5.65 filters. Please follow instructions to avoid any mishandling of the product.
- *Disclaimers:** Tilta is not responsible for any broken filters, vignetting, and/or unusable photo or video footage caused by mishandling of the product.

Filter products maintenance

Optical products are precision instruments which requires protective packing during transportation and storing. Keep the filter products in a dry and cool area. Stay away from water, moisture, and dust. Possible artificial damages include:

- ① Falling, collision, and scratches during handling.
- ② Improper storing can cause erosion and mold on filter.
- ③ Scratches caused by filter stains and improper cleaning.
- ④ Damage caused by improper transportation.
- ⑤ Scratches and paint chips caused by handling and contact.
- ⑥ Scratches caused by mishandling during packing, unclean or dusty environment, improper cleaning. (Use an air blower to clean up the dust on the filter surface. For any remaining dust or stains, use a lens cleaning wipe with 97% alcohol and wipe the filter in circles. Avoid any secondary damage from the dust.)
- ⑦ If sea transportation occurs, seal the product and store it in a dry environment. Keep it away from salty air or water.

Damage caused by any of the above mishandling of the product and/or any other unforeseen behaviors are not included in the product's service and warranty. For non-user error related product quality issues, Tilta guarantees exchange and service within 3 months of the purchase.

When shooting in high speed moving conditions or extreme weather (such as desert, snow, etc), we highly recommend using [Filter Protector Kit] to protect your lens and filter.

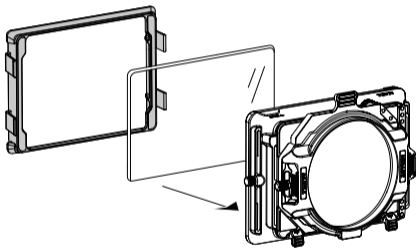

*The top flag(MB-T16-TF) can be removed if shooting under high speed moving conditions.

When removing the matte box and its additional gear (such as the flare-free matte box, additional 95mm circular filter tray, and 4X5.65 filter tray backing), please keep the additional piece within 15° of your setup, and slide the additional piece upwards to avoid any damage to the locking toggle on the matte box body.

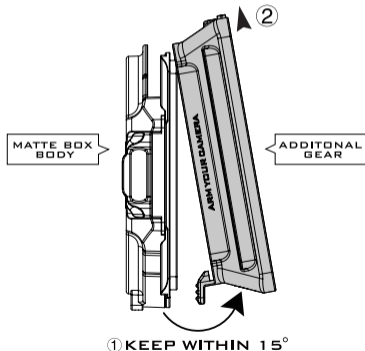

25 TILTA MIRAGE MATTE BOX

① CARBON FIBER
TOP FLAG

②



4X5.65 MATTE BOX BODY

The front hood of the matte box body has aerodynamic design which minimizes the wind drag and the impact on the camera stabilizer during car shoots and aerial shoots.

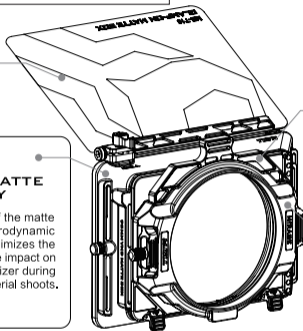

③



CIRCULAR FILTER TRAY
FOR TILTA MIRAGE
[Filter not included]



95MM VARIABLE ND
FOR TILTA MIRAGE
[Variable ND filter included]

④

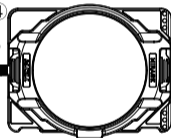

VND FILTER HOLDER

Ultra lightweight material.
Ergonomic design.
Quick release locking toggle.
Multifunctional design.

[Tilta Mirage Matte Box] is a matte box that fully satisfies the needs and wants of content creators. The Tilta Mirage adopts a lightweight and modular design. The circular 95mm insert filter tray provides users with the possibility of using lighter weight and lower cost filters. In addition, we have introduced the wireless VND module which can pair with the matte box in order to support your production needs.

26 OVERVIEW

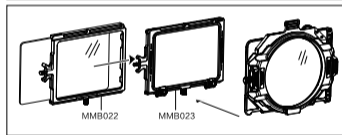
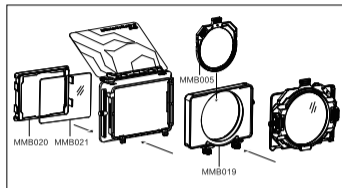
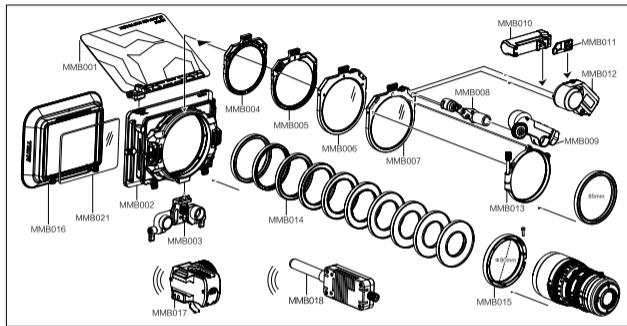

NO.	PRODUCT NAME	SKU
MMB001	Top Flag for Tilt-a-Mirage	MB-T16-TF
MMB002	VND Filter Holder	-----
MMB003	15mm LWS Support for Tilt-a-Mirage	MB-T16-LS
MMB004	Circular Filter Tray for Tilt-a-Mirage	MB-T16-CFT
MMB005	Dual Circular Filter Tray for Tilt-a-Mirage	MB-T16-DCF
MMB006	95mm Polarizer Filter for Tilt-a-Mirage	MB-T16-POLA

NO.	PRODUCT NAME	SKU
MMB007	95mm Variable ND for Tilt-a-Mirage	MB-T16-VND
MMB008	Nucleus Nano Motor Adapter for Tilt-a-Mirage	MB-TM-NMA
MMB009	Nucleus Nano Motor	WLC-T04
MMB010	14500 Power Supply for Tilt-a-Mirage Motor	MB-TM-PS
MMB011	Motor Cover	-----
MMB012	Wireless Motor for Tilt-a-Mirage	MB-TM-WM

NO.	PRODUCT NAME	SKU
MMB013	Lightweight Filter Clamp-On Adapter	MB-T16-LFA
MMB014	95/85/82/77/72/67/62/58/55/52mm Adapter Ring	-----
MMB015	80mm Cinema Adapter Ring for Tilt-a-Mirage	MB-T16-C80
MMB016	Rubber Hood for Tilt-a-Mirage	MB-T16-RH
MMB017	Wireless Controller for Tilt-a-Mirage	MB-TM-WC
MMB018	Range Extender for Tilt-a-Mirage	-----

NO.	PRODUCT NAME	SKU
MMB019	95mm Stackable Circular Filter Tray for Tilt-a-Mirage	MB-T16-SCF
MMB020	Filter Protector Frame for Tilt-a-Mirage	MB-T16-FPF
MMB021	Filter Protector Glass for Tilt-a-Mirage	MB-T16-FPG
MMB022	4x5.65 Stackable Filter Tray for Tilt-a-Mirage	MB-T16-SFT
MMB023	4x5.65 Stackable Filter Tray Holder for Tilt-a-Mirage	MB-T16-SFH

KIT A



① Top Flag for Tiltla Mirage



② Tiltla Mirage Matte Box Body



③ Circular Filter Tray for Tiltla Mirage



④ 82/77/72/67mm Adapter Ring



⑤ Basic Soft Carrying Case

KIT B



① Top Flag for Tiltla Mirage



② Tiltla Mirage Matte Box Body



③ Circular Filter Tray for Tiltla Mirage



④ 95mm Variable ND for Tiltla Mirage



⑤ 82/77/72/67mm Adapter Ring



⑥ 15mm LWS Support for Tiltla Mirage



⑦ Nucleus Nano Motor Adapter for Tiltla Mirage



⑧ Filter Pouch



⑨ Advanced Soft Carrying Case for Tiltla Mirage

KIT C



① Top Flag for Tiltla Mirage



② Tiltla Mirage Matte Box Body



③ Circular Filter Tray for Tiltla Mirage



④ 95mm Variable ND for Tiltla Mirage



⑤ 82/77/72/67mm Adapter Ring



⑥ 15mm LWS Support for Tiltla Mirage



⑦ 14500 Battery Charger



⑧ Filter Pouch



⑨ Advanced Soft Carrying Case for Tiltla Mirage



⑩ Wireless Motor for Tiltla Mirage



⑪ Motor Cover



⑫ 14500 Power Supply for Tiltla Mirage Motor



⑬ Wireless Controller for Tiltla Mirage



⑭ 18mm NATO Rail Attachment

1. Mounting the matte box

(1) Select the adapter ring that fits the front diameter of your lens. (67mm, 72mm, 77mm, and 82mm adapter rings are included in the kit.)

(2) If you are looking for other adapter ring sizes, please contact our customer service.

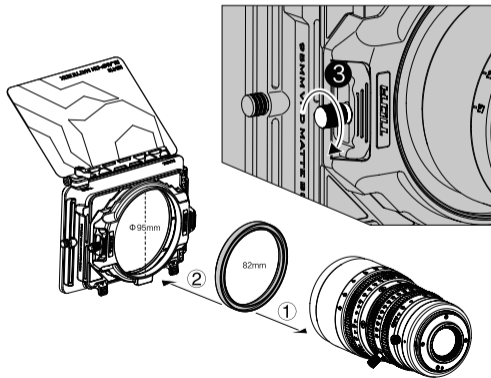

(3) If the front diameter of your lens is 95mm, no adapter ring is needed. Loosen the tie down screw on the right side of the matte box. Place the matte box onto the front of the lens. Adjust the level and tighten the tie down screw.

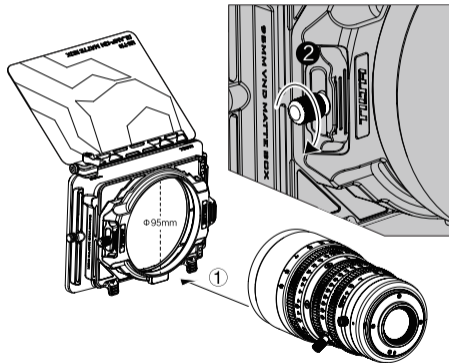

2. Mounting the carbon fiber top flag

- (1) The top flag and the tie down screw stay as one piece.
- (2) The matte box is not needed when there is no lens flare. Adjust the tie down screw to adjust the top flag's angle.

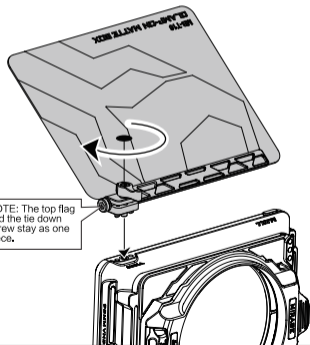

3. Mounting the 95mm circular filter tray and filter

- (1) Kit A comes with a 95mm circular filter tray. Follow the picture below, pull (4) the locking clip to take out (5) the 95mm circular filter tray.
- (2) The filter slot is compatible with major brands of 95mm circular filters, such as ND filters, streak filters, star filters, pro-mist, black pro-mist, etc.
- (3) The 95mm circular filter weighs only 1/4 of a traditional 4 x 5.65 filter. Compared to the traditional threaded filter, the circular insert filter is more efficient and practical for shooting.

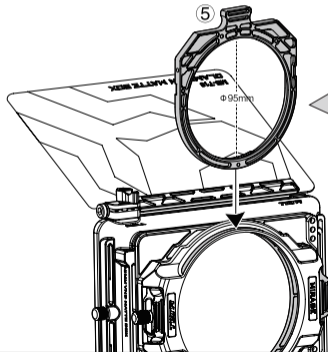

Installing the 95mm Circular Filter

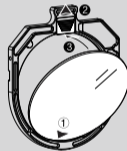

1. Place the filter into (1) the bottom of the filter tray and pull up (2) the locking toggle.
2. Place the filter into (3) the filter tray, Release the locking toggle.

- (4) Pull the locking toggle to release the circular filter tray

4. Installing the filter

4x5.65 filter can be mounted onto the matte box body. The circular threaded filter can be installed from the front without dismantling the matte box.

*If you would like to double up the filter, please purchase the 4x 5.65 filter tray (MB-T16-SFH) backing and the additional 4x 5.65 filter tray (MB-T16-SFT).

To double up the circular filter, please purchase the additional 95mm circular filter tray (MB-T16-SCF).

4X5.65 Filter

Release the locking toggle

1



2

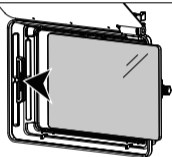

Slide the 4X5,65 filter into the matte box as shown above.

3

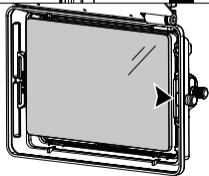

Mount the filter into position.

Notes on handling the 4x5.65 filters:

NOTE: When releasing the filter locking toggle, use one hand to hold onto the 4x5.65 filter. The filter releases forward. Please use extra caution when operating to avoid any filter damage.

DISCLAIMERS: Tilta is not responsible for any user error-caused broken filters.

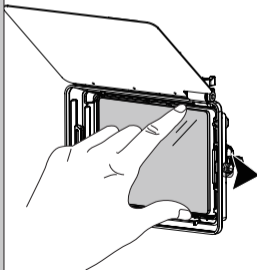

Circular Threaded Filter

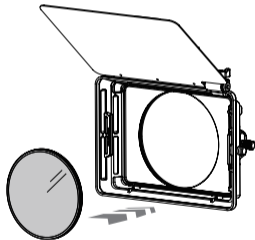

NOTE: The circular threaded filter CANNOT be used with the 95mm variable ND filter at the same time. Please do not insert the 95mm circular filter tray after mounting the circular threaded filter.

31 KIT B INSTRUCTIONS (PART I.)

1. Mounting the 95mm variable ND

(1) After completing the kit A instructions steps, insert the 95mm variable ND.

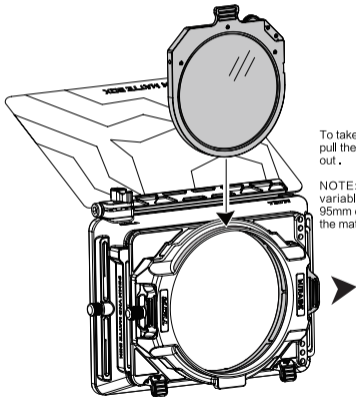

To take out the 95mm variable ND, pull the locking toggle, then take it out.

NOTE: After taking out 95mm variable ND, please place the 95mm circular filter tray back into the matte box.

(2) Manual control—To control the ND manually, toggle the wheel in the top right corner of the variable ND filter tray.

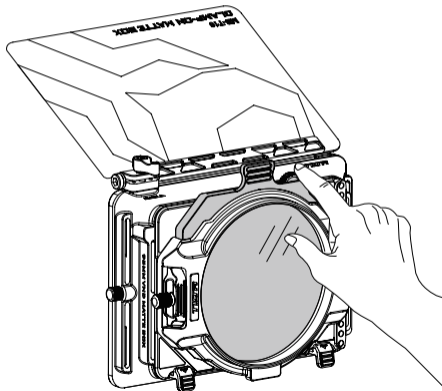

32 KIT B INSTRUCTIONS (PART II.)

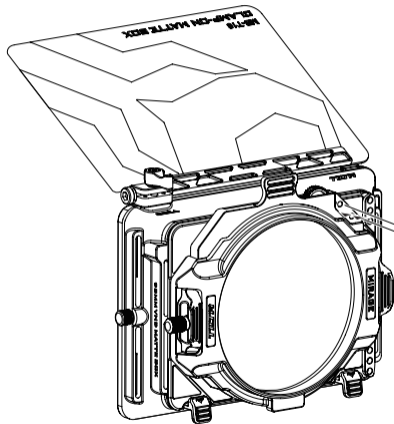

2. Electronic control

(1) Installing the ① Nucleus Nano motor adapter for Tilta Mirage.

Align the M3 screws on the Nucleus Nano motor adapter with the M3 screw holes on the 95mm variable ND. Make sure the wheel can rotate smoothly. Mount the Nucleus Nano motor onto the motor adapter, align the wheels and make sure they can rotate smoothly.

(2) Controlling the variable ND via Nucleus Nano hand wheel controller & Nucleus M hand unit & wireless controller for Tilta Mirage.

Connect ② the Nucleus Nano motor to power. Press and hold the CAL button to calibrate. You will be able to control the ND filter after the calibration is complete. [While operating moving shots (handheld, gimbal, car mount, etc), controlling the variable ND wirelessly will improve efficiency.]

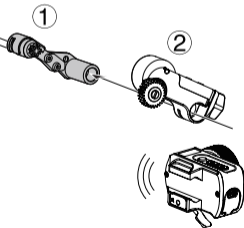

Wireless Controller
for Tilta Mirage

for Tilta Mirage Wheel
Controller

Nucleus M Hand Unit

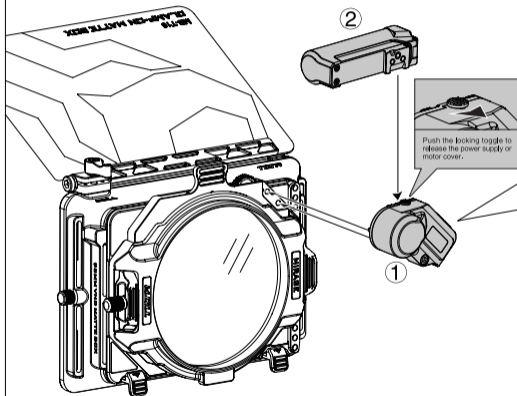

Controlling the variable ND via wireless motor for Tilta Mirage

(1) Installing ① the wireless motor for Tilta Mirage.

Align the M3 screws on the wireless motor adapter with the M3 screw holes on the variable ND. Turn on the motor.

(2) Installing ② the 14500 power supply for Tilta Mirage motor.

To use the 14500 power supply, slide the battery chamber onto the motor.

(3) Controlling the variable ND via Nucleus Nano hand wheel controller & Nucleus M hand unit & ④ wireless controller for Tilta Mirage.

Please refer to the previous page for pairing instructions. While operating moving shots (handheld, gimbal, car mount, etc), controlling the variable ND wirelessly will improve efficiency.

(4) To control via the Tilta advanced focus handle, connect the handle and the motor via the USB-C ports.

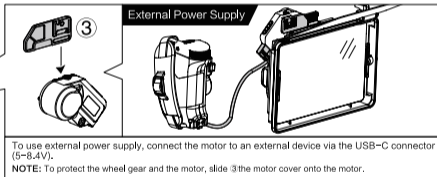

Wireless Controller
for Tilta Mirage



Nucleus Nano Hand
Wheel Controller



Nucleus M Hand Unit

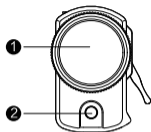

<FRONT>

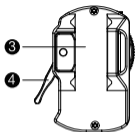

<BACK>

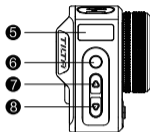

<LEFT>

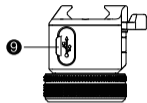

<TOP>

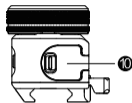

<BOTTOM>

1 Hand wheel

For controlling the wireless motor.

2 Power button

Long hold: power on and off.
Single click: Run/stop.
(Under any menu settings, single click the power button to return to the main menu.)

3 NATO rail port

The wireless controller can be mounted on setups with a NATO rail.

4 NATO rail tie down**5 Display****6 CAL key**

(1) Hold for 3s to activate automatic calibration.
(2) Double click to activate manual calibration.
(3) Single click to set A-B marks.

7 Up key

Double click: Go up in selection + raise channel.
Long hold: Enter main menu (including wireless setting, motor setting, function setting, system setting).
In menu, single click to go up, double click to confirm.

8 Down key

Double click: Go down in selection + lower channel.
In menu, single click to go down, double click to return to the previous menu.

9 USB-C port

For firmware update.

10 Battery chamber

For 14500 battery (3.7V). The battery can be installed in either direction regarding positive and negative.

CAL Key Functions (Part I.)**[1] Auto CAL Setting**

Long hold CAL key for 3 seconds, the motor will enter auto CAL and spin.

**[2] A-B marks setting****1.Set A-B marks**

A mark: Rotate the hand wheel to the desired position for A mark. Single click "CAL" key to confirm.
B mark: Rotate the hand wheel to the desired position for B mark. Single click "CAL" key to confirm.
A-B marks are now set.

**2.Cancel A-B marks**

After AB marks are set, single click CAL key again to cancel them.

35 WIRELESS CONTROLLER FUNCTIONS (PART I.)

CAL Key Functions (Part II.)

[3] Free Rotation. Manual Calibration Instructions.

(This function is compatible with Nucleus M and Nucleus Nano motors.)



1. Double click CAL key to initiate manual CAL setting. Display shows as (H_C_A).

2. Manually rotate the lens focus to close focus, and install the motor to the lens. Then rotate the hand wheel so that the lens is at infinite focus.



3. Double click CAL key again to confirm the free rotation setup.

Wireless Settings (2.4G bluetooth) (Part I.)

[1] 2.4G mode is for wireless frequency setting



1. Long hold "Up" key to enter menu settings. Use "Up" and "Down" keys to toggle through and select Wireless setting. Double click "Up" key to confirm selection.



2. Double click "Up" key to enter [2.4G mode].



3. Use "Up" and "Down" keys to toggle through and select High / Medium / Low frequency. Double click "Up" key to confirm the selection.

36 WIRELESS CONTROLLER FUNCTIONS (PART II.)

Wireless Settings (2.4G bluetooth) (Part II.)

[2] Bluetooth mode functions



1. Long hold "Up" key to enter menu settings. Use "Up" and "Down" keys to toggle through and select Wireless setting. Double click "Up" key to confirm selection.



2. Use "Up" and "Down" keys to toggle through and select BLUE. Double click "Up" key to confirm selection.



3. Double click ON to enter connection mode. (The bluetooth is turned off by default.)



4. After entering "Connect", double click "Up" key to enter "Search" mode.

*Use phone APP to connect the Bluetooth devices for lens control or camera run/stop control. Or connect the devices directly via Bluetooth. (As of right now, only applicable to BMPCC 4K/6K PRO.) (After downloading the APP, please follow the updates from Tilta official website.)

[3] Connecting with BMPCC 4K/6K PRO via Bluetooth for Run/Stop Control



1. Take BMPCC 6K PRO camera as an example. Open camera menu and find bluetooth setting.



2. Navigate to Bluetooth setting on the wireless controller, select Connect and double click the Up key to enter searching mode.

37 WIRELESS CONTROLLER FUNCTIONS (PART III.)

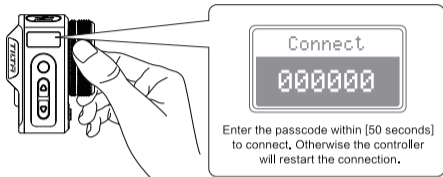
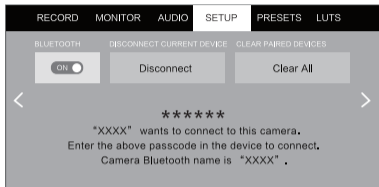

3. During connection, a passcode will be generated from the camera. Enter the passcode on the wireless controller.
[Passcode instructions: The passcode contains 6 digits. Use the hand wheel to move between digits, double click "Up" key to confirm and enter the next digit. Enter all 6 digits, then double click "Up" key to connect.]
Once the connection is complete, use the power button on the controller to control REC/STBY.

4. Once the first connection of the device is complete, no passcode will be needed to connect in the future. To use the control with other cameras, clear the bluetooth info. Please see instructions below.



- ① In the Bluetooth setting, select Clear and double click "Up" key to confirm.



- ② Clear the Bluetooth info on the camera by selecting Clear All.

Motor Setting

[1] Motor direction



1. Long hold “Up” key to enter menu settings. Use “Up” and “Down” keys to toggle through and select Motor. Double click “Up” key to confirm and enter Direction menu.



2. Double click “Up” key in Direction “Down” keys to toggle through and select CW or CCW. Then double click “Up” key to confirm the selection.

[2] Motor number



1. Long hold “Up” key to enter menu settings. Use “Up” and “Down” keys to toggle through and select Motor. Double click “Up” key to confirm and enter Number menu.



2. Double click “Up” key in Number. Use “Up” and “Down” keys to toggle through and select a motor number (0/1/2/3/4). Then double click “Up” key to confirm the selection. The selected motor number will appear on the display.

39 WIRELESS CONTROLLER FUNCTIONS (PART V.)

Function Setting

Calibrating the hand wheel



1. Long hold "Up" key to enter menu settings. Use "Up" and "Down" keys to toggle through and select Function. Double click "Up" key to confirm.



2. When the display shows Wheel Cal, rotate the hand wheel counterclockwise to the minimum end, then rotate the hand wheel to the maximum end. Double click "Up" key to confirm.

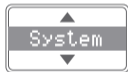

[1] Looking up the version info

Long hold "Up" key to enter menu settings. Use "Up" and "Down" keys to toggle through and select System. Double click "Up" key to enter Info, and double click "Up" key again to look up the current firmware info.

System Setting (Part I.)

[2] Language Setting

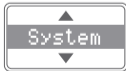

1. Long hold "Up" key to enter menu settings. Use "Up" and "Down" keys to toggle through and select System. Double click "Up" key to confirm and select Language.



2. Double click "Up" key in Language "Down" keys to toggle through and select 中文 or English. Then double click "Up" key to confirm the selection.

40 WIRELESS CONTROLLER FUNCTIONS (PART VI.)

System Setting (Part VI.)

[3] Restore Setting



1. Long hold "Up" key to enter menu settings. Use "Up" and "Down" keys to toggle through and select System. Double click "Up" key to confirm and select Restore.



2. Double click "Up" key in Restore "Down" keys to toggle through YES or NO. Then double click "Up" key to confirm the selection.

[4] Display Directions Setting



1. Long hold "Up" key to enter menu settings. Use "Up" and "Down" keys to toggle through and select System. Toggle through and double click "Up" key to select Display.



2. Use "UP" and "Down" keys to toggle through and double click "Up" key to select Normal or Inverted.



Normal or Inverted

Inverted display

NOTE: When the display is in inverted direction, use "Reset" function to return to normal direction.

Firmware Updates

When the battery is not installed, long hold both "Up" and "Down" keys at the same time, and connect the wireless controller to a computer via a USB-C cable. Copy the firmware file to the wireless controller. After the copying is complete, the wireless controller will automatically turn on and complete the firmware update. Please visit the Tilta official website to download firmwares for the products accordingly.

41 WIRELESS MOTOR FOR TILTA MIRAGE OVERVIEW



<FRONT>

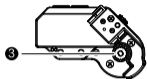

<BACK>

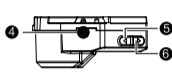

<TOP>

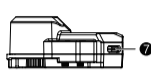

<BOTTOM>

- 1 Display
- 2 M3 screw
- 3 0.4M gear
- 4 Locking toggle
- 5 Up key
- 6 Down key
- 7 USB-C port

Used for firmware update, data backup, and input power supply (input 5~8.4V, 2A+)

Up Key Functions

Channel settings

Double click the Up Key to lower channel
Double click the Down Key to raise channel

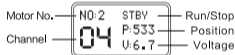

Auto CAL settings

Method 1: Long hold the Up Key for 3 seconds, the motor will enter auto CAL and spin.

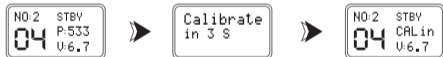

Method 2: Long hold the Up Key to enter the running interface, then double click Up Key to enter auto CAL spin.

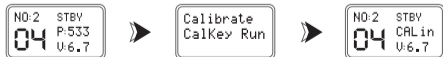

Down Key Functions

On/Off setting

Long hold Down key to enter on/off setting.

Motor No. setting

Triple click the Up or Down Key to enter the motor No. interface, Single click the Up Key to lower the motor No., and single click the Down Key to raise the motor No..If no action is executed in 10 seconds, the interface will exit automatically. (Or triple click the Up or Down Key to exit the interface.)

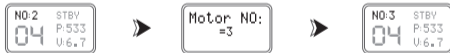

Notes on Power



The motor can be powered by the external 14500 power supply for Tilta Mirage motor. When the motor's voltage is around 6.8V, the USB-C port can output 6.8V power.

The USB-C port can input 5~8.4V, 2A.



No-load current: Around 100 mA.
Load current (with the VND filter): Around 600 mA.



Circular Filter Tray for Tilta Mirage

[For holding 95mm circular filters.]



95mm Variable ND for Tilta Mirage

[Dual filters. Supports manual ND adjustment.]



95mm Polarizer Filter for Tilta Mirage

[Single filter. Eliminates or reduces glare.]



Dual Circular Filter Tray for Tilta Mirage

[For holding two circular filters.]



Lightweight Filter Clamp-on Adapter

[Mounts directly onto 95mm diameter lenses or other sizes diameter lenses or other sizes]



80mm Cinema Adapter Ring for Tilta Mirage

[For mounting onto 80mm front diameter lenses.]



86/85/82/77/72/67/62/58/55/52mm Adapter Ring

[For mounting onto 86/85/82/77/72/67/62/58/55/52mm front diameter lenses.]



14500 Battery Charger

[For charging 14500 batteries.]



Wireless Controller for Tilta Mirage

[Controls ND wirelessly during gimbal, car shoots, etc]



Wireless Motor for Tilta Mirage

[Electronic control for ND.]



14500 Power Supply for Tilta Mirage Motor

[Battery chamber for 14500 battery.]



14500 Power Supply for Tilta Mirage Motor

[Battery chamber for 14500 battery.]



Range Extender for Tilta Mirage

[For remote control during long distance shoots, such as drone shoot.]



15mm LWS Support for Tilta Mirage

[For mounting 15mm rods.]



4x5.65 Stackable Filter Tray for Tilta Mirage

[For holding a 4X5.65 Filter.]



4x5.65 Stackable Filter Tray Holder for Tilta Mirage

[For mounting an additional 4X5.65 Filter Tray.]



95mm Stackable Circular Filter Tray for Tilta Mirage

[Holds additional circular filter.]



Rubber Hood for Tilta Mirage

[Eliminate glass flare]



① Filter Protector Frame for Tilta Mirage
② Filter Protector Glass for Tilta Mirage

[Protector for lenses and filters during high speed moving conditions.]



Filter Pouch

[Organizer for the filters]



Advanced Soft Carrying Case for Tilta Mirage

[Organizer for the matte box.]

MIRAGE MOTORIZED VND MATTE BOX